

# **Interconnection Feasibility Study Report**

## **GIP-IR623-FEAS-R2**

**Generator Interconnection Request IR623**  
**100 MW Wind Generating Facility**  
**Location Higgins Mountain, Cumberland County, NS**

2022-04-08

Control Centre Operations  
Nova Scotia Power Inc.

### Executive Summary

The Interconnection Customer (IC) submitted an Interconnection Request (IR623) for Network Resource Interconnection Service (NRIS) for a proposed 100 MW wind generation facility interconnected to NSPI transmission system, with a Commercial Operation Date of March 31, 2024. The Point of Interconnection (POI) requested by the customer is line L-6613, a 138 kV transmission line between 1N-Onslow substation and 74N-Springhill substation in NS with a load tapped off at 81N-Debert substation. The generation will consist of twenty-seven wind turbines.

This feasibility assessment is conducted with IR623 generation to be used in NS and not for exporting outside NS and to displace the planned phased out coal generation in Cape Breton as per NSPI's generation plan. If IR623 were to displace non-coal generation in Halifax, then major system upgrades associated with increasing Onslow South corridor and Metro Dynamic Reactive Reserve could be required and are not accounted for in this feasibility assessment.

Based on the information provided by IC, this feasibility assessment provides the following findings:

- The Point of Interconnection (POI) will be on L-6613 at approximately 30 km from 1N-Onslow substation
- The new 138 kV spur line, from the IC's 138 kV to 34.5 kV substation to POI, will be approximately 3.51 km in length. The IC will be responsible for obtaining the Rights of Way for this spur line.
- IR623 NRIS of 100 MW output does not violate thermal or voltage criteria when displacing planned phased out coal generation in Cape Breton and not generation in Halifax, NS.
- Unrelated to any system issue, regarding the two 138 kV to 34.5 kV, 30/40/50 MVA transformers for the interconnection of IR623 to L-6613, it is noted that IR623 can generate up to 100MW and provide up to +/- 50.1 MVAR, for a total of 112 MVA. Even with power losses in the individual wind turbine transformers, the collector circuits, and the two 138 kV to 34.5 kV transformers, the loading on these two transformers can exceed 100 MVA under some system conditions. It is recommended that the IC will re-assess the size of these transformers.
- IR623 voltage flicker and harmonic levels will be studied in System Impact Study (SIS) as the information was not provided at the time of this feasibility assessment.
- IR623 does not meet NSPI's power factor requirement when it delivers reactive power to the power system. The IC will explore the options to mitigate.
- The estimated short circuit ratio (SCR) for IR623 at the 34.5 kV bus at minimum system generation with L-6613 section from Onslow to Debert or from Debert to POI is out of service is 2.41, less than the minimum of 2.5 for these wind turbines. It is recommended that the IC should discuss with the wind turbine supplier for low SCR options.

- The estimated loss factor for IR623 is 9.3% at 100 MW output.
- The high-level cost estimate, in 2022 Canadian dollars, for IR623 interconnection to L-6613 is \$9,597,500 which includes 10% contingency and excludes HST. The cost estimate includes a new 138 kV three breaker ring bus substation at the POI and the IC will be responsible for obtaining the land and access for this new substation.
- This feasibility assessment is completed without accounting for TSR411 which could significantly alter the results of this assessment.

IR623 will be required to meet NSPI's Generator Interconnection Procedure (GIP) and Transmission System Interconnection Requirements (TSIR).

This feasibility assessment will be further subjected to the subsequent SIS and Facility Study which will determine the final system requirements, upgrades, and cost estimate for IR623.

## Table of Contents

Executive Summary .....	ii
Table of Contents .....	iv
1.0 Introduction .....	1
2.0 Scope.....	3
3.0 Assumptions.....	4
3.1 System Assumptions .....	4
3.2 Project Assumptions.....	5
4.0 Projects with Higher Queue Positions.....	6
5.0 Short-Circuit Duty / Short Circuit Ratio .....	8
6.0 Voltage Flicker and Harmonics.....	9
7.0 Thermal Limits.....	9
7.1 NS Load Forecast.....	9
7.2 IR623 Model.....	9
7.3 IR623 Steady State Analysis Result.....	10
8.0 Voltage Limits.....	14
9.0 System Security / Bulk Power Analysis.....	15
10.0 Loss Factor .....	15
11.0 Expected Facilities Required for Interconnection .....	16
12.0 Facilities and Network Upgrades Cost Estimate.....	17
13.0 Preliminary Scope of the SIS .....	18

## List of Tables

Table 1: L-6613 ratings .....	5
Table 2: Maximum generation short circuit level system normal .....	8
Table 3: Minimum generation short circuit level system normal .....	8
Table 4: Minimum generation short circuit level with 67N-T71 Out.....	9
Table 5: Power system cases.....	11
Table 6: Contingencies in NS and NB studied.....	13
Table 7: Power factor with Qmax .....	14
Table 8: Power factor with Qmin.....	15
Table 9: Loss factor .....	16

Table 10: Cost estimates.....18

**List of Figures**

Figure 1: IR623 physical location.....2  
Figure 2: IR623 POI electrically (not to scale) .....3  
Figure 3: GIP Queue.....6  
Figure 4: TSR Queue.....7  
Figure 5 Power Factor with Qmax .....14  
Figure 6 Power Factor with Qmin .....14

## 1.0 Introduction

The Interconnection Customer (IC) submitted an Interconnection Request (IR623) for Network Resource Interconnection Service (NRIS) for a proposed 100 MW wind generation facility interconnected to NSPI transmission system, with a Commercial Operation Date of March 31, 2024. The Point of Interconnection (POI) requested by the customer is line L-6613, a 138 kV transmission line between 1N-Onslow substation and 74N-Springhill substation in NS with a load tapped off at 81N-Debert substation. The generation will consist of twenty-seven wind turbines.

The following information is collected from the document, Interconnection Request Appendix 1 to GIP, signed by the IC on August 17, 2021 and by NSPI on September 2, 2021:

- Service NRIS
- Capacity 100 MW, comprising of 27 wind turbines
- Location Higgins Mountain, NS
- Individual wind turbine rating:
  - 4.256 MVA, 690 V
  - Power Factor: PF option +/- 1.855 MVAR at Full Output
  - Short Circuit Ratio > 2.5
  - Maximum output 3.83 MW
- Substation step-up transformers:
  - 2 x 25/42 MVA, Positive impedance Z1 of 8.33% on 25 MVA and X/R of 20.
  - 138 kV/34.5 kV plus Tertiary at 12.47 kV
  - Winding HV Wye, LV Delta, Tertiary Delta
- Electrical one-line showing:
  - Wind turbines: GE 3.8-130, 690V, 3.83 MW, +/- 0.9 PF
  - The substation step-up transformers
    - Two 30/40/50 MVA, Z=8.33%
    - 138 kV/34.5 kV plus Tertiary at 12.47 kV
    - Winding HV Wye, LV Delta, Tertiary Delta
  - Four collector circuits
  - Individual 34.5 kV to 690V transformers:
    - 4.5 MVA, 35.4 kV to 690V, +/-2.5% taps
    - Z = 5.75%
  - POI at 30 km radially on L-6513 from 1N-Onslow substation
  - The IC 138kV/34.5kV substation is 3.51 km from L-6513 connection
  - The conductors for the 138kV spur line are Drake, 795ACSR
  - The Point of Common Coupling is at 138 kV bus at 1N-Onslow substation

As the information regarding the substation step-up 138kV/34.5kV transformers are not consistent. The form shows two 25/42 MVA transformers whereas the electrical one-line

shows two 30/40/50 MVA transformers, the values as indicated on the electrical one-line will be used in this feasibility assessment.

Also, the electrical one-line and the Interconnection Request Appendix 1 to GIP show the proposed POI being at the intersection of L-6513, but the feasibility request is for POI to be on L-6613. Following a meeting with the IC and subsequent correspondence, the IC has selected to have this feasibility study completed based on the POI being on L-6613.

Figure 1 shows IR623 physical location and Figure 2 shows electrical connection and the POI.

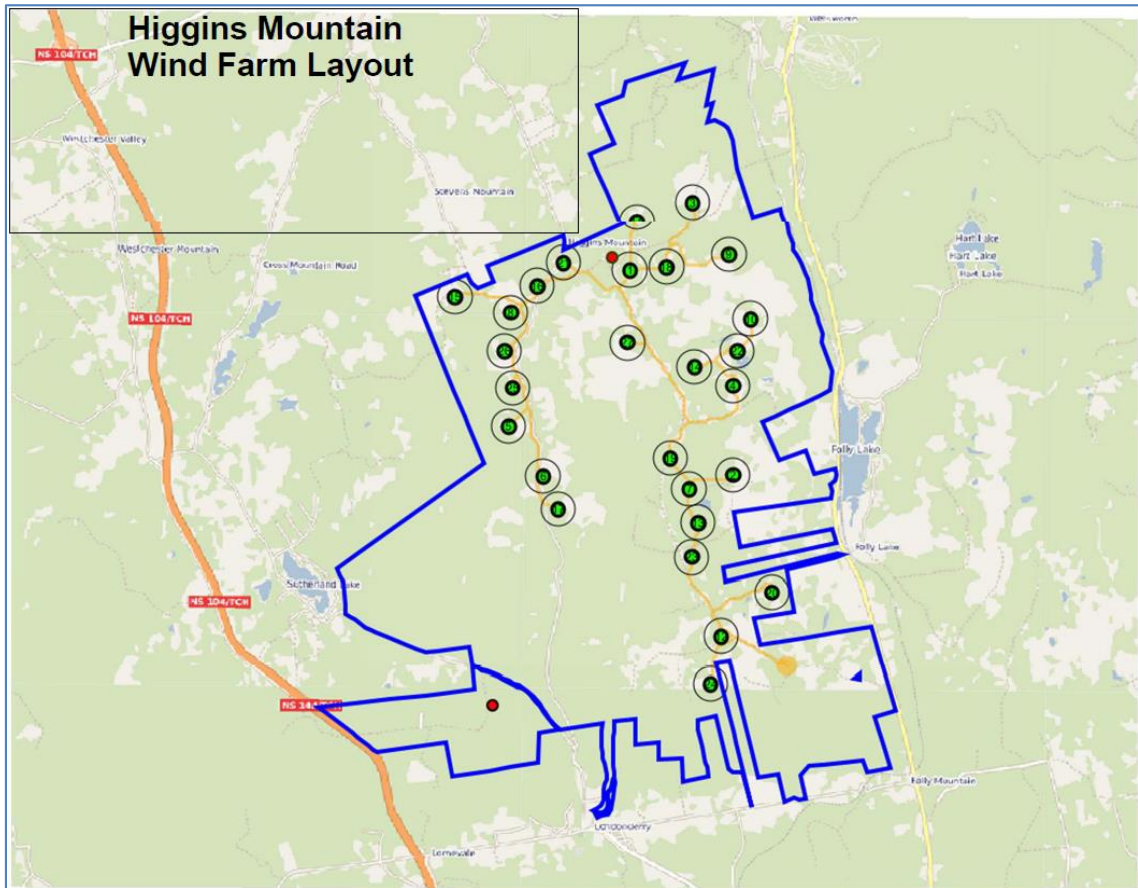

Figure 1: IR623 physical location

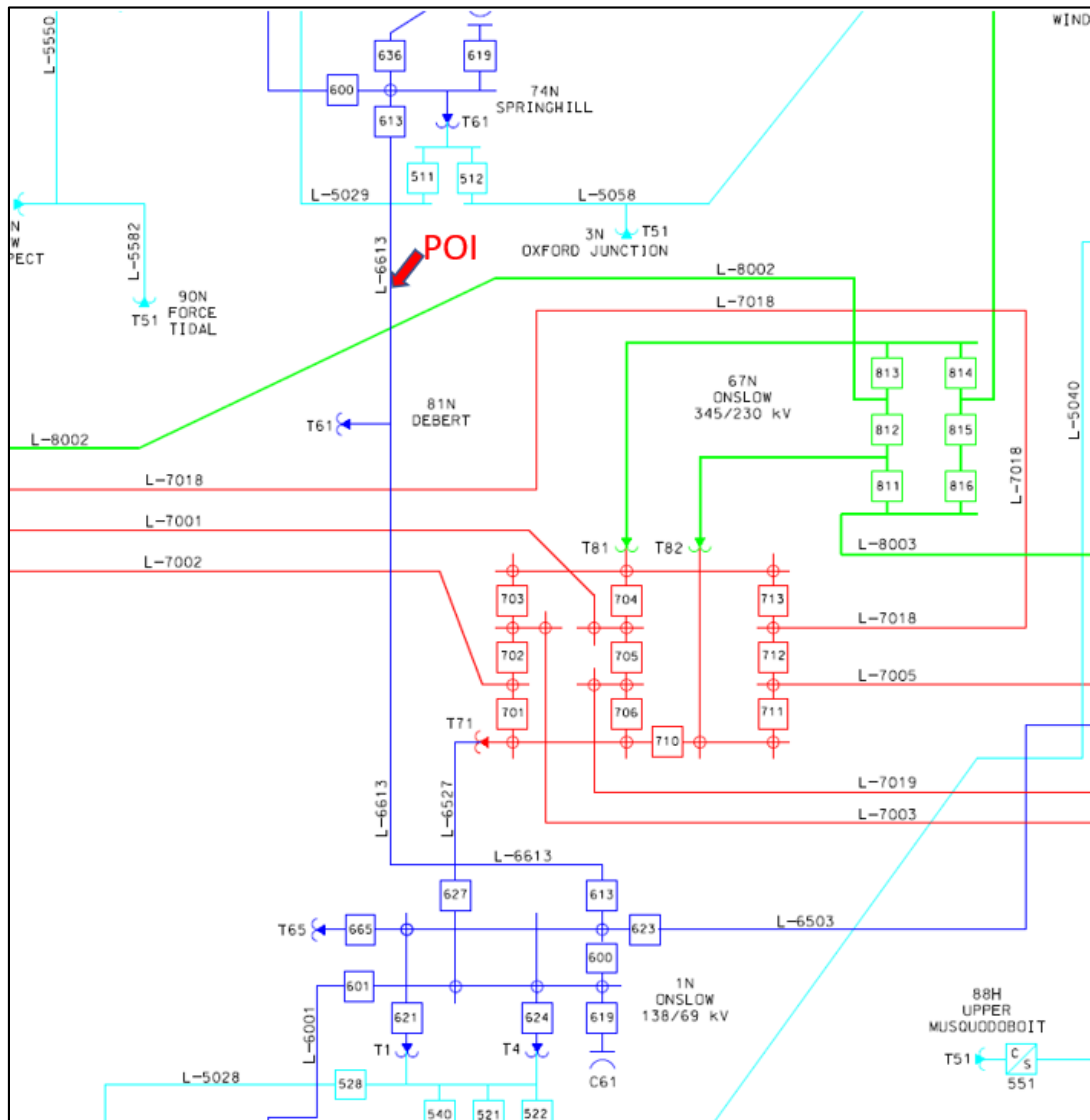

Figure 2: IR623 POI electrically (not to scale)

## 2.0 Scope

The objective of this Interconnection Feasibility Study (FEAS) is to provide a preliminary evaluation of system impacts from interconnecting the proposed generation facility to the NSPI transmission system at the requested location. The assessment will identify potential impacts on transmission element loading, which must remain within their thermal limits. Any potential violations of voltage criteria will be identified and addressed. If the proposed generation increases the short-circuit duty of any circuit breakers beyond their rated capacity, the circuit breakers must be upgraded.

The scope of the FEAS includes the modelling of the power system in normal state (with all transmission elements in service) under anticipated load and generation dispatch



conditions. A power flow and short circuit analysis will be performed to provide the following information:

- Preliminary identification of any circuit breaker short circuit capability limits exceeded as a result of the interconnection, and any network upgrades necessary to address the short circuit issues associated with the IR.
- Preliminary identification of any thermal overload or voltage limit violations resulting from the interconnection and identification of the necessary network upgrades to allow full output of the proposed facility.
- Preliminary description and high-level non-binding estimated cost to construct the facilities required to interconnect the generating facility to the transmission system.

This FEAS is based on a power flow and short circuit analysis and does not include a complete determination of system and facility changes/additions required to increase the system transfer capabilities that may be required to meet the design and operating criteria established by NSPI, the Northeast Power Coordinating Council (NPCC), and the North American Electric Reliability Corporation (NERC). These requirements will be determined by a more detailed analysis in the subsequent interconnection System Impact Study (SIS). An Interconnection Facilities Study (FAC) follows the SIS to ascertain the final cost estimate to interconnect the generating facility.

Applicable planning criteria as approved for use in Nova Scotia by the Utility and Review Board, are used in evaluation of the impact of any facility on the Bulk Electric System.

### 3.0 Assumptions

#### 3.1 System Assumptions

As mentioned in section 4.0 Projects with Higher Queue Positions, TSR411 is not included in this feasibility assessment of IR623.

The power flow cases used for this feasibility assessment contain only transmission connected generating facilities. Distribution connected generating facilities are generally netted with distribution loads.

The thermal ratings of L-6613 thermal ratings are shown in Table 1.

NSPI Transmission Line Ratings														Last Updated: 2021-08-27	
LINE	STATION	CONDUCTOR			BREAKER		SWITCH		CURRENT TRANSFORMER			TRIP MVA			
		Type	Maximum Operating Temp. (Celsius)	SUMMER RATING 25 DEG (MVA)	WINTER RATING 5 DEG (MVA)	100% Name-plate	100% Name-plate	RELAYING			FULL SCALE METERING				
								Ratio	R.F.	MVA	Ratio	R.F.	MVA		
L-6613	1N Onslow	ACSR 1113 Beaumont	100	320	363	478	287	800	2	382	1200	1	332	522	
	74N Springhill					287	287	600	2	287	1200	1	300	357	

Table 1: L-6613 ratings

### 3.2 Project Assumptions

This FEAS is based on the technical information provided by the Interconnection Customer. The configuration studied is as follows:

1. The service will be Network Resource Interconnection Service (NRIS) per the Generator Interconnection procedures (GIP). IR623 generation is for use in NS and not for export outside NS and displaces planned phased out coal generation in Cape Breton and not generation in Halifax, NS.
2. Commercial Operation Date of March 31, 2024.
3. The Interconnection Facility is modelled based on the information provided by the IC as per section 1.0 Introduction.
4. The generation technology used must meet NSPI requirements for reactive power capability of at least 0.95 capacitive to 0.95 inductive at the HV terminals of the IC Substation Step Up transformer. It is also required to have high-speed Automatic Voltage Regulation to maintain constant voltage at the designated voltage control point during and following system disturbances as determined in the subsequent System Impact Study. The designated voltage control point will either be the low voltage terminals of the wind farm transformer, or if the high voltage terminals are used, equipped with droop compensation controls. It is assumed that the generating units are not de-rated in their MW capability when delivering the required reactive power to the system.
5. The information on collector circuits was not adequate for estimating the equivalent impedances, so assumed values were used. The subsequent SIS can obtain the details from the IC and do the correct modelling of the collector circuits at that time.
6. The FEAS analysis is based on the assumption that IR's higher in the Generation Interconnection Queue and OATT Transmission Service Queue that have completed a System Impact Study, or that have a System Impact Study in progress will proceed, as listed in Section 4 below, with the exception of TSR411 as discussed earlier in the report.

7. It is required, as specified in the TSIR, that the wind turbines are equipped with a “cold weather option” suitable for delivering full power under expected Nova Scotia winter environmental conditions.
8. It is the IC’s responsibility that the new facility will meet all requirements of NSPI’s GIP and NSPI’s Transmission System Interconnection Requirements.

## 4.0 Projects with Higher Queue Positions

All in-service generation in NS is included in the FEAS, except for Lingan Unit 2, which is assumed to be retired.

Figure 3 shows the GIP queue as of October 15, 2021.

Combined T/D Advanced Stage Interconnection Request Queue													
Publish Date: Friday, October 15, 2021													
Queue Order	IR #	Request Date DD-MMM-YY	County	MW Summer	MW Winter	Interconnection Point Requested	Type	Inservice date DD-MMM-YY	Revised Inservice date	Status	Service Type	IC Identity	
1	-T	426	27-Jul-12	Richmond	45	45	47C	Biomass	01-Jan-17	01/09/2018	GIA Executed	NRIS	N/A
2	-T	516	05-Dec-14	Cumberland	5	5	37N	Tidal	01-Jul-16	31/05/2020	GIA Executed	NRIS	N/A
3	-T	540	28-Jul-16	Hants	14.1	14.1	17V	Wind	01-Jan-18	31/10/2023	GIA Executed	NRIS	N/A
4	-T	542	26-Sep-16	Cumberland	3.78	3.78	37N	Tidal	01-Jan-19	01/11/2021	GIA Executed	NRIS	N/A
5	-D	557	19-Apr-17	Halifax	5.6	5.6	24H	CHP	01-Sep-18		SIS Complete	N/A	N/A
6	-D	569	26-Jul-19	Digby	0.6	0.6	509V-302	Tidal	01-Mar-21	30/07/2021	GIA Executed	N/A	N/A
7	-D	568	21-May-19	Cumberland	2	2	22N-404	Solar	01-Sep-20	01/09/2021	GIA Executed	N/A	N/A
8	-D	566	16-Jan-19	Digby	0.7	0.7	509V-301	Tidal	31-Jul-19	29/01/2021	GIA Executed	N/A	N/A
9	-T	574	27-Aug-20	Hants	58.8	58.8	L-6051	Wind	30-Jun-23		FAC Complete	NRIS	N/A
10	-D	595	11-Mar-21	Halifax	0.1	0.1	1H-454	Battery	11-Jan-21		SIS Complete	N/A	N/A
11	-T	598	13-May-21	Cumberland	2.52	2.52	37N	Tidal	01-Dec-22		SIS in Progress	NRIS	N/A
12	-D	604	07-Jun-21	Cape Breton	0.45	0.45	11S-303	Solar	15-Jan-22		SIS in Progress	N/A	N/A
13	-D	603	31-May-21	Cumberland	0.4	0.4	22N-404	Solar/Battery	16-Feb-22		SIS in Progress	N/A	N/A
14	-D	600	27-May-21	Halifax	0.6	0.6	99H-312	Solar/Battery	02-Mar-22		SIS in Progress	N/A	N/A
<b>Totals:</b>					139.65	139.65							

Figure 3: GIP Queue

The following projects are higher queued in the Advanced Stage Interconnection Request Queue and are committed to the study:

- IR426: GIA executed
- IR516: GIA executed
- IR540: GIA executed
- IR542: GIA executed
- IR557: SIS complete
- IR569: GIA executed

- IR568: GIA executed
- IR566: GIA executed
- IR574: FAC Complete
- IR595: SIS complete
- IR598: SIS in Progress
- IR604: SIS in Progress
- IR603: SIS in Progress
- IR600: SIS in Progress

The transmission connected IRs are modelled in the transmission network for analysis.

Figure 4 shows the Transmission Service Request (TSR) queue on January 22, 2022 is used in lieu of October 15, 2021.

OATT Transmission Service Queued System Impact Studies Active January 22, 2022							
Item	Project	Date & Time of Service Request	Project Type	Project Location	Requested In-Service Date	Project Size (MW)	Status
1	TSR 400	July 22, 2011	Point-to-point	NS-NB*	May 2019	330	System Upgrades in Progress
2	TSR 411	January 19, 2021	Point-to-point	NS-NB*	January 1, 2025	550	SIS in Progress
3	TSR 412	January 19, 2021	Point-to-point	Woodbine - NS	January 1, 2025	500	Withdrawn

\*Indicates project as being located near provincial border.

Figure 4: TSR Queue

TSR400 has a firm export from NS to NB of 150 MW in winter and 330 MW in summer. This is a “through NS” export from NL via the Maritime Link (ML) HVDC to the NS and NB border, and NS does not carry the operating reserve for it. The sink entity will be responsible for that reserve. In the event of a loss of ML HVDC under this condition, NS will cut the 150 MW or 330 MW “through NS” export.

Regarding TSR411, it is expected to be in service in 2025 and system studies are currently underway to determine the required upgrades to the Nova Scotia transmission system. As a result, the following notice has been posted to the OASIS site at <https://www.nspower.ca/oasis/generation-interconnection-procedures>:

*Effective January 19th, 2021, please be advised that the completion of advanced-stage Interconnection Studies under the Standard Generator Interconnection Procedures (GIP) may be delayed pending the outcome of the Transmission Service Request (TSR) 411 System Impact Study, which is expected to identify significant changes to the NSPI transmission system. The revised expected completion date for*

*the study is February 28, 2022. Feasibility Studies initiated prior to the completion of the TSR System Impact Study will be performed based on the current system configuration.*

## 5.0 Short-Circuit Duty / Short Circuit Ratio

The maximum (design) expected short-circuit level is 5,000 MVA on 138 kV systems. Short circuit analysis is based on ASPEN One-Liner v14.4 short circuit case that is maintained and updated by NSPI system protection department for short circuit calculations. The case is imported into PSSE version 33.12.1 and the short circuit analysis is performed in PSSE with higher queued projects and IR623 added to the PSSE models.

IR623 short circuit capability used for this assessment is based on the wind turbine technical bulletin provided by the IC as per section “1.0 Introduction”. The short circuit calculations are based on three-phase-fault and flat voltage profile at one per unit voltage. Minimum generation has only the Maritime Link, Point Aconi, Lingan 1, and Trenton 6 in NS in service under the present system operating requirements.

Table 2 shows maximum short circuit levels at 1N-Onslow, 74N-Springhill, 81N-Debert, IR623 POI, 34.5 kV bus, and 690 V generating bus.

Maximum System Normal Three Phase Short Circuit in MVA						
Case	1N Onslow	74N Springhill	81N Debert	IR623 POI	IR623 34.5kV	IR623 690V
IR623 Off	2,324	1,288	1,632	1,290	334	289
IR623 On	2,420	1,351	1,752	1,470	639	646

Table 2: Maximum generation short circuit level system normal

The interrupting capability of the 138 kV circuit breakers at 138 kV substations in NS is at least 3,500 MVA, much higher than the maximum short circuit levels at these locations with IR623 being on-line, hence IR623 will not incur any breaker upgrades at these substations.

As for the minimum short circuit level, Table 3 shows minimum short circuit levels at IR623 POI, 34.5 kV bus and 690 V equivalent generator terminal bus.

Minimum System Normal Three Phase Short Circuit in MVA			
Case	IR623 POI	IR623 34.5kV	IR623 690V
IR623 Off	967	322	282
IR623 On	1,147	627	639

Table 3: Minimum generation short circuit level system normal

Table 4 shows minimum short circuit levels at IR623 POI, 34.5 kV bus and 690 V equivalent generator terminal bus with L-6613 out of service between IR623’s POI and

81N-Debert substation or between 81N-Debert substation and 1N-Onslow substation. These fault levels are lower than the values of other single element outage at 1N-Onslow or at 67N-Onslow substations.

<b>Minimum Three Phase Short Circuit in MVA with L-6613 Outage</b>			
<b>Case (IR623 to Debert Out)</b>	<b>IR623 POI</b>	<b>IR623 34.5kV</b>	<b>IR623 690V</b>
IR623 Off	463	241	219
IR623 On	644	547	576

**Table 4: Minimum generation short circuit level with 67N-T71 Out**

Table 4 system three phase short circuit (with IR623 off-line) at 34.5 kV is 241 MVA, which equates to the short circuit ratio (SCR) of 2.41, less than the minimum 2.5 for these wind turbines. It is recommended that the IC should discuss with the wind turbine supplier for low SCR options.

## **6.0 Voltage Flicker and Harmonics**

The voltage flicker can't be determined due to lack of information at this time. The harmonic levels are provided for a 69kV connection, and not for a 138kV connection. Hence, the subsequent SIS can obtain the required information and to determine if the requirements are met.

## **7.0 Thermal Limits**

### **7.1 NS Load Forecast**

At the time of this assessment for IR623, the latest NSPI corporate load forecast available was in the “2021 Ten Year System Outlook” report issued by NS Power June 30, 2021. The load forecast for the year 2031 has NS system peak forecast of 2,262 MW with a firm peak of 2,057 MW. The total net system load includes system losses but excludes power plant station service loads.

The winter peak load for NS is modeled based on the above load forecast.

### **7.2 IR623 Model**

Based on the information provided by the IC, the following was determined and modelled for IR623:

1. The POI to L-6613 is modelled at 30 km in length from 1N-Onslow substation.
2. The spur 138 kV line from POI to the IC's 138 kV to 34.5 kV substation is modelled with a length of 3.51km.
3. The IC provided conflicting information regarding the two 138kV to 34.5 kV transformers. The form shows two 25/42 MVA transformers whereas the one-line shows two 30/40/50 MVA transformers. This feasibility assessment uses the values as indicated on the one-line.
4. The 34.5 kV to 690 V transformers are modelled based on 5.75% positive impedance and 1% resistance on 4.5 MVA base rating. An equivalent model for 27 units was modelled.
5. The equivalent generator for the 27 wind turbines is modelled based on the information provided by the IC for each wind turbine of 3.83 MW, 4.256 MVA, +/- 1.855 MVAR for the total output of 100 MW at 690 V.
6. The information on collector circuits was not adequate for estimating the equivalent impedances, so assumed values were used. The subsequent SIS can obtain the details from the IC and do the correct modelling of the collector circuits at that time.

### 7.3 IR623 Steady State Analysis Result

This feasibility assessment is completed based on IR623 output being used in NS, not for exporting outside NS, and displacing planned phased out coal generation in Cape Breton as per NSPI's present plan and guidelines for these feasibility assessments. The guidelines include all wind farms in NS to be dispatched at full outputs in two seasons, winter peak and summer peak.

The present NB to NS firm import is zero. The base cases are dispatched with NB to NS at 142.5 MW to allow ten-minute reserve delivery from NB to NS.

The present NS to NB firm export is 150 MW in winter season and 330 MW in non-winter season. The base cases are dispatched with NS to NB at 320 MW in winter peak and 500 MW in summer peak to allow for the ten-minute reserve delivery from NS to NB together with firm export.

In order to maintain ONS or CBX power flow within the existing established operating limits, ten-minute operating reserve from NS to NB may need to come from Burnside units. In addition, these units can be dispatched as synchronous condensers as needed to meet the Metro Dynamic Reactive Reserve requirements.



For each system dispatch chosen, a steady state analysis is performed and checked for the system performance with IR623 off-line and with IR623 on-line at full output in order to determine any thermal overload or voltage violation directly caused by IR623.

System dispatch cases were created based on the above conditions using PSSE software version 33.12.1. The power flows of various interfaces inside and outside NS are displayed in Table 5.

Case Name	NB to NS	NB to PEI	NB to NE	NL to NS	NB to HQ	CBX	ONI	ONS	TC	TR	PT2	LG	PA	BS	VJ	TUS	WC	IR623 Wind	Total Trans Wind
C01a_WP_R1.sav	142.5	150	0	475	-928	869	948	980	78	165	80	266	185	0	0	23	192	0	489
C01b_WP_R1.sav	142.5	150	0	475	-928	768	853	981	78	165	80	162	185	0	0	23	192	100	589
C02a_WP_R1.sav	-320	250	0	475	-928	1237	1273	839	104	150	165	494	189	100	0	33	192	0	489
C02b_WP_R1.sav	-320	250	0	475	-928	1131	1177	840	103	150	165	384	189	100	0	33	192	100	589
C03a_SP_R1.sav	142.5	150	800	475	-785	424	424	532	0	0	0	315	0	0	0	0	0	0	489
C03b_SP_R1.sav	142.5	150	800	475	-785	326	329	532	0	0	0	214	0	0	0	0	0	100	589
C04a_SP_R1.sav	-500	236	800	475	-785	839	971	430	0	157	0	368	190	100	0	0	140	0	489
C04b_SP_R1.sav	-500	236	800	475	-785	737	874	430	0	157	0	262	190	100	0	0	140	100	589

Table 5: Power system cases

Applicable contingencies in NS and some contingencies in NB around Memramcook substation were simulated in steady state for the above cases. These contingencies are shown in Table 6. For load flow, 67N-815 contingency is the same as L-8001 contingency and 67N-816 contingency is the same as L-8003 contingency due to the empty node between 67N-815 breaker and 67N-816 breaker. In NS, system normal uses Rate A and N-1 contingencies use Rate B, whereas in NB, system normal uses Rate A and N-1 contingencies use Rate C. Contingencies marked with \* denotes applicable in service SPS may be armed.

Contingencies Studied				
101S_701	120H_710	30N_B61	67N_706	90H_609
101S_702	120H_711	30N_T61	67N_710	90H_611
101S_703	120H_712	3C_711	67N_713	90H_612
101S_704	120H_713	3C_712	67N_811*	90H_T1
101S_705	120H_714	3C_713	67N_812	91H_511
101S_706	120H_715	3C_714	67N_813	91H_513
101S_711	120H_716	3C_715	67N_814	91H_516
101S_712	120H_690	3C_716	67N_T71	91H_521
101S_713	120H_SVC	3C_T71	67N_T81	91H_523
101S_811	120H_T71	3C_T72	67N_T82	91H_603
101S_812*	120H_T72	3C710*	67N711*	91H_604
101S_813*	132H_602	3C690*	67N712*	91H_605
101S_814*	132H_603	3S_T1	70037004*	91H_606



## Interconnection Feasibility Study Report

Contingencies Studied				
101S_816	132H_605	47C_602	70087009Sep	91H_607
101S_T81	132H_606	47C_603	74N_B61	91H_608
101S_T82	1C_689	47C_674	74N_T61	91H_609
103H_600	1C_B61	47C_T63	79N-T81*	91H_611
103H_608	1C_B62	47C_T64	85S_B61	91H_613
103H_681	1C_G2	47C_T65	85S_G1	91H_621
103H_881	1N_600	47C_T67	88S_710	91H_T11
103H_B61	1N_601	49N_600	88S_711	91H_T62
103H_B62	1N_613	4C_T2	88S_712	91H_TC3
103H_T81	1N_B51	4C_T63	88S_713	91N_701
104H600	1N_B52	50N_500	88S_714	IR639_POI
108H_600	1N_B61	50N_604	88S_715	L-5003
108H_B1	1N_B62	50N_B55	88S_690	L-5011
108H_B3	1N_C61	50N_B57	88S_721	L5012
113H_600	1N_T1	50N_G6	88S_722	L-5014
120H_621	1N_T4	50N_T12	88S_723*	L-5015
120H_622	2CB61WC1	50N_T8	88S_G4	L-5016
120H_623	2CB62WC1	50NB61G6	88S_T71	L-5017
120H_624	2S_513	50NB62G5	88S_T72	L-5019
120H_625	2S_600	67N_701	89S_G1	L-5020
120H_626	2S_B64	67N_702	90H_602	L1108
120H_627	2S_B65	67N_703	90H_603	L1142
120H_628	2S_T1	67N_704	90H_604	L1108
120H_629	L-5534	L6012	L6523	L1142
L-5021	L-5535	L6013	L6613a(1N-IR623)	L1143
L-5022	L-5536	L6014	L6613b(74N-IR623)	L1148-L1151*
L-5023L5053	L-5537	L6015	L6535	L1157
L-5024	L-5538	L6016	L6536	L1190
L-5025	L-5539	L6020	L6537*	L1190-L1215
L-5026	L-5541	L6021	L6538	L1244
L-5027	L-5546	L6024	L6539	L3004
L-5028	L-5547L5551	L6025	L6551	L3006
L-5029L5030	L-5548	L6033	L6552	L3013
L-5032L5004	L-5549	L60335039	L7001	L3017_3019
L-5033	L-5550L5582	L60336035	L7002	Lepreau
L-5035	L-5559L5579	L6035	L7003	ME1-10
L-5036	L-5560	L6038	L7004	ME1-11
L-5037L3031	L-5561L5565	L6040	L7005*	ME1-12

Contingencies Studied				
L-5039	L-5563	L60406042	L7008	ME1-13
L-5040	L-5564L5576	L6042	L7009	ME1-14
L5041	L-5571	L6043	L7011	ME1-15
L-5042	L-5573L5575	L6044	L7012	ME1-16
L5049	L-5580	L6047	L7014	ME1-6
L-5054	L6001	L6048	L7015	ME1-7
L-5058	L6002_90H	L6051	L7019	ME1-8
L-5500	L6002_99W	L6052	L7021	ME1-9
L-5501	L6003	L6053	L70216534	ME3-1*
L-5502	L60036007	L6054	L7022	ME3-2*
L-5505	L60036009	L6055	L8001*	ME3-3*
L-5506	L6004	L6503	L8002	Mem_T3
L-5507L5508	L6005	L6507	L80027009	
L-5511	L60056010	L65076508	L8003*	
L-5512	L60056016	L6508	L8004*	
L-5521	L6006	L6510	ML_2Poles	
L-5524	L6007	L6511	ML_Pole1	
L-5527A	L6008	L6514	ML_Pole2	
L-5527B	L6009	L6515	PHP	
L-5530	L6010	L6516	90H_605	
L-5531	L60106011	L6517	90H_606	
L-5532	L6011	L6518	90H_607	
L-5533L5581	2S_T2	67N_705	90H_608	

Table 6: Contingencies in NS and NB studied

The load flow results show that, when IR623 NRIS 100 MW output is used in NS and displaces the planned phased out coal generation in Cape Breton as per NSPI’s generation plan, IR623 does not violate thermal limit criteria.

Unrelated to any system issue, regarding the two 138 kV to 34.5 kV, 30/40/50 MVA transformers for the interconnection of IR623 to L-6613, it is noted that IR623 can generate up to 100MW and provide up to +/- 50.1 MVAR, for a total of 112 MVA. Even with power losses in the individual wind turbine transformers, the collector circuits, and the two 138 kV to 34.5 kV transformers, the loading on these two transformers can exceed 100 MVA under some system conditions. It is recommended that the IC will re-assess the size of these transformers.

## 8.0 Voltage Limits

The load flow results show that, when IR623 rated output is used in NS and displaces the planned phased out coal generation in Cape Breton as per NSPI’s plan, IR623 does not violate voltage criteria.

As for power factor, NSPI requires IR623 to meet  $|+/-0.95|$  or less on the high voltage side of the IC substation transformer.

Figure 5 shows power factor on the high voltage side of the IC substation transformer when IR623 generates maximum reactive power output. Table 7 shows that IR623 does not meet NSPI’s required power factor of  $|+0.95|$  or less, hence IR623 will require power factor correction. This will be further examined in the SIS as the collector circuit impedances were not provided for this feasibility assessment and assumed values were used.

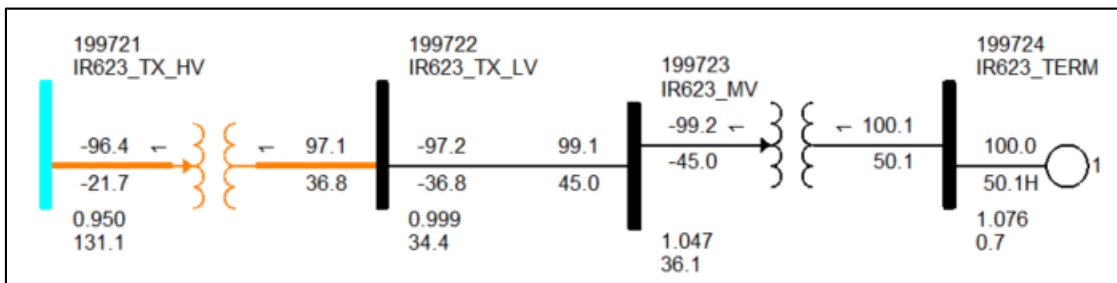

Figure 5 Power Factor with Qmax

IR623 Max MW	IR623 Max MVAR	Tx HV MW	Tx HV MVAR	Tx HV Power Factor
100.0	50.1	96.4	21.7	0.98

Table 7: Power factor with Qmax

Figure 6 shows power factor on the high voltage side of the IC substation transformer when IR623 absorbs maximum reactive power output. Table 8 shows that IR623 meets NSPI’s required power factor of  $|-0.95|$  or less when it absorbs reactive power from the system. This will be further examined in the SIS as the collector circuit impedances were not provided for this feasibility assessment and assumed values were used.

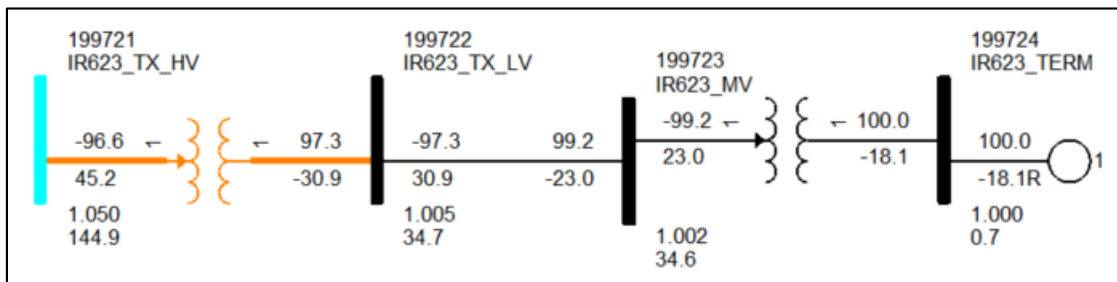

Figure 6 Power Factor with Qmin

IR623 Max MW	IR623 Max MVAR	Tx HV MW	Tx HV MVAR	Tx HV Power Factor
100.0	-18.1	96.6	-45.2	0.906

Table 8: Power factor with Qmin

A centralized controller will be required which continuously adjusts individual generator reactive power output within the plant capability limits and regulates the voltage at the 34.5 kV bus voltage. The voltage controls must be responsive to voltage deviations at the terminals of the Interconnection Facility substation; be equipped with a voltage set-point control; and also have the ability to slowly adjust the set-point over several (5-10) minutes to maintain reactive power within the individual generators capabilities (Please refer to NSPI’s TSIR). The details of the specific control features, control strategy and settings will be reviewed and addressed in the SIS, as will the dynamic performance of the generator and its excitation. Line drop compensation, voltage droop, control of separate switched capacitor banks must be provided.

The NSPI System Operator must have manual and remote control of the voltage set-point and the reactive set-point of this facility to coordinate reactive power dispatch requirements.

This facility must also have low voltage ride-through capability as per NSPI’s TSIR. The SIS will state specific options, controls and additional facilities that are required to achieve this.

## 9.0 System Security / Bulk Power Analysis

L-6613 is classified as BPS (Bulk Power System) as defined by NPCC and BES (Bulk Electricity System) as defined by NERC. L-6613 is currently on NSPI’s 2021 BPS list and BES list, hence IR623 interconnection to L-6613 will be required to meet NPCC and NERC requirements. The SIS will determine BPS and BES status for POI substation, the spur 138kV line, and the IC substation. As IR623 will generate more than 75 MW, the generating facility will be BES and will be subjected to NERC standards that applied to BES.

## 10.0 Loss Factor

The Loss Factor calculation is based on a system winter peak load case and is used only for comparison purposes. The winter peak load flow case is simulated with and without the new facility in service, while keeping 91H-Tufts Cove Generator TC3 as the NS Area Interchange generator, the tie flow between NB and NS at zero, and the Brushy Hill SVC at floating. This methodology reflects the load centre in and around 91H-Tufts Cove. A negative loss factor reflects a reduction in system losses.

The loss factor for IR623 is shown in Table 9:

Loss Factor	
Description	MW
IR623 On	100
TC3 with IR623 On	69.3
TC3 with IR623 Off	160
IR623 Loss Factor	+9.3%

Table 9: Loss factor

## 11.0 Expected Facilities Required for Interconnection

The following facility changes will be required to connect IR623 to L-6613.

### a. Required Network Upgrades

- Modification of NSPI protection systems at 1N-Onslow and 74N-Springhill for L-6613.
- Install a new 138kV substation complete with a 3 breaker ring bus at the POI to L-6613 and control and protection as acceptable to NSPI. A Remote Terminal Unit (RTU) to interface with NSPI’s SCADA, with telemetry and controls as required by NSPI. The IC will be responsible for obtaining the land and access for this new substation.

### b. Required Transmission Provider’s Interconnection Facilities (TPIF):

- Install 3.51 km of 138 kV spur line from POI to the IC substation. The IC will be responsible for obtaining and providing the ROW.
- Add P&C, control and communications between the wind farm and NSPI SCADA system (to be specified).

### c. Required Interconnection Customer’s Interconnection Facilities (ICIF)

- Facilities to provide 0.95 leading and lagging power factor when delivering rated output at the HV terminals of the IC Substation Step Up Transformer when the voltage at that point is operating between 95 and 105 % of nominal.
- Centralized controls. These will provide centralized voltage set-point controls and are known as Farm Control Units (FCU). The FCU will control the 34.5 kV bus voltage and the reactive output of the machines. Responsive (fast-acting) controls are required. The controls will also include a curtailment scheme which will limit or reduce total output from the facility, upon receipt of a telemetered signal from NSPI’s SCADA system. Please refer to NSPI’s TSIR for additional requirements

such as primary frequency responses (curtailed and un-curtailed), full reactive power capability over active power range and voltage/frequency ride through.

- NSPI will have control and monitoring of reactive output of this facility, via the centralized controller. This will permit the NSPI Operator to raise or lower the voltage set-point remotely.
- Low voltage ride-through capability per Nova Scotia Power Transmission System Interconnection Requirements (TSIR) document.
- Real-time monitoring (including an RTU) of the interconnection facilities. Local wind speed and direction, MW and MVAR, as well as bus voltages are required.
- Facilities for NSPI to execute high speed rejection of generation (transfer trip) if determined in SIS. The plant may be incorporated into SPS run-back schemes.
- Automatic Generation Control to assist with tie-line regulation.
- The facility must meet NSPI's TSIR as published on the NSPI OASIS site at <https://www.nspower.ca/oasis/standards-codes>.

## 12.0 Facilities and Network Upgrades Cost Estimate

The cost estimates for NSPI Interconnection Facilities (IF) and Network Upgrades for interconnecting IR623 to L-6613 are shown in Table 10.

Please note that this cost estimate is high level, non-binding in 2022 Canadian dollars. This does not include additional costs to be identified by the subsequent SIS and Facility Study.

L-6613 is classified as BPS (Bulk Power System) and BES (Bulk Electricity System) in NSPI's 2021 BPS list and BES list, hence the requirement for a three-breaker ring bus substation as per NSPI's "Transmission System Interconnection Requirements", dated February 25, 2021, Version 1.1. The design will meet applicable NPCC and NERC requirements. Since IR623 aggregate generation is greater than 75 MW, it requires to meet NERC BES requirements.

Item	Network Upgrades	Estimate
I	P&C modifications at 1N-Onslow and 74N-Springhill for L-6613	\$400,000
II	Three breaker ring bus 138 kV NSPI IF substation complete with P&C and connection to L-6613	\$6,250,000
	Sub-total	\$6,650,000
Item	TPIF Upgrades	Estimate
I	Install a new 3.51 km of wood H-frame 138 kV spur line to connect to IR623 to L-6613	\$1,760,000
II	P&C relaying equipment	\$100,000
III	NSPI supplied RTU	\$65,000
IV	Tele-protection and SCADA communications	\$150,000
	Sub-total	\$2,075,000
Item	Total Upgrades	Estimate
	Network Upgrades + TPIF Upgrades	\$8,725,000
	Contingency (10%)	\$872,500
	Total (Excl. HST)	\$9,597,500

Table 10: Cost estimates

### 13.0 Preliminary Scope of the SIS

The following provides a preliminary scope of work for the subsequent SIS for IR623. The SIS will include a more comprehensive assessment of the technical issues and requirements to interconnect generation as requested. It will include contingency analysis, system stability, ride through, and operation following a contingency (N-1 operation). The SIS must determine the facilities required to operate this facility at full capacity, withstand any contingencies (as defined by the criteria appropriate to the location) and identify any restrictions that must be placed on the system following a first contingency loss. The SIS will confirm the options and ancillary equipment that the customer must install to control flicker, voltage, frequency response, active power, low voltage ride-through, frequency ride-through, and power factor to meet NSPI TSIR requirements. The SIS will be conducted in accordance with the GIP with the assumption that all appropriate higher-queued projects will proceed and the facilities associated with those projects are installed.

The following outline provides the minimum scope that must be complete in order to assess the impacts. It is recognized the actual scope may deviate, to achieve the primary objectives. The SIS will consider but not be limited to the following:

- 1) Correct models of the entire facility from the POI to the IC substation and IR623 facility including the collector circuits.

- 2) Facilities that the customer must install to meet the requirements of the GIP and NSPI's latest version of "Transmission System Interconnection Requirements", informally referred to as NSPI's Grid Code.
- 3) The minimum transmission additions/upgrades that are necessary to permit operation of this Generating Facility, under all dispatch conditions, meeting NPCC and NERC criteria.
- 4) Guidelines and restrictions applicable to first contingency operation (curtailments etc.).
- 5) Under-frequency load shedding impacts.
- 6) Metro Dynamic Reactive Reserves requirement, thermal and voltage assessment for increasing Onslow South if IR623 is required to displace generation at Tufts Cove instead of the planned phased out coal generation in Cape Breton as per NSPI's present generation plan.

The SIS will assess system contingencies such that the system performance will meet the following criteria:

- Table 1 "Planning Design Criteria" of NPCC Directory 1 latest revision as approved by NS-UARB.
- Table 1 "Steady State & Stability Performance Planning Events" of NERC TPL-001- latest revision as approved by NS-UARB.
- NSPI System Design Criteria, report number NSPI-TPR-003-4 latest revision as approved by NSPI and submitted to NS-UARB.

Additionally, electromagnetic transient study may be required to account for IR623 control system to coordinate with other facilities in the transmission system and to ensure fault ride through.

Any changes to SPS schemes required for operation of this generating facility, in addition to existing generation and facilities that can proceed before this project, will be determined by the SIS as well as any required additional transmission facilities. The determination will be based on all NERC and NPCC criteria approved by the UARB as well as NSPI guidelines and good utility practice. The SIS will also determine the contingencies for which this facility must be curtailed.

Nova Scotia Power Inc.  
Transmission System Operations  
2021-04-08