



Interconnection Feasibility Study Report GIP-IR632-FEAS-R1

**Generator Interconnection Request 632
96 MW Wind Generating Facility
Lunenburg County, NS**

2022-03-01

Control Centre Operations
Nova Scotia Power Inc.

Executive Summary

The Interconnection Customer (IC) submitted an Interconnection Request (IR#632) for Network Resource Interconnection Service (NRIS) or Energy Resource Interconnection Service (ERIS) for a proposed 96 MW wind generation facility interconnected to the NSPI transmission system, with a Commercial Operation Date of 2023-12-31. The Point of Interconnection (POI) requested by the customer is the 138kV line L-6025, with an alternate POI on the 138kV line L-6006. L-6025 and L-6006 run between 99W-Bridgewater and 50W-Milton and they both terminate on the same buses at each end. The proposed POI would both be approximately 20.3 km from the 99W-Bridgewater end. The alternate POI would only be considered if unexpected results not contemplated in the Scoping Meeting are found with the primary POI, which was found not to be the case for IR#632.

There are four transmission and three distribution Interconnection Requests currently in the Advanced Stage Transmission and Distribution Queue that must be included in the study models for IR#632. In addition, there is one long-term firm transmission service reservation in the amount of 550 MW from New Brunswick to Nova Scotia (TSR-411). This transmission service request is expected to be in service in 2025 and system studies are currently underway to determine the associated upgrades to the Nova Scotia transmission system. These upgrades are expected to materially alter the configuration of the transmission system in Nova Scotia. As a result, the following notice has been posted to the OASIS site at <https://www.nspower.ca/oasis/generation-interconnection-procedures>:

Effective January 19th, 2021, please be advised that the completion of advanced-stage Interconnection Studies under the Standard Generator Interconnection Procedures (GIP) may be delayed pending the outcome of the Transmission Service Request (TSR) 411 System Impact Study, which is expected to identify significant changes to the NSPI transmission system. The revised expected completion date for the study is February 28, 2022. Feasibility Studies initiated prior to the completion of the TSR System Impact Study will be performed based on the current system configuration.

This study assumes that the addition of generation from IR#632 will displace coal-fired generation in eastern Nova Scotia for both NRIS and ERIS.

The assessment of the POI on the 138kV line L-6025 indicated that under certain operating conditions, L-6531 could exceed its emergency operating limit for contingencies that result in the loss of bus 99W-B61. As an alternative to upgrading L-6531, it is recommended that transfer-trip protection cross-trip breaker 50W-625 whenever breaker 99W-625 operates. This will isolate IR#632, but this would be the case for any faults on L-6025.

The Network Upgrade transfer trip to 50W-625 for opening of breaker 99W-625 would not be necessary under ERIS if IR#632 is limited to 55 MW under certain operating conditions, estimated to occur approximately 40 hours per year, in addition to any other operating conditions that require curtailment of wind energy resources.

No violations of voltage criteria were found for IR#632.

Control Centre Operations – Interconnection Feasibility Study Report

Although the IC indicated the POI would utilize a three-breaker ring bus, L-6025 is not classified as Bulk Power System therefore this interconnection will utilize a direct line tap with Transfer Trip protection. The IC will require a 138kV circuit breaker between the ICIF transformer and the line tap. Because IR#632 is a dispersed generation facility in excess of 75 MVA, Inclusion I4 of the NERC BES Definition would apply, and each generator would be classified as a Bulk Electric System element.

Data provided by the IC indicates that IR#632 may not be able to meet reactive requirements without additional reactive support. Based on the provided rated power factor of the Vestas V162 6 MW wind turbines, the provided impedances of the transformers and typical collector circuit impedances, approximately 11 Mvar of supplementary reactive support may be needed to meet the net power factor of +0.95 to -0.95 at the Interconnection Facility 138kV bus. As specific details of the collector circuits become available, the need for supplemental reactive power support will be further investigated in the System Impact Study.

No concern regarding high short-circuit level or voltage flicker was found for this project on its own, provided that the project design meets NSPI requirements for low-voltage ride-through, reactive power range and voltage control. Harmonics must meet the Total Harmonics Distortion provisions of IEEE 519. The minimum short circuit level at the Interconnection Facility 138kV bus is 708 MVA with all lines in service, and 483 MVA with L-6025 open between the POI and 99W-Bidgewater. The calculated minimum Short Circuit Ratio at the high voltage terminals of the Interconnection transformer was found to be 5.0, equal to the recommended minimum of 5.0 for the Vestas V162 6.0 MW.

The preliminary value for the unit loss factor is calculated as +0.2% at the POI on L-6025. Losses associated with the IC facilities (collector circuits, transformers) are excluded from this calculation.

The preliminary non-binding cost estimate for interconnecting 96 MW to the POI on L-6025 as NRIS, including the cost of line protection upgrade incorporating transfer-trip for L-6025 is \$1,551,000. The cost estimates include a contingency of 10%, and this estimate will be further refined in the System Impact Study and the Facility Study. In this estimate, \$600,000 of the amount (plus 10% contingency) represents Network Upgrade costs which are funded by the IC, but which are eligible for refund under the terms of the GIP. The remainder of the costs are fully funded by the IC. The estimated time to construct the Transmission Providers Interconnection Facilities is 18-24 months after receipt of funds and cleared right of way from the customer.

The estimated cost for interconnection of IR#632 under ERIS is \$1,441,000 including 10% contingency. Of this amount, Network Upgrade costs of \$500,000 for upgrade of L-6025 line protection plus 10% contingency, and is funded by the IC but eligible for a refund under the terms of the GIP. Under ERIS, IR#632 would be limited to 55 MW under certain operating conditions.

Because the analysis did not uncover any unexpected issues, the alternate POI on L-6006 was not considered.

Table of Contents

	Page
Executive Summary.....	ii
1 Introduction	1
2 Scope	3
3 Assumptions	4
4 Projects with Higher Queue Positions.....	6
5 Short-Circuit Duty / Short Circuit Ratio	6
6 Voltage Flicker and Harmonics.....	7
7 Load Flow Analysis	8
8 Reactive Power and Voltage Control	10
9 System Security / Bulk Power Analysis	13
10 Loss Factor	13
11 Expected Facilities Required for Interconnection	13
11.1 NRIS Requirements:.....	14
11.2 ERIS Requirements:.....	15
12 NSPI Interconnection Facilities and Network Upgrades Cost Estimate	15
13 Issues to be addressed in SIS	17

1 Introduction

The Interconnection Customer (IC) submitted an Interconnection Request for Network Resource Interconnection Service (NRIS) for a proposed 96 MW wind generation facility interconnected to the NSPI transmission system, with a Commercial Operation Date of 2023-12-31. The Point of Interconnection (POI) requested by the customer is the 138kV circuit L-6025, with an alternate POI at the 138kV circuit L-6006. L-6025 and L-6006 are on the same Right-of-Way and the proposed Interconnection Customer’s Interconnection Facility (ICIF) is given to be 75m from the POI (there is no spur line). The primary and alternate POI are approximately 20.3 km from the 99W-Bridgewater 138kV substation.

The IC signed a Feasibility Study Agreement to study the connection of their proposed generating facility to the NSPI transmission system dated 2021-10-14, and this report is the result of that Study Agreement. This project is listed as Interconnection Request 632 in the NSPI Interconnection Request Queue and will be referred to as IR#632 throughout this report. The study is to include Energy Resource Interconnection Service (ERIS) as well as NRIS.

Figure 1 shows the proposed geographic location of IR#632 in relation to the NSPI transmission system.

Figure 1 IR#632 Buckfield Site Location



Control Centre Operations – Interconnection Feasibility Study Report

Figure 2 is a simplified one-line diagram of the transmission system configuration near the proposed POI. Figure 3 shows the circuit breaker configuration of transmission lines in the vicinity of the POI.

Figure 2 Point of Interconnection (not to scale)

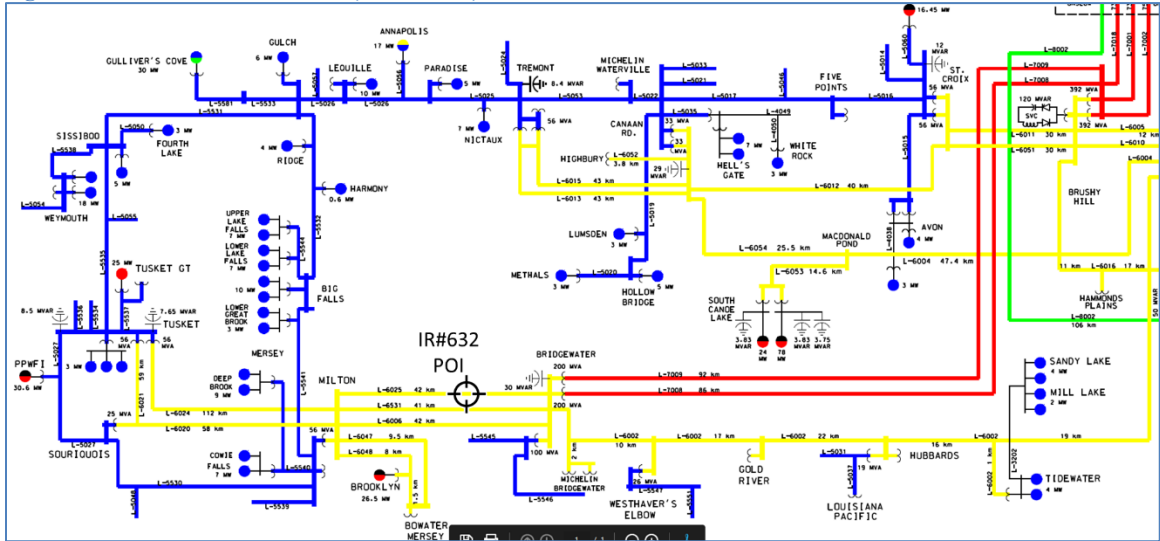
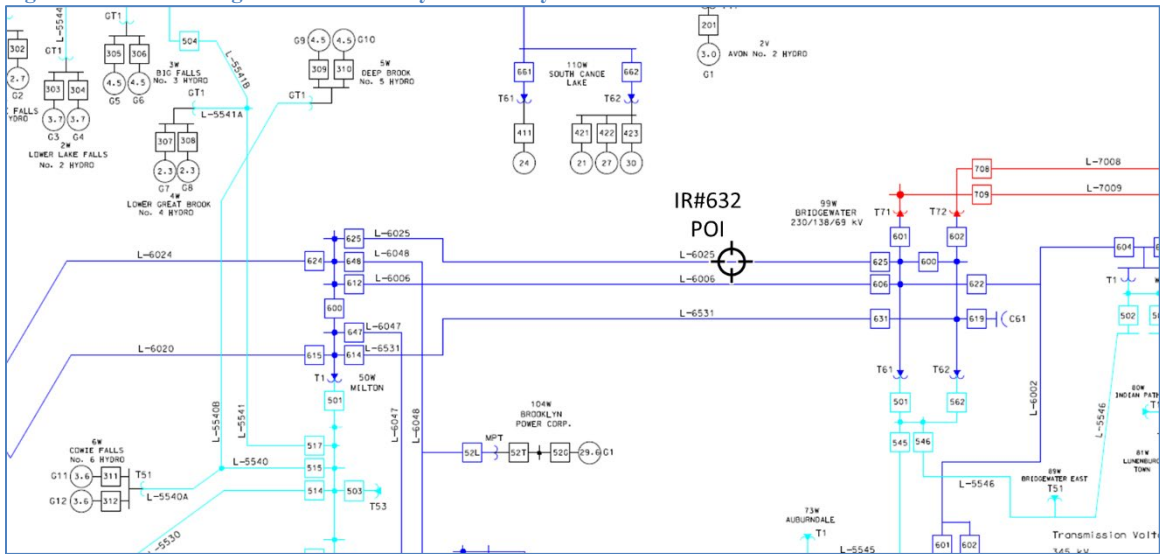

Figure 3 Circuit Configuration in Vicinity of Primary and Alternate POI



2 Scope

The objective of this Interconnection Feasibility Study (FEAS) is to provide a preliminary evaluation of system impacts from interconnecting the proposed generation facility to the NSPI transmission system at the requested location. The assessment will identify potential impacts on transmission element loading, which must remain within their thermal limits. Any potential violations of voltage criteria will be identified and addressed. If the proposed generation increases the short-circuit duty of any existing circuit breakers beyond their rated capacity, the circuit breakers must be upgraded. Single contingency criteria are applied.

In accordance with Section 6.1 of the Generator Interconnection procedures (GIP), the alternate POI is only studied if the FEAS uncovers unexpected results not contemplated during the Scoping Meeting.

The scope of the FEAS includes the modelling of the power system in normal state (with all transmission elements in service) under anticipated load and generation dispatch conditions. A power flow and short circuit analysis is performed to provide the following information:

- Preliminary identification of any circuit breaker short circuit capability limits exceeded as a result of the interconnection, and any network upgrades necessary to address the short circuit issues associated with IR#632. Expected minimum short circuit capability will also be identified for the purposes of Short Circuit Ratio analysis.
- Preliminary identification of any thermal overload or voltage limit violations resulting from the interconnection and identification of the necessary network upgrades to allow full output of the proposed facility. Thermal limits are applied to the seasonal (summer/winter) emergency ratings of transmission elements. Voltage violations occur when the post-contingency transmission bus voltage is outside the range of +/-10% of nominal voltage.
- Preliminary analysis of the ability of the proposed Interconnection Facility to meet the reactive power, power quality and cold-weather capability requirements of the NSPI *Transmission System Interconnection Requirements*¹.
- Preliminary description and high-level non-binding estimated cost and time to construct the facilities required to interconnect the generating facility to the transmission system.
- For comparative purposes, the impact of IC#632 on incremental system losses under standardized operating conditions is examined.

¹ [transmission-system-interconnection-requirements\(nspower.ca\)](http://transmission-system-interconnection-requirements(nspower.ca))

This FEAS is based on a power flow and short circuit analysis and does not include a complete determination of facility changes/additions required to increase the system transfer capabilities that may be required to meet the design and operating criteria established by NSPI, the Northeast Power Coordinating Council (NPCC), and the North American Electric Reliability Corporation (NERC). These requirements will be determined by a more detailed analysis in the subsequent interconnection System Impact Study (SIS). An Interconnection Facilities Study (FAC) follows the SIS to ascertain the final cost estimate to the interconnect the generating facility.

The ERIS study identifies necessary upgrades to allow full output of the proposed Generating Facility and the maximum allowed output, at the time the study is performed, of the interconnecting Generating Facility without requiring additional Network Upgrades.

3 Assumptions

This FEAS is based on the technical information provided by the Interconnection Customer. The Point of Interconnection (POI) and configuration is studied as follows:

1. NRIS and ERIS per section 3.2 of the GIP.
2. Commercial Operation date 2023-12-31.
3. The Interconnection Customer Interconnection Facility (ICIF) consists of 16 Wind Energy Converter System (WECS) units; Vestas V162, 6.0 MW, 720V, Type 4 (FSCS full converter model), capped at a total of 96 MW, connected to three collector circuits operating at a voltage of 34.5kV.
4. Although the IC proposed a three-breaker ring bus at the proposed POI on L-6025, this line is currently non-Bulk Power System at 138kV and therefore in accordance with Table 8 of the NSPI *Transmission System Interconnection Requirements* the tap point will be a “direct line tap with Transfer Trip protection”. It is assumed that the ICIF will include a circuit breaker to protect the IC substation step-up transformer and form part of the revised line protection scheme for L-6025.
5. The generation technology used must meet NSPI requirements for reactive power capability of at least 0.95 capacitive to 0.95 inductive at the HV terminals of the IC substation step-up transformer. It is also required to have high-speed Automatic Voltage Regulation to maintain constant voltage at the designated voltage control point during and following system disturbances as determined in the subsequent System Impact Study. The designated voltage control point will either be the low voltage terminals of the wind farm transformer, or if the high voltage terminals are used, equipped with droop compensation controls. It is assumed that the generating units are not de-rated in their MW capability when delivering the required reactive power to the system.

Control Centre Operations – Interconnection Feasibility Study Report

6. Preliminary data was provided by the IC for the IC substation step-up transformer, consisting of one 138kV/34.5kV 66/88/110 MVA station transformer. The substation step-up transformer was modeled with a positive-sequence impedance of 7.0% on 66 MVA with an X/R ratio of 22. The IC indicated that this Interconnection Facility step-up transformer has a grounded wye-delta-wye winding configuration with +/-10% fixed (off-load) tap changer in (assumed) 8 steps. The impedance of each generator step-up transformer was given as 9.9% on 7.0 MVA with an assumed X/R ratio of 11.
7. Detailed collector circuit data was not provided, so typical data ($R+jX = 0.01+j0.04$ p.u. on 100 MVA) was assumed with the understanding that the net real and reactive power output of the plant will be impacted by losses through transformers and collector circuits.
8. The FEAS analysis is based on the assumption that IR's higher in the Generation Interconnection Queue and OATT Transmission Service Queue that have completed a System Impact Study, or that have a System Impact Study in progress will proceed, as listed in Section 4 below.
9. Although the Interconnection Request document indicated the winter rating is based on an ambient temperature of 0°C, is assumed that the wind turbines are equipped with a “cold weather option” suitable for delivering full power under expected Nova Scotia winter environmental conditions of -30°C as per the NSPI *Transmission System Interconnection Requirements*.
10. Planning criteria meeting NERC Standard TPL-001-4 *Transmission System Planning Performance Requirements* and NPCC Directory 1 *Design and Operation of the Bulk Power System* as approved for use in Nova Scotia by the Utility and Review Board, are used in evaluation of the impact of any facility on the Bulk Electric System.
11. The rating of transmission lines in the vicinity of IR#632 are shown in Table 1.

Line	Conductor	Design Temp	Limiting Element	Summer Rating Normal/Emergency	Winter Rating Normal/Emergency
L-7008	1113 Beaumont	70°C	CT Ratio	398/438 MVA	398/438 MVA
L-7009	795 Drake	50°C	Conductor	223/245 MVA	340/374 MVA
L-6002	556.5 Dove	50°C	Cond/Switch	110/121 MVA	143/157 MVA
L-6006	795 Drake	50°C	Conductor	135/149 MVA	205/225 MVA
L-6025	1113 Beaumont	70°C	CT Ratio	200/220 MVA	200/220 MVA
L-6531	556.5 Dove	50°C	Conductor	110/121 MVA	165/181 MVA
L-6021	336.4 Linnet	50°C	Switch	72/79 MVA	72/79 MVA
L-6020	336.4 Linnet	50°C	Conductor	82/90 MVA	121/133 MVA
L-6024	795 Drake	50°C	Switch	72/79 MVA	72/79 MVA
L-5535	2/0 Quail	50°C	Conductor	23/25 MVA	34/37 MVA
L-5532	4/0 Penguin/Quail	50°C	Conductor	23/25 MVA	34/37 MVA

4 Projects with Higher Queue Positions

All in-service generation is included in the FEAS, except for Lingan Unit 2, which is assumed to be retired.

As of 2022-01-10, the following projects are higher queued in the Advanced Stage Interconnection Request Queue and are committed to the study base cases:

- IR426: GIA executed
- IR516: GIA executed
- IR540: GIA executed
- IR542: GIA executed
- IR574: GIA in progress
- IR598: FAC in progress

The following project has been submitted to the Transmission Service Request (TSR) Queue:

- TSR411: SIS in progress

Preceding IR#632 are six transmission and three distribution Interconnection Requests with GIA's executed. A long-term firm point-to-point transmission service reservation in the amount of 550 MW from New Brunswick to Nova Scotia (TSR-411). This transmission service request is expected to be in service in 2025 and system studies are currently underway to determine the required upgrades to the Nova Scotia transmission system. As a result, the following notice has been posted to the OASIS site at <https://www.nspower.ca/oasis/generation-interconnection-procedures>:

Effective January 19th, 2021, please be advised that the completion of advanced-stage Interconnection Studies under the Standard Generator Interconnection Procedures (GIP) may be delayed pending the outcome of the Transmission Service Request (TSR) 411 System Impact Study, which is expected to identify significant changes to the NSPI transmission system. The revised expected completion date for the study is February 28, 2022. Feasibility Studies initiated prior to the completion of the TSR System Impact Study will be performed based on the current system configuration.

5 Short-Circuit Duty / Short Circuit Ratio

The maximum (design) expected short-circuit level is 5,000 MVA (21 kA) on 138kV systems and 10,000 MVA (25 kA) on 230kV systems. The fault current characteristic for

the Vestas V162 – 6 MW fully converted units is given as 1.2 times rated current, or $X'd = 0.8$ per unit.

Short circuit analysis was performed using PSS®E for a classical fault study, 3LG and flat voltage profile at 1.0 p.u. V. The short-circuit levels in the area before and after this development are provided below in Table 2 (L-6025 POI).

Table 2: Short-Circuit Levels. IR#632 on L-6025 Three-phase MVA ⁽¹⁾		
Location	Without IR#632	With IR#632
All transmission facilities in service		
Interconnection Facility (138kV)	1148	1241
50W-Milton (138kV)	1255	1319
99W-Bridgewater (138kV)	1638	1720
Minimum Conditions (PA1, LG1, ML In-Service)		
Interconnection Facility (138kV), all lines in-service	708	801
Interconnection Facility (138kV), L-6025 open at 50W	631	724
Interconnection Facility (138kV), L-6025 open at 99W	483	576

(1) Classical fault study, flat voltage profile

The interrupting capability of the 138kV circuit breakers is at least 3500 MVA at 50W and 6000 MVA at 99W. As such, the interrupting ratings at these substations will not be exceeded by this development on its own.

Vestas documentation has indicated that the minimum Short Circuit Ratio of the Vestas V162-6 MW WECS is 5. Based on the calculated short circuit levels, a POI on L-6025, and a 96 MW installation consisting of 16 units each 6 MVA, the minimum short circuit ratio would be 7.4 at the HV terminals of the IR#632 substation with all lines in service and IR#632 off line. This falls to 5.0 with L-6025 open at 99W-Bridgewater, and 6.6 if L-6025 is open at 50W-Milton.

6 Voltage Flicker and Harmonics

Flicker coefficient information was not provided for the Vestas V162 – 6 MW Wind Turbines, however, it is known that Type 4 wind turbines typically have a flicker coefficient of 2.0 - 2.4 at angle of 85°, which is about half that of Type 3 machines. Type 4 wind turbines are not expected to result in appreciable voltage flicker at minimum generation conditions. Voltage flicker will be further examined when data for the 6.0 MW Vestas V162 machine is made available for the SIS.

The generator is expected to meet IEEE Standard 519-2014 limiting voltage Total Harmonic Distortion (all frequencies) to a maximum of 1.5%, with no individual harmonic exceeding 1.5% on 138kV.

7 Load Flow Analysis

The load flow analysis was completed for generation dispatches under winter peak load conditions, summer low-hydro and spring high-hydro load conditions expected to stress transfers in western NS and Annapolis Valley.

Figure 4 shows the relevant interfaces on the NSPI transmission system.

Figure 4 Relevant Transmission Interfaces

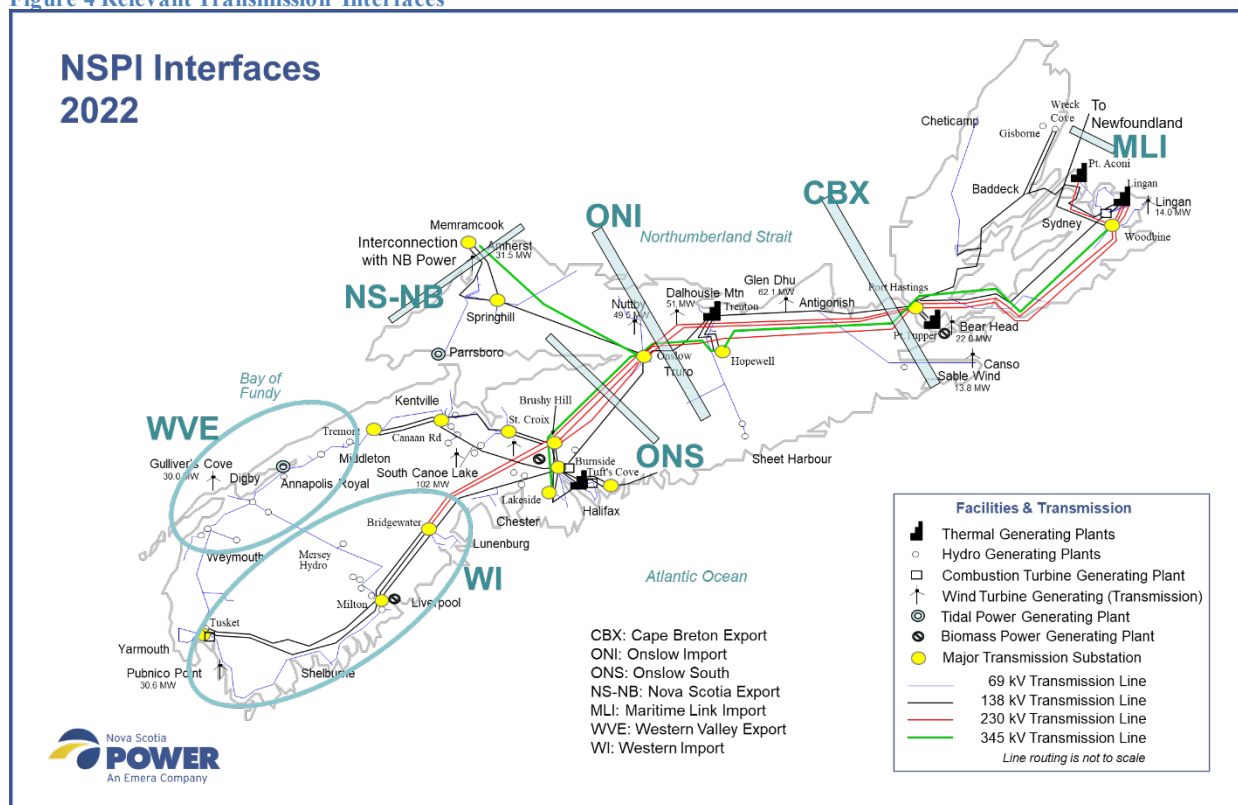

Transmission connected wind generation facilities were typically dispatched at approximately 40%, except in the vicinity of IR#632. There is high correlation between wind plants in western NS between Digby, Yarmouth and Halifax, so it is reasonable to expect that these other wind plants would be near full output when IR#632 is at rated output.

Control Centre Operations – Interconnection Feasibility Study Report

The Western region of Nova Scotia is sensitive to the balance between local load and hydro/wind generation. Hydro plants are likely to be at rated output during spring run-off conditions and are less likely to be so during the drier summer and fall months. The 10W-Tusket Gas Turbine plays an important role in ten-minute operating reserve which can be called upon at any time, so transmission capacity in the vicinity of IR#631 takes this into consideration.

The cases and dispatch scenarios considered are shown in Table 3.

Case	NS-NB	LOAD	HYDRO	ONS	WVE	WI	MER	IR#632	Wind
SP01-1	335	1350	20	562	-30	96	9	0	186
SP01-2	335	1350	20	467	-30	2	9	96	282
SP02-1	0	890	140	327	56	12	43	0	161
SP02-2	0	890	140	234	56	-80	43	96	257
SP03-1	330	1350	20	562	-30	96	9	0	186
SP03-2	330	1350	20	467	-30	2	9	96	282
W01-1	180	2200	124	840	-17	162	20	0	232
W01-2	180	2200	124	744	-17	67	20	96	420

S – Summer/Spring W - Winter Peak; MER – Mersey Hydro; LOAD – Excludes PHP

For both NRIS and ERIS analysis, this FEAS added IR#632 and displaced an equivalent amount of coal-fired generation in Cape Breton. Single contingencies were applied at the 230kV, 138kV, and 69 kV voltage levels for the above system conditions with IR#632 interconnected to the POI on L-6025. Automated analysis searched for violations of emergency thermal ratings and emergency voltage limits for each contingency. Contingencies studied are listed in Table 4. It should be noted that a number of existing contingencies unrelated to IR#631 can result in the separation of the western transmission system and possible disconnection of IR#632.

Transmission Line	Transformer / Bus	Circuit Breaker Failure	Double Circuit Tower
L-7008, L-7009	120H: T71, T72	120H: 715, 716, 712, 713	L-7008 + L-7009
L-6025, L-6006, L-6531	99W: B61, B62	99W: 600	
L-6024, L-6020, L-6021	50W: B2, B3, B4, T1	5W: 600	
L-5035	9W: B52 B53		
L-5025, L-5026	51V: B51, B62	1N: 600, 613	

NRIS Results

The most significant contingency resulting in thermal overload was loss of bus 99W-B61, which would result in overload of L-6531 in case SP02-2 (high hydro dispatch). Loss of 99W-B61 opens lines L-6006 and L-6025 at the 99W-Bridgewater end, leaving IR#632 connected to 50W-Milton and flow on L-6531 at 129% of its summer emergency thermal limit. This same condition would exist for loss of the transformer 99W-T61 or several breaker-failure contingencies at 99W-Bridgewater: 99W-501, 99W-601, 99W-606.

The following options were examined:

1. Increase the operating temperature of L-6531 from 50°C to 70°C at an estimated cost of \$6,150,000 plus 10% contingency.
2. Move L-6006 from bus 99W-B61 to 99W-B62. This would involve protection and control changes at 99W-Bridgewater and a line swap at 50W-Milton, estimated at \$1,500,000.
3. Ensure that any protection operation of breaker 99W-625 transfer-trips to the remote ends 50W-625 and IR#632. Considering the fact that line protection for L-6025 must be changed, this feature can be incorporated within the expected Network Upgrades.

No contingencies resulted in a violation of voltage limit criteria under the assumption that the existing contingencies which result in western separation are excluded.

Because L-6006 and L-6025 share common buses at 99W-Bridgewater and 50W-Milton, there would be no advantage to using the alternate POI on L-6006.

ERIS Results

To avoid the thermal limit violations encountered in the NRIS analysis, IR#632 could operate at up to 55 MW without the need for transmission limit upgrades. This limitation would be expected to apply for up to 40 hours per year, during spring run-off. This would be in addition to any other system conditions that require curtailment of wind energy resources.

8 Reactive Power and Voltage Control

In accordance with the *Transmission System Interconnection Requirements* Section 7.6.2, IR#632 must be capable of delivering reactive power at a net power factor of at least +/- 0.95 of rated capacity to the high side of the plant interconnection transformer. Reactive power can be provided by the asynchronous generator or by continually acting auxiliary devices such as STATCOM, DSTATCOM or synchronous condenser, supplied by the Interconnection Customer. Rated reactive power shall be available through the full range of real power output of the Generating Facility, from zero to full power. Based on the plant rating of 96 MW, this translates into a reactive capability of 31 Mvar leading and lagging.

The information provided by the IC indicates that the Vestas V162 – 6 MW WECS have a rated power factor of 0.914 lagging and 0.949 leading at a terminal voltage of 1.0 p.u. This translates into a gross reactive power range of -31.9 Mvar to +42.6 Mvar. At 1.05 p.u. voltage, the reactive capability is +43.8 and at 1.1 p.u. voltage the capability is 44.9 Mvar. Figure 5 shows how reactive capability varies with voltage and real power output. It is noted that this unit is capable of reactive power control down to zero MW.

Figure 5: WECS Reactive Capability

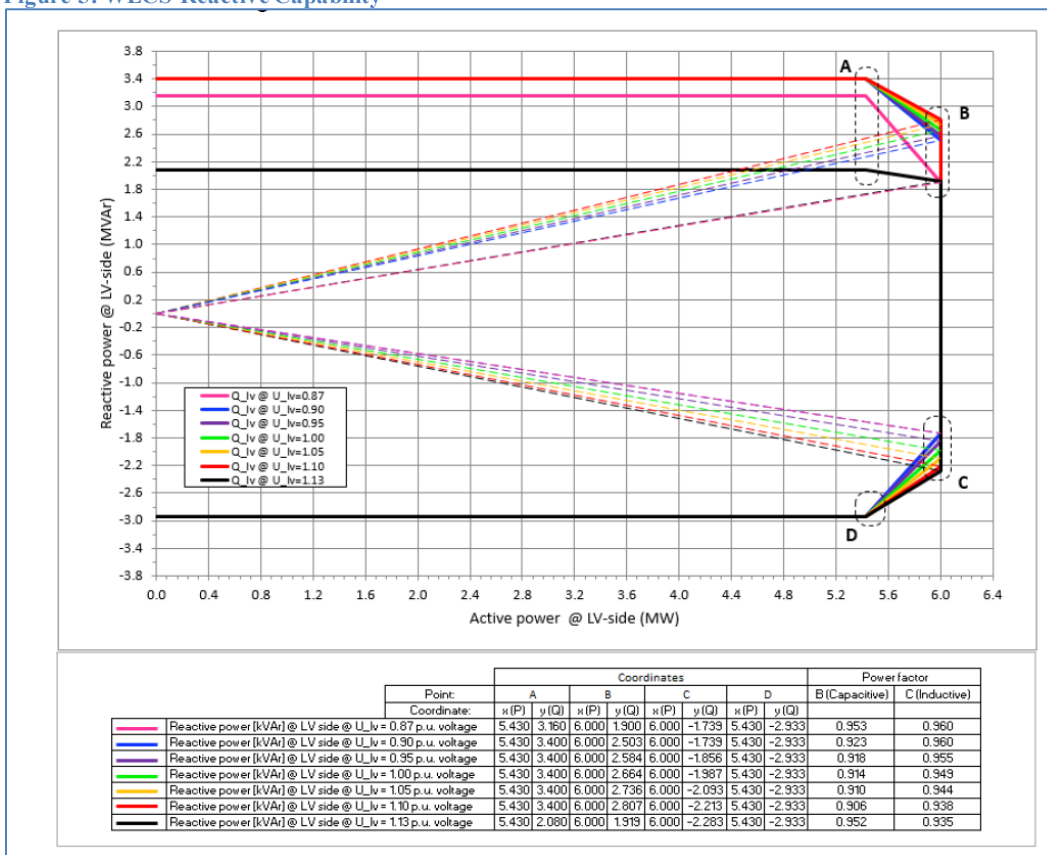

Analysis shown in Figure 6 shows that IR#632 may not be able to meet this requirement without additional reactive support. The model shows that with 16 WECS units operating at a total 96 MW and 42.6 Mvar at terminal voltage of 1.05 p.u., the delivered power to the high side of the ICIF transformer is 93.7 MW and 19.4 Mvar, or a power factor of 0.979. To meet the requirement of 0.95, a capacitor bank rated at 11 Mvar (or equivalent) would be required on the low voltage side of the ICIF transformer.

This configuration would be able to meet the leading power factor requirement while WECS are operating at 96 MW and -6 Mvar at a terminal voltage of 0.95 p.u. with the capacitor bank switched off.

Figure 6: Power Factor Analysis

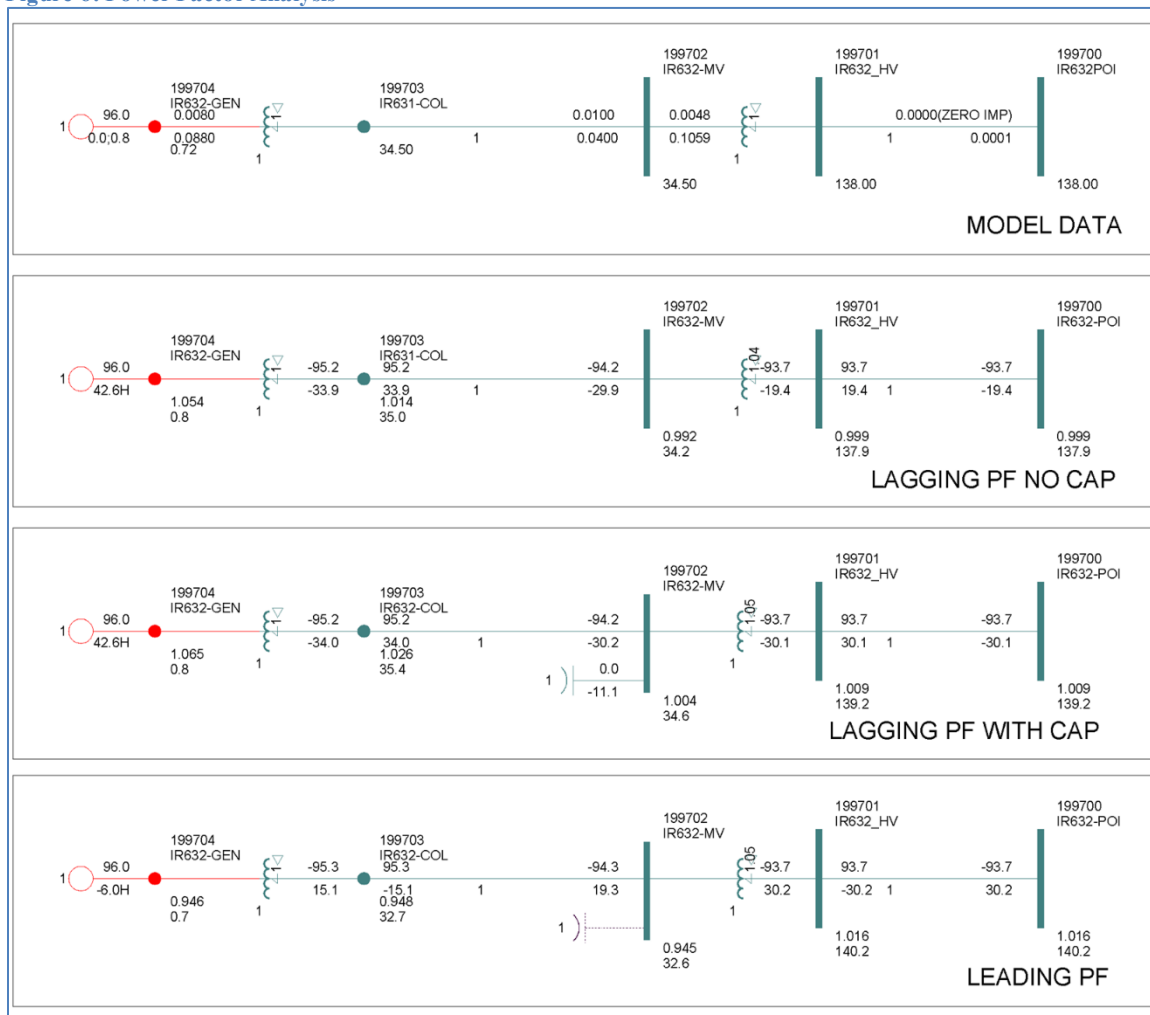

Power factor behaviour is the same regardless of the POI on L-6025 or L-6006. Because this analysis is based on preliminary transformer data and assumed collector circuit models, the size of the auxiliary reactive support will be confirmed in the SIS.

A centralized controller will be required which continuously adjusts individual generator reactive power output within the plant capability limits and regulates the voltage at the 34.5 kV bus voltage. The voltage controls must be responsive to voltage deviations at the terminals of the Interconnection Facility substation; be equipped with a voltage set-point control; and also have the ability to slowly adjust the set-point over several (5-10) minutes to maintain reactive power within the individual generators capabilities. The details of the specific control features, control strategy and settings will be reviewed and addressed in the SIS, as will the dynamic performance of the generator and its excitation. Line drop compensation, voltage droop, control of separate switched capacitor banks must be provided.

The NSPI System Operator must have manual and remote control of the voltage set-point and the reactive set-point of this facility to coordinate reactive power dispatch requirements.

This facility must also have low voltage ride-through capability as per Appendix G of the Standard Generator Interconnection and Operating Agreement (GIA). The SIS will state specific options, controls and additional facilities that are required to achieve this.

Settings for the ICIF on-load tap-changer must be coordinated with plant voltage controller for long-term reactive power and voltage management at the POI.

9 System Security / Bulk Power Analysis

Presently the 138kV buses at the 50W-Milton and the 99W-Bridgewater substations are not part of the Nova Scotia Bulk Power System (BPS) and will be further evaluated during the SIS phase. However, since IR#632 has dispersed generation totalling more than 75 MVA, Inclusion I4 of the NERC BES Definition would apply, and each generator would be classified as a BES element. The 34.5 kV bus and the 138kV bus would also be considered BES. There is the potential for an exclusion from BES to be granted for the high side (138kV) bus based on further analysis per the NS BES Exception Procedure. This analysis will be initiated as part of the System Impact Study (SIS) and exclusion from BES will only be granted upon subsequent approval by the Nova Scotia Utility and Review Board.

10 Loss Factor

Loss factor is calculated by running the winter peak load flow case with and without the new facility in service while keeping 91H-Tufts Cove as the Nova Scotia Area Interchange bus. This methodology reflects the load centre in and around Metro.

Without IR#632 in service, losses in the winter peak case total 86.2 MW. With IR#632 in service at the POI of L-6025, displacing generation at 91H, and not including losses associated with the IR#632 Generation Facilities or TPIF Interconnection Facilities, system losses total 86.4 MW, an increase of 0.2 MW. The model shows power delivered to the POI is 94.1 MW, therefore the loss factor is calculated as $0.2/94.1 = +0.2\%$.

11 Expected Facilities Required for Interconnection

The alternate POI L-6006 was not examined since the primary POI on L-6025 did not exhibit problems not foreseen in the project launching meeting.

The following facility changes will be required to connect IR#632 to the NSPI transmission system at a POI on L-6025:

11.1 NRIS Requirements:

a. Required Network Upgrades

- Modification of NSPI protection systems on L-6025 at 99W-Bridgewater and 50W-Milton including the addition of a transfer trip to breaker 50W-625 for any operation of breaker 99W-625. This may require a current differential protection scheme.

b. Required Transmission Provider’s Interconnection Facilities (TPIF):

- Add control and communications between the wind farm and NSPI SCADA system (to be specified).
- Add transmission line tap at POI including a remote controllable line tap disconnect device (motorized switch or circuit switcher) between L-6025 and the ICIF circuit breaker.

c. Required Interconnection Customer’s Interconnection Facilities (ICIF)

- 138kV circuit breaker between the TPIF line tap disconnect device and the ICIF station transformer.
- Facilities to provide 0.95 leading and lagging power factor when delivering rated output at the HV terminals of the IC Substation Step Up Transformer when the voltage at that point is operating between 95% and 105% of nominal. This FEAS analysis indicated that an 11 Mvar capacitor bank on the 34.5kV bus would provide this capability, subject to further analysis with detailed collector circuit and transformer data.
- Centralized controls. These will provide centralized voltage set-point controls and are known as Farm Control Units (FCU). The FCU will control the 34.5 kV bus voltage and the reactive output of the machines. Responsive (fast-acting) controls are required. The controls will also include a curtailment scheme which will limit or reduce total output from the facility, upon receipt of a telemetered signal from NSPI’s SCADA system.
- NSPI will have control and monitoring of reactive output of this facility, via the centralized controller. This will permit the NSPI Operator to raise or lower the voltage set-point remotely.

- Low voltage ride-through capability per Section 7.4.1 of the Nova Scotia Power Transmission System Interconnection Requirements.
- Real-time monitoring (including an RTU) of the interconnection facilities. Local wind speed and direction, MW and Mvar, as well as bus voltages are required.
- Facilities for NSPI to execute high speed rejection of generation (transfer trip) if determined in SIS. The plant may be incorporated into RAS run-back schemes.
- Synthesized inertia (Fast Frequency Response) controls within the WECS.
- Automatic Generation Control to assist with tie-line regulation.
- Operation at ambient temperature of -30°C, contrary to the reported 0°C value provided on the Interconnection Request.

11.2 ERIS Requirements:

The facility requirements for ERIS are the same as NRIS, with the exception that IR#632 could be limited to 55 MW during certain system conditions as an alternative to providing the transfer-trip line protection modification to L-6025 for operation of breaker 99W-625.

12 NSPI Interconnection Facilities and Network Upgrades Cost Estimate

Estimates for NSPI Interconnections Facilities and Network Upgrades for interconnecting 96 MW wind energy at the 138kV POI at on L-6025 are included in Table 5 (NRIS) and Table 6 (ERIS).

Table 5 Cost Estimate NRIS @ POI L-6025		
Item	Network Upgrades	Estimate
1	P&C modifications to L-6025 at 50W-Milton and 99W-Bridgewater.	\$500,000
2	Transfer trip scheme to 50W-625 for any operation of breaker 99W-625	\$100,000
	Sub-total for Network Upgrades	\$600,000
Item	TPIF Upgrades	Estimate
1	Direct line tap (no breaker)	\$500,000
2	NSPI P&C relaying equipment	\$100,000
3	NSPI supplied RTU	\$60,000
4	Tele-protection and SCADA communications	\$150,000
	Sub-total for TPIF Upgrades	\$810,000

Control Centre Operations – Interconnection Feasibility Study Report

	Total Upgrades	Estimate
	Network Upgrades + TPIF Upgrades	\$1,410,000
	Contingency (10%)	\$141,000
	Total (Incl. 10% contingency and Excl. HST)	\$1,551,000

Table 6 Cost Estimate ERIS @ POI L-6025		
Item	Network Upgrades	Estimate
1	P&C modifications to L-6025 at 50W-Milton and 99W-Bridgewater.	\$500,000
	Sub-total for Network Upgrades	\$500,000
Item	TPIF Upgrades	Estimate
1	Direct line tap (no breaker)	\$500,000
1	NSPI P&C relaying equipment	\$100,000
2	NSPI supplied RTU	\$60,000
3	Tele-protection and SCADA communications	\$150,000
	Sub-total for TPIF Upgrades	\$810,000
	Total Upgrades	Estimate
	Network Upgrades + TPIF Upgrades	\$1,310,000
	Contingency (10%)	\$131,000
	Total (Incl. 10% contingency and Excl. HST)	\$1,441,000

The preliminary non-binding cost estimate for interconnecting 96 MW at the POI at L-6025 under NRIS is \$1,551,000 including a contingency of 10%. Of this amount, \$660,000 is for Network Upgrades, which are funded by the IC, but are eligible for refund under the terms of the GIA. The remainder of the costs are fully funded by the IC.

The preliminary non-binding cost estimate for interconnecting 96 MW at the POI at L-6025 under ERIS is \$1,441,000 including a contingency of 10%. Of this amount, \$550,000 is for Network Upgrades, which are funded by the IC, but are eligible for refund under the terms of the GIA. The remainder of the costs are fully funded by the IC. Under ERIS, IR#632 may be limited to 55 MW under certain operating conditions, estimated to be up to 40 hours per year.

These estimates do not include potential additional costs to address any stability issues identified at the SIS stage based on dynamic analysis.

Because the analysis did not uncover any unexpected issues, only the costs associated with the POI on L-6025 are provided.

The estimated time to construct the Transmission providers Interconnection Facilities is 18-24 months after receipt of funds and cleared right of way from the IC.

13 Issues to be addressed in SIS

The following provides a preliminary scope of work for the subsequent SIS for IR#632. The SIS will include a more comprehensive assessment of the technical issues and requirements to interconnect generation as requested. It will include contingency analysis, system stability, ride through, and operation following a contingency (N-1 operation). The SIS must determine the facilities required to operate this facility at full capacity, withstand any contingencies (as defined by the criteria appropriate to the location) and identify any restrictions that must be placed on the system following a first contingency loss. The SIS will confirm the options and ancillary equipment that the customer must install to control flicker, voltage, frequency response, active power and ensure that the facility has the required ride-through capability. The SIS will be conducted in accordance with the GIP with the assumption that all appropriate higher-queued projects proceed, and the facilities associated with those projects are installed.

The following outline provides the minimum scope that must be complete in order to assess the impacts. It is recognized the actual scope may deviate, to achieve the primary objectives.

The assessment will consider but not be limited to the following.

- i. Facilities that the customer must install to meet the requirements of the GIP and the NSPI *Transmission System Interconnection Requirements*.
- ii. The minimum transmission additions/upgrades that are necessary to permit operation of this Generating Facility, under all dispatch conditions, catering to the first contingencies listed.
- iii. Guidelines and restrictions applicable to first contingency operation (curtailments etc.).
- iv. Under-frequency load shedding impacts.

To complete this assessment the following first contingencies, as a minimum, will be assessed:

- L-8001
- L-8002
- L-7008
- L-7009
- Simultaneous loss of L-7008 + L-7009

Control Centre Operations – Interconnection Feasibility Study Report

- Buses at 50W and 99W
- Transformer 99W-T61
- Loss of largest generation source in NS
- Loss of Maritime Link

To complete this assessment the dynamics of the following first contingencies, as a minimum, will be assessed:

- 3 phase fault L-8001 with high NS import from NB (islanding)
- 3 phase fault L-8002 at 67N-Onslow
- Simultaneous SLG on L-7008 & L-7009 double circuit tower at 120H-Brushy Hill
- SLG fault on breaker 99W-600 or 50W-600, with load loss
- 3 phase fault on transformer 99W-T61

Any changes to RAS schemes required for operation of this generating facility, in addition to existing generation and facilities that can proceed before this project, will be determined by the SIS as well as any required additional transmission facilities. The determination will be based on NERC² and NPCC³ criteria as well as NSPI guidelines and good utility practice. The SIS will also determine the contingencies for which this facility must be curtailed.

Nova Scotia Power
Transmission System Operations
2022-03-01

² NPCC criteria are set forth in its Reliability Reference Directory #1 *Design and Operation of the Bulk Power System*

³ NERC transmission criteria are set forth in *NERC Reliability Standard TPL-001-4*