



Facilities Study Report

IR-618

**130.5 MW Goose Harbour Lake Wind
Guysborough County, NS**

Prepared by
Tim Leopold, P.Eng.

August 31, 2023

Facilities Study Report

IR-618 - Goose Harbour Lake Wind



EXECUTIVE SUMMARY

This project (IR#618 – Goose Harbour Lake Wind) provides for the establishment of a 230 kV system interconnection to Nova Scotia Power Inc (NSPI) transmission line L-7003 for a 130.5MW Wind Generation Facility in Guysborough County, Nova Scotia.

The Point of Interconnection (POI) is at the 230kV bus node of the new 230kV three-breaker ring substation (125C-Grosvenor) located approximately 11.8 kms from 3C-Port Hastings substation (between existing line structures L7003-696 and L7003-697). The Point of Change of Ownership (PCO) is at the new 230kV line (L-7025) terminal structure at the Goose Harbour Lake Wind Interconnection Facility substation 126C. The POI and PCO are further clarified in the Interconnection Overview Drawing provided in Appendix B.

The new 230kV system interconnection substation has been assigned NSPI system number 125C – Grosvenor. The interconnection substation at Goose Harbour Lake Wind facility has been assigned system number 126C – Goose Harbour Lake Wind, and the new transmission line between the interconnection substation 125C and Goose Harbour Lake Wind substation 126C has been assigned system number L-7025.

The scope of work associated with this interconnection will consist of a line tap arrangement to NSPI transmission line L-7003, a three-breaker ring interconnection substation at 125C-Grosvenor, a new 2.1km 230kV transmission line (L-7025) from the interconnection substation 125C to the Goose Harbour Lake Wind facility (126C), modifications to existing remote protection and remedial action schemes (RAS) and the provision of redundant telecommunications systems.

All interconnection facilities must meet NSPI's Transmission System Interconnection Requirements (TSIR) as published on the NSPI OASIS site.

The interconnection substation and the Interconnection Customer's Facility substation both meet the Bulk Power System criteria and shall be designed with redundant and physically separated protection, control, and communications.

The following scope of work has been identified as meeting the defined criteria for 'Stand Alone' upgrades as per section 2.10:

- The interconnection substation (125C-Grosvenor) including land acquisition, site preparation, access road, foundations, site grounding, primary equipment, control building, protection and control panels, and all associated devices except for the telecommunications equipment and the microwave radio tower.
- The transmission line L-7025 from 125C-Grosvenor to 126C-Goose Harbour Lake Wind substation including easement acquisition, access routes, all structures, conductors, shield wires, insulators, and foundations, the optical fibre shield wire, line terminations at both substations, and all potential railway, highway, and water crossings.
- All elements of the Goose Harbour Lake Wind Interconnection Facility substation 126C except for provision of the revenue meter, the required L-7025 protection and control equipment, the remote terminal unit (RTU), and the telecommunications equipment required at 126C-Goose Harbour Lake Wind substation.

Non-stand-alone upgrades include all other elements of the scope of work not identified as stand-alone upgrades including:

- The 230kV transmission line tap at 125C-Grosvenor to L-7003
- The remote protection modifications at 3C-Port Hastings

Facilities Study Report

IR-618 - Goose Harbour Lake Wind



- The modifications to existing Remedial Actions Schemes (RAS).
- Telecommunications equipment supply and installation at 125C-Grosvenor Substation.
- The revenue meter, L-7025 protection and control equipment, remote terminal unit (RTU), and telecommunications equipment required at 126C-Goose Harbour Lake Wind substation.

L-7003 shares a transmission line corridor with L-7004, and L-6515. Outages to these lines impose limitations on Cape Breton export energy flows. These constraints will require NSPI System Operator actions to minimize risks and maintain system stability. All system outages required to complete the interconnection work shall require advanced planning and coordination with the NS System Operator.

The Revenue Class 230kV voltage and current transformers required for revenue metering shall be supplied and installed by the Interconnection Customer as per NSPI specification.

NSPI will require space and unrestricted access in the Interconnection Customer's substation (126C) control building for the L-7025 line protection equipment, the Remote Terminal Unit (RTU) and the communications equipment.

The total estimated cost to construct the required Network Upgrades and Transmission Provider's Interconnection Facilities is **\$15,065,913**. Of this amount, the estimated cost to construct the 'Stand-Alone' Network Upgrades and Transmission Provider's Interconnection Facilities is **\$11,543,486** and the estimated cost to construct the 'Non-Stand-Alone' Network Upgrades and Transmission Provider's Interconnection Facilities is **\$3,522,427**. The detailed cost estimates are provided in Appendix F. All cost estimates exclude allowance for funds used during construction (AFUDC) or any escalations due to timing of project execution. The customer will be responsible for paying NSPI for the actual costs associated with this project, be they higher or lower than the estimate provided herein, unless otherwise specified in the Generation Interconnection Agreement (GIA).

The Interconnection Customer's targeted commercial operation date is December 2025 with first-power available in Q3, 2025. An overall preliminary project schedule is provided in Appendix G.

Facilities Study Report

IR-618 - Goose Harbour Lake Wind



Table of Contents

EXECUTIVE SUMMARY	II
1.0 INTRODUCTION	1
1.1 PROJECT OWNERSHIP AND RESPONSIBILITIES.....	1
1.2 ESTIMATED COST.....	2
1.3 PROJECT SCHEDULE	2
2.0 SCOPE OF WORK	3
2.1 INTERCONNECTION OVERVIEW.....	3
2.2 LINE TAP ON TRANSMISSION LINE L-7003	3
2.3 TRANSMISSION INTERCONNECTION SUBSTATION:125C-GROSVENOR	3
2.4 NEW 230kV TRANSMISSION LINE L-7025	11
2.5 REMEDIAL ACTION SCHEME (RAS) MODIFICATIONS	11
2.6 GOOSE HARBOUR LAKE TERMINAL STATION (126C).....	11
2.7 REMOTE TERMINAL PROTECTION MODIFICATIONS	15
2.8 REVENUE METERING	15
2.9 TELECOMMUNICATIONS	16
2.10 STAND ALONE UPGRADES CATEGORIZATION.....	16
3.0 PERMITS, APPROVALS, AND STANDARDS	18
4.0 DESIGN AND CONSTRUCTION	19
5.0 SCHEDULE MILESTONES	20
6.0 COST ESTIMATE	21
7.0 COMMISSIONING/OPERATIONS	22
APPENDIX A – INTERCONNECTION FACILITIES STUDY AGREEMENT	24
APPENDIX B – INTERCONNECTION OVERVIEW	25
APPENDIX C – INTERCONNECTION SUBSTATION DEVELOPMENTAL ONE LINE	26
APPENDIX D – INTERCONNECTION SUBSTATION DEVELOPMENTAL PLAN VIEW	27
APPENDIX E – INTERCONNECTION SUBSTATION DEVELOPMENTAL OVERALL PLAN	28
APPENDIX F – COST ESTIMATE DETAILS	29
APPENDIX G – PRELIMINARY PROJECT SCHEDULE	31
APPENDIX H – REVENUE METERING	32
APPENDIX I – 126C-GOOSE HARBOUR LAKE TERMINAL STATION ONE LINE	34
APPENDIX J – TRANSMISSION LINE (L-7025) BASIS OF DESIGN	35
APPENDIX K – PROPOSED TRANSMISSION LINE ROUTING FOR L-7025	36
APPENDIX L – MINUTES OF FACILITIES STUDY REVIEW MEETING	37

Facilities Study Report

IR-618 - Goose Harbour Lake Wind



1.0 INTRODUCTION

This Facilities Study Report is based on the System Impact Study Report (SIS) as identified below:

System Impact Study Report (Part 1)
Report GIP-IR618-SIS-Part1-R1
By Hung Huynh, P.Eng.
Dated August 17, 2023

The SIS describes the facilities and modifications required to the Nova Scotia transmission system to add a 130.5 MW Wind Generating Facility at Goose Harbour Lake interconnected to NSPI's 230kV transmission line L-7003. It also addresses short circuit, steady state, stability, power flow, and motor start analysis. It provides an overview of the scope of work to be completed and directions to this Facilities Study (FAC). Transmission capacity for a potential future interconnection addition of 90MW was also accounted for in the FAC.

The scope of work identified in the Facilities Study outlines the anticipated work requirements for a conceptual level of engineering and design. Detailed design may identify additional requirements or modifications that were not anticipated or captured during the preliminary design phase.

1.1 Project Ownership and Responsibilities

Ownership, maintenance, and other commercial operation arrangements will be covered separately in a Generation Interconnection Agreement (GIA) between NSPI and the Interconnection Customer.

Following NSPI system naming standards, the new interconnection substation will be labeled 125C-Grosvenor and Interconnection Customer's facility substation will be labeled 126C-Goose Harbour Lake Wind. The new 230kV transmission line from 125C-Grosvenor to 126C-Goose Harbour Lake Wind will be labeled L-7025.

Ownership of the infrastructure associated with 126C-Goose Harbour Lake Wind substation is based on the Point of Change of Ownership at L-7025 line dead-end structure at 126C-Goose Harbour Lake Wind substation (refer to the Interconnection Overview Diagram in Appendix B). NSPI, as the transmission provider, will own the new interconnection substation (125C-Grosvenor) and the new 230kV line L-7025 from the 125C-Grosvenor substation to the dead-end structure located within customer's substation 126C.

All communication systems infrastructure between NSPI's 125C-Grosvenor substation and the new Goose Harbour Lake Wind facility required for control and monitoring will be owned by NSPI. This includes the fibre and microwave radio communications equipment, protection equipment, and the Supervisory Control and Data Acquisition (SCADA) Remote Terminal Unit (RTU) located at Goose Harbour Lake Wind substation 126C.

NSPI will also own the revenue metering equipment located in the interconnection substation 126C-Goose Harbour Lake Wind.

Facilities Study Report

IR-618 - Goose Harbour Lake Wind



All interconnection facilities must meet NSPI's Transmission System Interconnection Requirements (TSIR) as published on the NSPI OASIS site as well as NPCC bulk power system facility requirements.

1.2 Estimated Cost

The total estimated cost to construct the required Network Upgrades and Transmission Provider's Interconnection Facilities is **\$15,065,913**. Of this amount, the estimated cost to construct the 'Stand-Alone' Network Upgrades and Transmission Provider's Interconnection Facilities is **\$11,543,486** and the estimated cost to construct the 'Non-Stand-Alone' Network Upgrades and Transmission Provider's Interconnection Facilities is **\$3,522,427**. The detailed cost estimates are provided in Appendix F. *All cost estimates exclude allowance for funds used during construction (AFUDC) or any escalations due to timing of project execution.*

The cost estimates are based on the scope of work outlined in Section 2.0 of this Facilities Study Report. The cost estimate provided in Appendix F are estimates only based on 2023 budgetary dollars. The customer will be responsible for paying NSPI for the actual costs associated with this project, be they higher or lower than the estimate provided herein, unless otherwise specified in the Generation Interconnection Agreement (GIA).

The cost estimate in this report is valid for one hundred eighty (180) days.

The project cannot commence until the customer delivers to NSPI the balance of the cost estimate for the project in a form acceptable to NSPI, or as per the terms of the GIA.

1.3 Project Schedule

The estimated project duration includes all scope of work required for the transmission interconnection as outlined in Section 2.0.

The Interconnection Customer's targeted commercial operation date is December 2025 with first-power available in Q3, 2025.

An outline of major project milestones is provided in Section 5.0 and a preliminary project schedule outlining the major components of this project is provided in Appendix G.

Facilities Study Report

IR-618 - Goose Harbour Lake Wind



2.0 SCOPE OF WORK

2.1 Interconnection Overview

An interconnection overview diagram of the 130.5MW Goose Harbour Lake Wind interconnection is provided in Appendix B. The Point of Interconnection (POI) is at the 230kV bus node of the new 230kV three-breaker ring substation (125C-Grosvenor) located approximately 11.8 kms from 3C-Port Hastings substation (between existing line structures L7003-696 and L7003-697). The Point of Change of Ownership (PCO) is at the new 230kV line (L-7025) terminal structure at the Goose Harbour Lake Wind Interconnection Facility substation 126C.

2.2 Line Tap on Transmission Line L-7003

A conceptual design plan for the line tap to L-7003 has been provided in Appendix E. Modifications are anticipated as detailed design is finalized. The overall design concept entails replacing structures 696 and 697 with taller poles, installing an additional dead-end structure on the west side on the line tap, installing a double dead-end structure in L-7003 between structures 696 and 697 and extending line taps under line L-7003 into substation 125C.

An outage will be required on L-7003 to facilitate installation of the line taps to the 125C Substation. Outages to L-7003 will need to be approved by the System Operator and coordinated with any planned outages to minimize any system impacts.

Estimated costs associated with the line tap on L-7003 including termination at the 125C Substation are included in the Non-Stand-Alone Network Upgrade cost estimate.

2.3 Transmission Interconnection Substation: 125C-Grosvenor

The developmental one line for 125C-Grosvenor substation is provided in Appendix C. The developmental plan view for 125C-Grosvenor substation is provided in Appendix D. In summary, the transmission scope of work includes a 230kV three-breaker ring bus substation with three 230kV line terminals including all associated protection and control, tele-communications, and site development. The Interconnection Customer shall provide NSPI with deeded ownership, and developed road access to, the land associated with the substation site.

The interconnection substation meets the NPCC Bulk Power System criteria and shall be designed with redundant and physically separated protection, control, and communications.

Facilities Study Report

IR-618 - Goose Harbour Lake Wind



2.3.1 Substation Site Development / Civil Works / Structures / Site Access

2.3.1.1 General Requirements

The following are the general requirements for NSPI substation civil design and construction:

- Topological survey is to be performed prior to design.
- Geotechnical investigation and soil resistivity testing is to be performed prior to design.
- Site Access
 - Access driveways must be designed with a adequate width such that all equipment, deliveries, and general maintenance vehicles are able to access substation site.
 - Ditching along access roads are to be provided to ensure access is dry and stable.
 - Culverts are to be used where any drainage cuts across access route.
- Erosion/Sediment Control
 - Check dams/silt fences shall be installed to intercept runoff from any ditches and dewatering activities.
 - Substation finished grade shall be chosen such that surface water drains away from the site.
 - All exposed banks and/or erodible soil shall be temporarily stabilized by suitable means (hydroseed, straw, hay, or sodding).
- Environmental
 - A 30m wide buffer zone shall bracket all watercourses (if applicable).
 - Work inside this zone requires approval through the Dept. of Environment.
- Clearing/Stripping
 - Seasonal clearing must ensure nesting season is avoided and no habitat is destroyed.
 - Stripping shall consist of the removal and disposal of all surface vegetation, chipped or mulched brush, topsoil, trees, brush, tree stumps, roots, and any deleterious other material.
 - All greenfield sites are to be stripped at a minimum depth of 300mm.
- Excavation
 - All excavation practices must adhere to NSPI specification SS –10.7 - Earthworks.
 - Slopes resulting from rock cuts shall normally be 1 horizontal to 1 vertical. Slopes shall be cleaned and trimmed of all disturbed and loose material and left in a neat condition.
 - Following excavation on the site, the ground surface shall be graded and compacted to 95% Standard Proctor Density where it is 900 mm or more from subgrade and to the 100% Standard Proctor Density within the top 900 mm from subgrade.
- Backfill
 - All backfill practices must adhere to NSPI spec SS –10.7 - Earthworks
 - No native material shall be used as fill unless specified by design engineer.
 - Standard Type 1, and 2 gravels used for backfill shall conform to the Nova Scotia Department of Transportation and Public Works Standard Specification.
- Foundations
 - Bearing capacity design shall use maximum allowable bearing pressure of 75 kPa for support structures and 120 kPa for dead end structures.
 - Foundation design shall assume unsubmerged conditions.
 - Concrete must adhere to NSPI concrete spec SS –10.7 - Concrete Cast-in-Place with minimum 28-day compressive strength of 30 MPa.

Facilities Study Report

IR-618 - Goose Harbour Lake Wind



- Fencing
 - Chain link fencing must adhere to NSPI concrete spec SS-10 - Chain-link Fencing – Supply and Install.
- Structural Steel – Design, Fabrication and Welding
 - Steel design and fabrication shall follow SE-12 Steel Substation Structures – Fabricate & Supply.
 - Materials shall be new and of high commercial quality conforming to the requirements of CSA G40.20 and G40.21, unless noted otherwise.
- Land and access allocated for the interconnection substation shall have deeded ownership provided to NSPI.

2.3.1.2 125C-Grosvenor Site Specific

All cable trenches and conduits shall be installed with full separation of the ‘A’ and ‘B’ protection and control systems.

Concrete foundations and steel support structures will be installed for:

- 3 – 230kV tubular dead-ends
- 7 – 230kV high rigid bus supports
- 3 – 230kV low rigid bus supports
- 7 – 230kV disconnect supports
- 3 – 230V three phase potential transformer supports
- 2 – 132kV-120/240V single phase station service voltage transformer support
- 3 – 230kV three phase surge arrester supports

Concrete foundations (only) will be installed for:

- 3 – 230kV dead tank circuit breaker
- 1 – control building foundation
- 1 – self-supporting microwave radio tower foundation for 50m tower

2.3.2 Substation Grounding

A grounding grid system shall be installed for a design 3-phase fault level of 10,000MVA and meet NSPI’s substation grounding specification SD-2. A ground grid design to any fault level lower than 10,000MVA shall require NSPI approval.

The minimum acceptable size of conductor shall be 2/0 stranded copper. Equivalent copper-weld conductor should be used for above ground applications.

All structures, fencing, and equipment shall be grounded as per NSPI standards.

Facilities Study Report

IR-618 - Goose Harbour Lake Wind



2.3.3 Primary Equipment and Layout

A developmental substation layout for 125C is provided in Appendix D. All equipment shall conform with Nova Scotia Power standard equipment specifications.

2.3.3.1 Circuit Breakers 125C-701, 125C-702, and 125C-703

- 230kV, 2000A, 900kV BIL, 2 cycle, 31.5kA mom., SF6 dead-tank circuit breaker with independent pole operation.
- Complete with two sets (each side) of 2000/16/8/6-5A multi-ratio bushing current transformers.
- As per NSPI Standard Circuit Breaker Specification SE-14.

2.3.3.2 230kV Disconnects (125C-701A, 701B, 702A, 702B, 703A, 704B, and 723)

- 230kV, 2000A, 900kV BIL, 63kA mom., complete with 125Vdc motor operator.
- Line disconnects 125C-703A, 125C-702B and 125C-723 will also include an integral key interlocked ground switch.
- As per NSPI Standard Specification SE-8 (Outdoor Air Switches) and SE-10 (Air Switch Motor Operators).

2.3.3.3 230kV Voltage Transformers (P7003, P7024, and P7025)

- 2000/1200:1:1 with two 115/69V secondaries, 3000VA, 0.3 WXYZ, 900kV BIL
- As per NSPI Standard Specification SE-4

2.3.3.4 230kV Station Service Voltage Transformer (ST71 and ST72)

- 132kV – 120/240V single phase voltage transformer with KVA rating sized for full AC station service load

2.3.3.5 230kV Line Terminal Surge Arresters

- Station Type, Metal Oxide, 192kV rated, 152kV MCOV
- As per NSPI Standard Specification SE-20.

2.3.4 Protection and Control

At 125C, line protection on all three terminals will consist of redundant "A" and "B" protection schemes, with physical separation of panels and cabling between protection schemes, per Northeast Power Coordinating Council's (NPCC) Directory 4 criteria. The design shall be presented to NPCC Task Force on System Protection (TFSP) for approval and comment, prior to construction.

2.3.4.1 Line Protection

- The A scheme line protection relays shall be SEL-411L, with L-7024 and L-7025 relays using the 87L line current differential element for high-speed tripping and step distance elements for backup tripping. The line L-7003 relay will use distance elements with a permissive signal (POTT scheme) for high-speed tripping to match the remote end.
- The B scheme line protection relays shall be GE L90, with L-7024 and L-7025 relays using the 87L line current differential element for high-speed tripping and step distance elements for backup tripping. The line L-7003 relay will use distance elements with a permissive signal (POTT scheme) for high-speed tripping to match the remote end.

Facilities Study Report

IR-618 - Goose Harbour Lake Wind



- The line protection shall accommodate single pole tripping and reclosing.

2.3.4.2 Breaker Failure

- Redundant A and B breaker failure protection shall be provided.
- The A scheme breaker failure protection shall be provided by an SEL-451 bay control relay for each breaker, which shall also provide reclosing and synchronizing for the breaker.
- The B scheme breaker failure protection may be provided by the GE L90 line relays.
- Breaker Failure Initiate (BFI) must not be latched in the design. Breaker failure timer shall only run for (Trip active) AND (Breaker current above minimum pickup). The trip input to the BFI logic shall not be subject to a minimum trip duration.
- Transfer-tripping via high-speed tele-protection channels to the remote ends of line L-7003 and L-7024 shall be required for associated line breaker failures.
- Note: Breaker Failure protection is referred to as Breaker Backup (BBU) in NSPI documentation. A re-trip is referred to as "Early Trip."

2.3.4.3 Reclosing and Synchronizing

- Reclosing may be initiated in the SEL-451 relays by either the A or B protection schemes.
- The reclosing mode shall be Single Pole Auto Reclose (SPAR), Delayed 3 phase Auto Reclose (DAR) or both SPAR/DAR.
- The reclosing function shall have a single OFF/ON control for each breaker, regardless of the reclosing mode selected.
- Automatic synchronizing/sync check shall be provided by the SEL-451 bay control relays.
- Manual synchronizing shall also be provided.

2.3.4.4 DC Supply for Protection

Two redundant 125V DC battery banks along with battery chargers shall supply the DC protection and control systems. The batteries and chargers will be sized as part of the detailed design to fully accommodate all DC loads under simultaneous operation.

- Both A and B 125 Vdc batteries shall have the capacity to supply the entire substation. These will be designated 125C-D41 for the A battery and disconnect switch, and 125C-D42 for the B battery and disconnect switch.
- The two batteries shall be physically separated, preferably in separate battery rooms.
- DC distribution panels for the A and B systems shall not be located beside each other.
- Manual transfer capability shall be provided between the A and B dc systems to permit offline battery maintenance, however there shall be two normally open switches or breakers in this transfer path.

2.3.4.5 Station Control and Communications

- Station control, Remote Terminal Unit (RTU), and Sequence of Events Recording (SER) functions to be provided by a non-redundant SEL Axion system, including SEL-RTAC and SEL-3350 HMI computer, keyboard/trackpad tray and touch screen. These functions are collectively referred to as the Substation Automation system (SAS).

Facilities Study Report

IR-618 - Goose Harbour Lake Wind



- Communication to Supervisory Control and Data Acquisition (SCADA) master will use DNP3 protocol over a serial channel.
- Network connections between different panels shall be via fiber optic cable. Network connections within a panel may be copper cabling (Cat 5e or Cat 6).
- Sequence of Events Recording (SER) and Fault Recording (FR) shall meet the requirements of NERC Reliability standard PRC-002 and NPCC Directory 11.
- A non-redundant SEL-2488 satellite clock shall be provided.
- A time signal shall be distributed to each measuring relay using either PTP (IEEE 1588-2008 or later) or IRIG-B timecode over 50 ohm coaxial cable, taking care to maintain galvanic isolation between A and B side equipment.
- Each protective relay shall assert an alarm to the SAS in the event of a loss of satellite clock signal.
- Ethernet switches shall be capable of supporting PTP with the C37.238-2017 power system profile.
- Local substation operation, including tagging functions, shall normally be from the HMI computer/Substation Automation System (SAS).
- In the event of a failure of the SAS, local manual operation of the breakers shall be available from inside the control building.
- Redundant communications paths shall be provided for 125C tele-protection channels.
- Redundant communication paths shall be provided for 126C tele-protection channels.

2.3.4.6 Station Alarms

The following substation alarms will be provided to the local Sequence of Events Recorder (SER) and SCADA (unless otherwise noted):

1. Urgent (SCADA) time delayed & initiated by following SER points:
 - Station Service Failed
 - A Battery(s) Volts Low
 - B Battery(s) Volts Low
 - A Battery Charger(s) Failed
 - B Battery Charger(s) Failed
 - A Protection and Control Relay/DC Failed
 - B Protection and Control Relay/DC Failed
 - A Protection AC Potential Failed
 - B Protection AC Potential Failed
 - Breaker Trip Circuit #1 Failed
 - Breaker Trip Circuit #2 Failed
 - Line L-7003 A Tele-protection Channels Failed
 - Line L-7003 B Tele-protection Channels Failed
 - Line L-7024 A Tele-protection Channels Failed
 - Line L-7024 B Tele-protection Channels Failed
 - Line L-7025 A Tele-protection Channels Failed
 - Line L-7025 B Tele-protection Channels Failed
 - Fire Alarm Operated
 - Building High Temperature
 - Building Low Temperature
2. Non-Urgent (Scada) time delayed & initiated by following SER points:
 - Alternate Station Service Failed
 - Station Service Auto Transfer Operated

Facilities Study Report

IR-618 - Goose Harbour Lake Wind



- A DC Supply(s) Grounded
- B DC Supply(s) Grounded
- Breaker 701 Monitor Trouble
- Breaker 702 Monitor Trouble
- Breaker 703 Monitor Trouble
- Line L-7003 #1 Permissive From 67N Received (SER only)
- Line L-7003 #2 Permissive From 67N Received (SER only)
- Line L-7003 #1 Permissive To 67N Sent (SER only)
- Line L-7003 #2 Permissive To 67N Sent (SER only)
- Relay Time Sync Failed
- 3. A Transfer Trip Received (Scada) initiated by following SER points:
 - Line L-7003 #1 Transfer Trip From 67N Received
 - Line L-7024 #1 Transfer Trip From 3C Received
 - Line L-7025 #1 Transfer Trip From 126C Received
- 4. B Transfer Trip Received (Scada) initiated by following SER points:
 - Line L-7003 #2 Transfer Trip From 67N Received
 - Line L-7024 #2 Transfer Trip From 3C Received
 - Line L-7025 #2 Transfer Trip From 126C Received
- 5. Line L-7003 A Protection Operated (SER only)
- 6. Line L-7003 B Protection Operated (SER only)
- 7. Line L-7024 A Protection Operated (SER only)
- 8. Line L-7024 B Protection Operated (SER only)
- 9. Line L-7025 A Protection Operated (SER only)
- 10. Line L-7025 B Protection Operated (SER only)
- 11. Sync Freq Limit Exceeded (Scada) initiated by following SER point:
 - Synchronizing Frequency Limit Exceeded
- 12. Sync Volt Limit Exceeded (Scada) initiated by following SER point:
 - Synchronizing Voltage Limit Exceeded
- 13. Sync Phase Angle Limit Exceeded (Scada) initiated by following SER point:
 - Synchronizing Phase Angle Limit Exceeded
- 14. Local Control (Scada) initiated by following SER point:
 - Station Control Local
- 15. Breaker 701 Closed
- 16. Breaker 702 Closed
- 17. Breaker 703 Closed
- 18. Breaker 701 Urgent (Scada) initiated by following SER points:
 - Breaker 701 SF6 Density Low
 - Breaker 701 Motor Overload*
- 19. Breaker 702 Urgent (Scada) initiated by following SER points:
 - Breaker 702 SF6 Density Low
 - Breaker 702 Motor Overload*
- 20. Breaker 703 Urgent (Scada) initiated by following SER points:
 - Breaker 703 SF6 Density Low
 - Breaker 703 Motor Overload*
- 21. Breaker 701 Control Lockout (Scada) initiated by following SER point:
 - Breaker 701 SF6 Control Blocked
- 22. Breaker 702 Control Lockout (Scada) initiated by following SER point:
 - Breaker 702 SF6 Control Blocked
- 23. Breaker 703 Control Lockout (Scada) initiated by following SER point:
 - Breaker 703 SF6 Control Blocked
- 24. Breaker 701 Auto-reclose Off (Scada) initiated by following SER point:

Facilities Study Report

IR-618 - Goose Harbour Lake Wind



- Breaker 701 Auto-reclose Off
- 25. Breaker 702 Auto-reclose Off (Scada) initiated by following SER point:
 - Breaker 702 Auto-reclose Off
- 26. Breaker 703 Auto-reclose Off (Scada) initiated by following SER point:
 - Breaker 703 Auto-reclose Off
- 27. Breaker Backup Lockout (Scada) initiated by following SER points:
 - Breaker 701 BBU Lockout Operated
 - Breaker 702 BBU Lockout Operated
 - Breaker 703 BBU Lockout Operated
- 28. Breaker 701 BBU Initiated & Early Trip Operated (SER) only
- 29. Breaker 702 BBU Initiated & Early Trip Operated (SER) only
- 30. Breaker 703 BBU Initiated & Early Trip Operated (SER) only
- 31. Substation Entry

*Note: These alarms may differ depending on the manufacturer of the breakers purchased.

2.3.4.7 General

- Specific part numbers for IEDs and equipment remain to be determined.
- A single line protection panel may include two relays for two lines, or a line relay and a bay control relay if this makes economic use of panel space.
- If IEC 61850 is used for protection functions, the network design shall meet NPCC Directory 4 criteria.
- If serial connections are used for communication between relays and/or the SAS, serial fiber shall be used between A and B systems. I.e. If the SAS is supplied from the A battery, serial connection to B IEDs shall be over fiber.
- If the physical design of the 125C substation permits the addition of a fourth breaker to accommodate a fourth line terminal, then the protection panel layout shall also accommodate additional relaying.
- Remote engineering access shall be provided via an NSPI-supplied firewall to be installed in either an NSPI telecom panel or the SAS panel.

2.3.5 Control Building

A control building to house the redundant and physically separated protection and control panels, physically separated dual path tele-communications equipment, redundant and physically separated batteries and chargers, and physically separated primary and back-up station service supplies is required. The final size of the control building shall be determined during detailed design. A marshalling box shall be provided in the control building to interface all control cabling from external equipment.

The full extent of Remedial Action Scheme (RAS) modifications will not be determined until detailed design. Additional space shall be available in the control building at 125C-Grosvenor to accommodate a single non-redundant RAS panel in case one is determined to be required.

Facilities Study Report

IR-618 - Goose Harbour Lake Wind



2.4 New 230kV Transmission L-7025

2.4.1 Basis of Design

The 230kV transmission line (L-7025) from the interconnection substation 125C-Grosvenor to 126C-Goose Harbour Lake substation shall be 230kV wood pole gulf-port construction as per NSPI standard design. The total length of line is approximately 2.1 kms. The primary conductor shall be 1113 ACSR Beaumont with a thermal rating of 70 deg C. Two overhead shield wires will be installed, one with embedded fibres for telecommunications. Alternative design with steel pole construction would also be acceptable, subject to NSPI's review and approval, providing all basis of design criteria is met.

A Basis of Design document for transmission line L-7025 is provided in Appendix J.

The Interconnection Customer is required to provide NSPI with easement and access rights for the transmission line right of way and is responsible for obtaining all necessary construction permits.

2.4.2 Environmental

All land restrictions, environmental conditions, and construction activities shall comply with NSPI procedures, all existing laws and regulations and any environmental assessment requirements.

2.5 Remedial Action Scheme (RAS) Modifications

NSPI utilize special protection schemes or Remedial Action Schemes (RAS) to manage system power flow conditions.

- Modifications will be required to the Group 3 and possibly Group 4 RAS logic at the 3C-Port Hastings substation (to be determined during detailed design).
- At a minimum, breaker statuses and protection trips from 125C-Grosvenor will be sent via high-speed tele-protection channels to the RAS panel at 3C-Port Hastings substation, to be incorporated into the RAS panel logic there.
- The full extent of Remedial Action Scheme (RAS) modifications will not be determined until detailed design. Additional space shall be available in the control building at 125C-Grosvenor to accommodate a single non-redundant RAS panel in case one is determined to be required.
- All additions and/or modifications to RAS are subject to Northeast Power Coordinating Council (NPCC) approval.

Estimated costs associated with the RAS modifications are included in the Non-Stand-Alone Network Upgrade cost estimate.

2.6 Terminal Station: 126C-Goose Harbour Lake Wind

2.6.1 Terminal Station One-Line

A Basic One Line diagram of the Interconnection Customer's substation 126C-Goose Harbour Lake Wind substation is provided in Appendix I.

Facilities Study Report

IR-618 - Goose Harbour Lake Wind



2.6.2 Protection and Control at 126C–Goose Harbour Lake

At 126C, 230 kV protection will consist of redundant "A" and "B" protection schemes, with physical separation of panels and cabling between protection schemes, per Northeast Power Coordinating Council's (NPCC) Directory 4 criteria. The design shall be presented to the NPCC Task Force on System Protection (TFSP) for approval and comment, prior to construction.

2.6.3 Protection and Control Assets at 126C–Goose Harbour Lake

The Interconnection Customer shall provide space and unrestricted access in the Interconnection Customer's substation control building for NSPI's protection, communications, and control equipment.

NSPI will require space and access for an RTU, A and B communication panels plus two line current differential protection panels. The space allocated for the redundant "A" and "B" protection schemes shall adhere to the physical separation of panels and cabling requirements, as per Northeast Power Coordinating Council's (NPCC) Directory 4 criteria.

Estimated costs associated with these protection, control, and communication assets are included in the Non-Stand-Alone Network Upgrade cost estimate.

2.6.3.1 230 kV Line Protection

- The A scheme line protection relay shall be SEL-411L, using the 87L line current differential element for high-speed tripping and step distance elements for backup tripping.
- The B scheme line protection relay shall be GEL90, using the 87L line current differential element for high-speed tripping and step distance elements for backup tripping.
- The line protection may accommodate single pole tripping and reclosing.

2.6.3.2 Breaker Failure

- Redundant A and B breaker failure protection shall be provided for the 230 kV circuit breaker(s).
- Breaker Failure Initiate (BFI) must not be latched in the design. Breaker failure timer shall only run for (Trip active) AND (Breaker current above minimum pickup). The trip input to the BFI logic shall not be subject to a minimum trip duration.
- Transfer tripping via NSPI-supplied redundant A and B high speed tele-protection channels to the remote end of line L-7025 shall be required for breaker failure.

2.6.3.3 Reclosing and Synchronizing

- If included in the design, automatic reclosing may be initiated by either the A or B line protection schemes.
- The reclosing mode may be Single Pole Auto Reclose (SPAR), Delayed 3 phase Auto Reclose (DAR) or both SPAR/DAR.
- The reclosing function shall have a single OFF/ON control for each breaker, regardless of the reclosing mode selected.

Facilities Study Report



IR-618 - Goose Harbour Lake Wind

- Automatic synchronizing/sync check shall be provided.
- Automatic reclosing, if enabled, shall only occur with a live line/dead bus condition.

2.6.3.4 DC Supply for Protection

Two redundant 125V DC battery banks along with battery chargers shall supply the DC protection and control systems. The batteries and chargers will be sized as part of the detailed design to fully accommodate all DC loads under simultaneous operation.

- Both A and B 125 Vdc batteries shall have the capacity to supply the entire substation.
- The two batteries shall be physically separated, preferably in separate battery rooms.
- DC distribution panels for the A and B systems shall not be located beside each other.
 - NSPI panels located at 126C-Goose Harbour Lake Wind shall be supplied by dedicated dc circuits from the dc distribution panels.
- Manual transfer capability shall be provided between the A and B dc systems to permit offline battery maintenance, however there shall be two normally open switches or breakers in this transfer path.

2.6.3.5 Station Control and Communications

- Communication to Supervisory Control and Data Acquisition (SCADA) master will use DNP3 protocol over a serial channel.
- Communication between the substation RTU and the wind farm control system will use DNP3 protocol over a serial channel.
- Communication between the substation RTU and the Substation Automation System (SAS) will use DNP3 protocol over a serial channel.
- Sequence of Events Recording (SER) and Fault Recording (FR) functions shall be included in the station design.
- SER and FR functions shall meet the requirements of NERC Reliability standard PRC-002 and NPCC Directory 11.
- A non-redundant satellite clock shall be provided.
- A time signal shall be distributed to each measuring relay using either Precision Time Protocol (PTP) (IEEE 1588-2008 or later) or IRIG-B time code over 50 ohm coaxial cable, taking care to maintain galvanic isolation between A and B side equipment.
- Each protective relay shall assert an alarm to the SER in the event of a loss of satellite clock signal.
- If PTP is used, then Ethernet switches shall be capable of supporting PTP with the C37.238-2017 power system profile.
- In the event of a failure of the Substation Automation System (SAS), local manual operation of the breakers shall be available from inside the control building.
- Redundant communication paths shall be provided for 126C A and B tele-protection channels.

2.6.3.6 Station Alarms

The following substation alarms will be provided to the local Sequence of Events Recorder (SER) and SCADA (unless otherwise noted):

Facilities Study Report

IR-618 - Goose Harbour Lake Wind



1. Urgent (SCADA) time delayed & initiated by following SER points:
 - Station Service Failed
 - A Battery(s) Volts Low
 - B Battery(s) Volts Low
 - A Battery Charger(s) Failed
 - B Battery Charger(s) Failed
 - A Protection and Control Relay/DC Failed
 - B Protection and Control Relay/DC Failed
 - A Protection AC Potential Failed
 - B Protection AC Potential Failed
 - Breaker Trip Circuit #1 Failed
 - Breaker Trip Circuit #2 Failed
 - Line L-7025 A Tele-protection Channels Failed
 - Line L-7025 B Tele-protection Channels Failed
 - Fire Alarm Operated
 - Building High Temperature
 - Building Low Temperature
2. Non-Urgent (Scada) time delayed & initiated by following SER points:
 - Alternate Station Service Failed
 - Station Service Auto Transfer Operated
 - A DC Supply(s) Grounded
 - B DC Supply(s) Grounded
 - Relay Time Sync Failed
3. A Transfer Trip Received (Scada) initiated by following SER points:
 - Line L-7025 #1 Transfer Trip From 125C Received
4. B Transfer Trip Received (Scada) initiated by following SER points:
 - Line L-7025 #2 Transfer Trip From 125C Received
5. Line L-7025 A Protection Operated (SER only)
6. Line L-7025 B Protection Operated (SER only)
7. Local Control (Scada) initiated by following SER point:
 - Station Control Local
8. Breaker 7xx Closed
9. Breaker 7xx Urgent (Scada) initiated by following SER points:
 - Breaker 7xx SF6 Density Low
 - Breaker 7xx Motor Overload*
10. Breaker 7xx Control Lockout (Scada) initiated by following SER point:
 - Breaker 7xx SF6 Control Blocked
11. Breaker 7xx Auto-reclose Off (Scada) initiated by following SER point:
 - Breaker 7xx Auto-reclose Off
12. Breaker Backup Lockout (Scada) initiated by following SER points:
 - Breaker 7xx BBU Lockout Operated
13. Breaker 7xx BBU Initiated & Early Trip Operated (SER) only
14. Substation Entry

*Note: These alarms may differ depending on the manufacturer of the breakers purchased.

Facilities Study Report



IR-618 - Goose Harbour Lake Wind

2.6.4 Station Service

The Interconnection Customer shall provide dedicated 120V AC and 125V DC circuits from Interconnection Customer's substation building AC distribution and DC distribution panels to supply the NSPI owned protection and control panels.

2.6.5 Revenue Metering

Revenue metering shall be installed at 126C as detailed in section 2.8. The Interconnection Customer will supply the 230kV revenue class current and voltage transformers, supporting structures, test switch, and meter base. The supply and installation of revenue metering equipment is considered part of the Interconnection Customers' Terminal Station and are not included in the cost estimates in this Facilities Study.

2.6.6 Canadian Electrical Code

The customer owned substation 126C-Goose Harbour Lake Wind shall be designed and constructed to comply with Canadian Electrical Code requirements.

2.7 Remote Terminal Protection Modifications

The A and B line protection relays for L-7024 at 3C-Port Hastings will be replaced to match the relays to be installed at 125C-Grosvenor. Estimated costs associated with these protection modifications are included in the Non-Stand-Alone Network Upgrade cost estimate.

2.8 Revenue Metering

A 230kV revenue metering system, owned by NSPI, shall be installed at the Interconnection Customer's substation (126C).

230kV revenue class current and voltage transformers will be supplied and installed by the Customer complete with supporting structures, test switch, and meter base as per Nova Scotia Power metering standard STD 5.12 (attached as Appendix H: Revenue Metering).

The revenue metering class potential and current transformers shall not be embedded in any other piece of equipment and shall be certified by Measurement Canada for three element metering. Nova Scotia Power shall provide the technical specifications for the required current and voltage transformers to the Interconnection Customer.

Nova Scotia Power will install the revenue meter at the Interconnection Customer's substation once the commissioning is complete and the system is ready for energization.

Facilities Study Report

IR-618 - Goose Harbour Lake Wind



2.9 Tele-Communications

The 125C-Grosvenor substation and the 126C-Goose Harbour Lake Wind substation are both classified as bulk power and require fully redundant communication paths.

The redundant telecommunications paths for both the 125C-Grosvenor substation and the 126C-Goose Harbour Lake substation will be installed as per the following:

Dual Communications Paths to 125C-Grosvenor

Path A: Microwave radio: Grosvenor to NSPI Horton Lake radio

Path B: Microwave radio: Grosvenor to NSPI Creignish Radio

Dual Communications Paths to 125C-Grosvenor to 126C-Goose Harbour Lake

Path A: Optical Fibre (L-7025): Grosvenor to Goose Harbour Lake

Path B: Microwave radio: Grosvenor to Goose Harbour Lake

A 50m self-supporting tower will be required at 125C-Grosvenor Substation. This tower will accommodate the microwave radio antennae for the Path A system from Grosvenor to Horton Lake, the Path B system from Grosvenor to Creignish, and the Path B system from Grosvenor to Goose Harbour Lake. A 22m self-supporting tower will be required at 126C-Goose Harbour Lake Wind substation. Both radio towers will be enclosed in their own fenced area near the 125C and 126C substations.

The new transmission line L-7025 from 125C to 126C will be constructed with an Optical Ground Wire (OPGW) in one of the two shield wires. This will provide the communications Path A from 125C to 126C.

The costs to install the OPGW in the new L-7025 transmission line are included in the transmission line estimate. All other costs associated with these telecommunication assets are included in the Non-Stand-Alone Upgrade cost estimate.

2.10 Stand Alone Upgrades Categorization

In the event NSPI cannot meet the Interconnection Customer's schedule expectation or as agreed in the terms of the Generation Interconnection Agreement (GIA), the Interconnection Customer may take responsibility for design, procurement, and construction activities associated with NSPI owned assets.

These design, procurement, and construction activities are limited to upgrades deemed to be 'Transmission Providers Interconnection Facilities (TPIF)' or 'Stand Alone Network Upgrades', defined as:

Transmission Provider's Interconnection Facilities shall mean all facilities and equipment owned, controlled, or operated by the Transmission Provider from the Point of Change of Ownership to the Point of Interconnection as identified in Appendix A to the Standard Generator Interconnection and Operating Agreement, including any modifications, additions or upgrades to such facilities and equipment.

Stand Alone Network Upgrades shall be defined as Network Upgrades that the Interconnection Customer may construct without affecting day-to-day operations of the

Facilities Study Report

IR-618 - Goose Harbour Lake Wind



Transmission System during their construction.

The Goose Harbour Lake Wind transmission interconnection includes both Network Upgrades and Transmission Provider Interconnection Facilities. Should the Interconnection Customer decide to exercise their 'Option to Build', NSPI have defined the upgrades in terms of what would be considered stand-alone facilities and may be constructed without affecting day-to-day operations of the Transmission System.

2.10.1 'Stand-Alone' Network Upgrades and 'Stand-Alone' TPIF

The following scope of work meets the defined criteria for 'Stand Alone' Network Upgrades or Stand-Alone TPIF:

- Stand-Alone Network Upgrade:
 - The interconnection substation (125C-Grosvenor) including land acquisition, site preparation, access road, foundations, site grounding, primary equipment, control building, protection and control panels, and all associated devices except for the telecommunications equipment and the microwave radio tower.
- Stand-Alone TPIF
 - The transmission line L-7025 from 125C-Grosvenor to 126C-Goose Harbour Lake Wind substation including easement acquisition, access routes, all structures, conductors, shield wires, insulators, and foundations, the optical fibre shield wire, line terminations at both substations, and all potential railway, highway, and water crossings.

The cost estimate for the 'Stand-Alone' Network Upgrades and Transmission Provider Interconnection Facilities is the total of the estimate provided for L-7025 transmission line and the estimate provided for 125C-Grosvenor substation (see Appendix F).

2.10.2 Non-Stand-Alone Network Upgrades and Non-Stand-Alone TPIF

Non-stand-alone network upgrades include all other elements of the scope of work not identified as stand-alone upgrades:

- Non-Stand-Alone Network Upgrades
 - The 230kV transmission line tap to existing L-7003 at 125C-Grosvenor Substation
 - The remote protection modifications at 3C-Port Hastings
 - The modifications to existing Remedial Actions Schemes (RAS).
 - Telecommunications equipment supply and installation at 125C-Grosvenor Substation.
- Non-Stand-Alone TPIF
 - The revenue meter, NSPI's L-7025 protection and control equipment, remote terminal unit (RTU), and telecommunications equipment required at 126C-Goose Harbour Lake Wind substation.

Interfaces and commissioning activities requiring joint collaboration shall be identified during the detailed design phase and prior to construction.

The cost estimate for the 'Non-Stand-Alone' Network Upgrades and TPIF have been broken out as separate cost estimates (see Appendix F).

Facilities Study Report

IR-618 - Goose Harbour Lake Wind



3.0 PERMITS, APPROVALS, AND STANDARDS

The Interconnection Customer is responsible to obtain all permits and approvals required to construct the interconnection substation at 125C-Grosvenor and the new transmission line L-7025 from 125C-Grosvenor substation to 126C-Goose Harbour Lake Wind substation.

The Nova Scotia Electrical Inspection Act requires that electrical work be performed under permit. Contractors must take out permits for work at voltage levels below and above 750V – including work on customer owned substations. Plans must be submitted for review and all equipment must be approved by a recognized certification authority (CSA, ULC, etc.).

The customer facilities are subject to the minimum requirements of the latest edition of the Canadian Electrical Code, CSA C22.1, and other applicable CSA standards, for the purpose of electrical inspection. The cost associated with acquiring wiring permits and the associated electrical inspections are the responsibility of the customer. No equipment will be connected or energized without authorization of the electrical inspector.

Where applicable, all NPCC bulk power standards must be met.

The interconnection substation installation will be subject to the review and approval by Nova Scotia Power to ensure coordination of the Nova Scotia Power and Interconnection Customer's scopes of work.

Facilities Study Report

IR-618 - Goose Harbour Lake Wind



4.0 DESIGN AND CONSTRUCTION

NSPI will be responsible for the design and engineering drawing production for all aspects of the scope of work from the Point of Interconnection to the Point of Change of Ownership unless otherwise specified and agreed in the Generation Interconnection Agreement (GIA). NSPI will also be responsible for the design of any other associated network upgrades or modifications identified in the Study Impact Study.

NSPI will be responsible for the procurement and construction of all aspects of the scope of work from the Point of Interconnection to the Point of Change of Ownership and any associated network upgrades unless otherwise specified in the Generation Interconnection Agreement (GIA).

Interconnection Customer's responsibility for design, procurement, and construction scope of work shall be limited to Stand-Alone Upgrades as identified in Section 2.10 of this report.

The construction work associated with this interconnection will require planned outages to existing system components. Planned system outages must be coordinated with NSPI System Operations and will be restricted to opportunities when system reliability risks are acceptable.

Facilities Study Report

IR-618 - Goose Harbour Lake Wind



5.0 SCHEDULE MILESTONES

The Interconnection Customer's targeted commercial operation date is December 2025.

A preliminary project schedule outlining major components is provided in Appendix G.

A series of milestone target dates (listed below) were assumed based on optimistic timelines for the purpose of drafting a schedule for this Facilities Study. The in-service dates provided in this schedule are based on achieving these milestones. Missing any of these milestones increases the risk to meeting the proposed commercial operation date.

Facilities Study Complete	End of Q3, 2023
Generation Interconnection Agreement Executed	Q4, 2023
Detailed Design Start – L-7003 Line Tap	Q2, 2024
Detailed Design Start – Substation 125C (Grosvenor)	Q4, 2023
Detailed Design Start – L-7025	Q1, 2024
Procurement of Long Lead Items Start	Q4, 2023
L-7025 Right of Way Tree Clearing Complete	Q1, 2024
125C Substation Construction Start	Q3, 2024
L-7025 Construction Start	Q3, 2024
L-7003 Line Tap Complete (Actual timing to coordinate with earliest line outage available opportunity)	Q2, 2025
Remote Terminal Protection and RAS Modifications Complete	Q2, 2025
First Power Available	Q3, 2025
Commercial Operation	December, 2025

Facilities Study Report

IR-618 - Goose Harbour Lake Wind



6.0 COST ESTIMATE

The cost estimates have been produced using 2023 budgetary rates. They do not include a allowance for funds during construction (AFUDC) or any escalations due to timing of project execution.

The cost estimates are based on the conceptual design outlined in this report and should be considered as a class 3 accuracy level (-20% / +30%).

The cost estimates include project overheads based on NSPI's typical internal capital administration overhead allocation process.

A contingency of 10% has been included in the estimates to account for any unforeseen scope changes or supply chain issues.

For this Facilities Study the cost estimates have been broken out into four blocks:

1. Network Upgrade: Stand-Alone Interconnection Substation 125C-Grosvenor
2. Network Upgrades – Non-Stand-Alone
3. TPIF: Stand-Alone: Transmission Line L-7025
4. TPIF – Non-Stand-Alone

Cost Estimate Summary:

Upgrade Component	Cost Estimate
Network Upgrades – Stand Alone	
Interconnection Substation – 125C Grosvenor	\$8,763,199
Network Upgrades – Non-Stand-Alone	
230kV line tap to existing L-7003 at 125C-Grosvenor Substation; remote protection modifications at 3C-Port Hastings; modifications to existing Remedial Actions Schemes (RAS); telecommunications equipment supply and installation at 125C-Grosvenor Substation.	\$2,252,485
Network Upgrade Sub-Total	\$11,015,684
TPIF - Stand-Alone	
Transmission Line L-7025 (2.1kms)	\$2,780,287
TPIF - Non-Stand-Alone	
The revenue meter, NSPI's L-7025 protection and control equipment, remote terminal unit (RTU), and telecommunications equipment required at 126C-Goose Harbour Lake Wind substation.	\$1,269,942
TPIF Sub-Total	\$4,050,229
Total	\$15,065,913
Sub-Total (Stand-Alone)	\$11,543,486
Sub-Total (Non-Stand-Alone)	\$3,522,427

A more detailed breakdown of each cost estimate is provided in Appendix F.

Facilities Study Report

IR-618 - Goose Harbour Lake Wind



7.0 COMMISSIONING / OPERATIONS

NS Power reserves the right to inspect all Interconnection Facilities identified in this study prior to connection to the NS Power Transmission System to ensure the facility design and construction will not adversely affect the reliability of the Transmission System. All Interconnection Facilities are subject to NS Power's review and acceptance of all testing and commissioning requirements and results. Construction, switching, testing, and commissioning schedules that affect the reliable and stable operation of the Transmission System shall be coordinated with the Nova Scotia Power System Operator.

L-7003 shares a transmission line corridor with L-7004 and L-6515. Outages to any of these lines impose limitations on Cape Breton export energy flows. These constraints will require NSPI System Operator actions to minimize risks and maintain system stability. All system outages required to complete the interconnection work shall require advanced planning and coordination with the NS System Operator.

All interconnection facilities must meet NSPI's Transmission System Interconnection Requirements (TSIR) as published on the NSPI OASIS site as well as NPCC bulk power system facility requirements.

Facilities Study Report

IR-618 - Goose Harbour Lake Wind



Appendices

APPENDIX A – INTERCONNECTION FACILITIES STUDY AGREEMENT

APPENDIX B – INTERCONNECTION OVERVIEW

APPENDIX C – INTERCONNECTION SUBSTATION DEVELOPMENTAL ONE LINE

APPENDIX D – INTERCONNECTION SUBSTATION DEVELOPMENTAL PLAN VIEW

APPENDIX E – INTERCONNECTION SUBSTATION DEVELOPMENTAL OVERALL PLAN

APPENDIX F – COST ESTIMATE DETAILS

APPENDIX G – PRELIMINARY PROJECT SCHEDULE

APPENDIX H – REVENUE METERING

APPENDIX I – 126C-GOOSE HARBOUR LAKE TERMINAL STATION ONE LINE

APPENDIX J – TRANSMISSION LINE (L-7025) BASIS OF DESIGN

APPENDIX K – PROPOSED TRANSMISSION LINE ROUTING FOR L-7025

APPENDIX L – MINUTES OF FACILITIES STUDY REVIEW MEETING

Facilities Study Report

IR-618 - Goose Harbour Lake Wind



Appendix A – Interconnection Facilities Study Agreement

(Attachment 1)

Facilities Study Report

IR-618 - Goose Harbour Lake Wind



Appendix B – Interconnection Overview

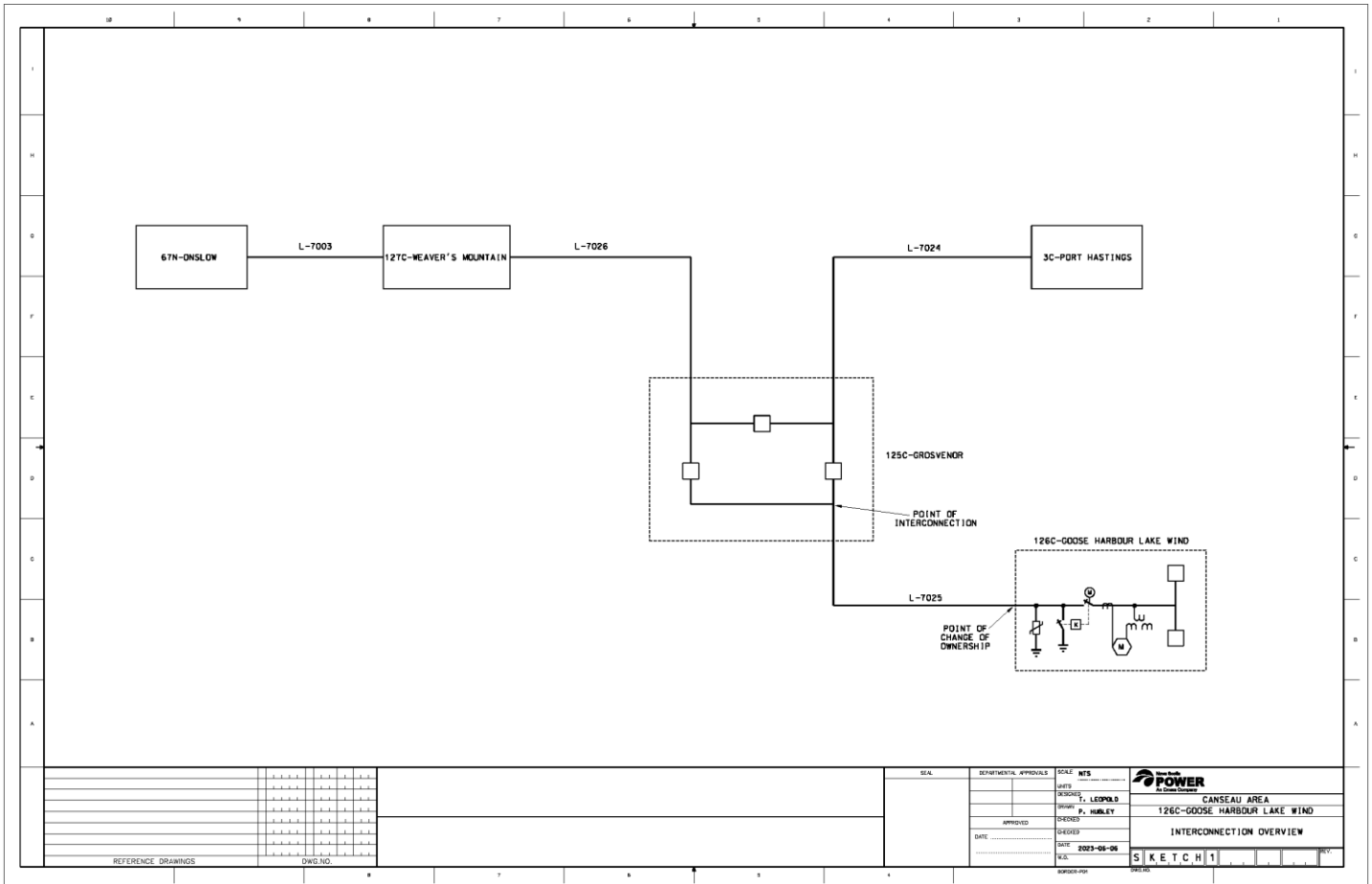

Facilities Study Report

IR-618 - Goose Harbour Lake Wind



Appendix D – Interconnection Substation Developmental Plan View

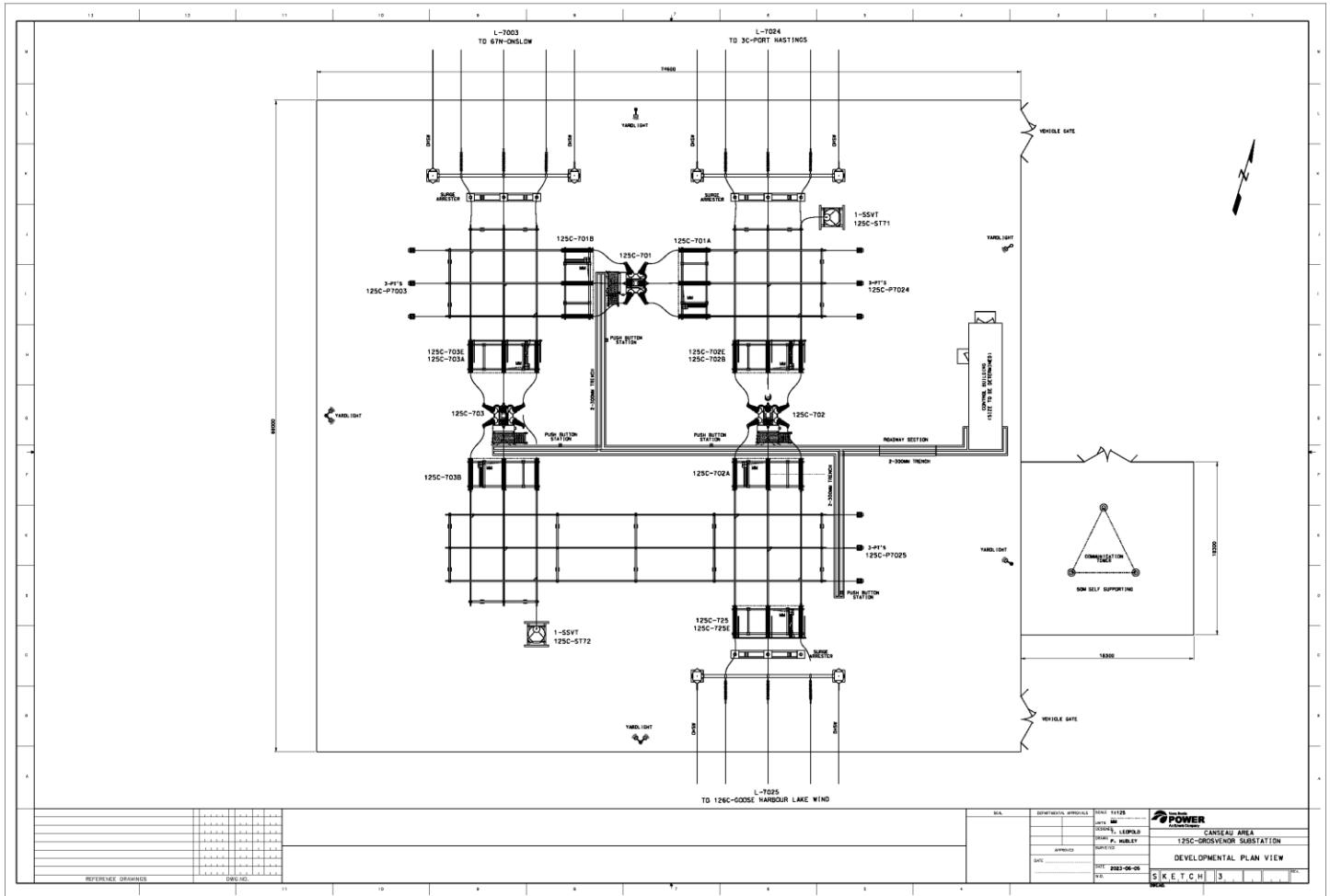

Facilities Study Report

IR-618 - Goose Harbour Lake Wind



APPENDIX E – INTERCONNECTION SUBSTATION DEVELOPMENTAL OVERALL PLAN

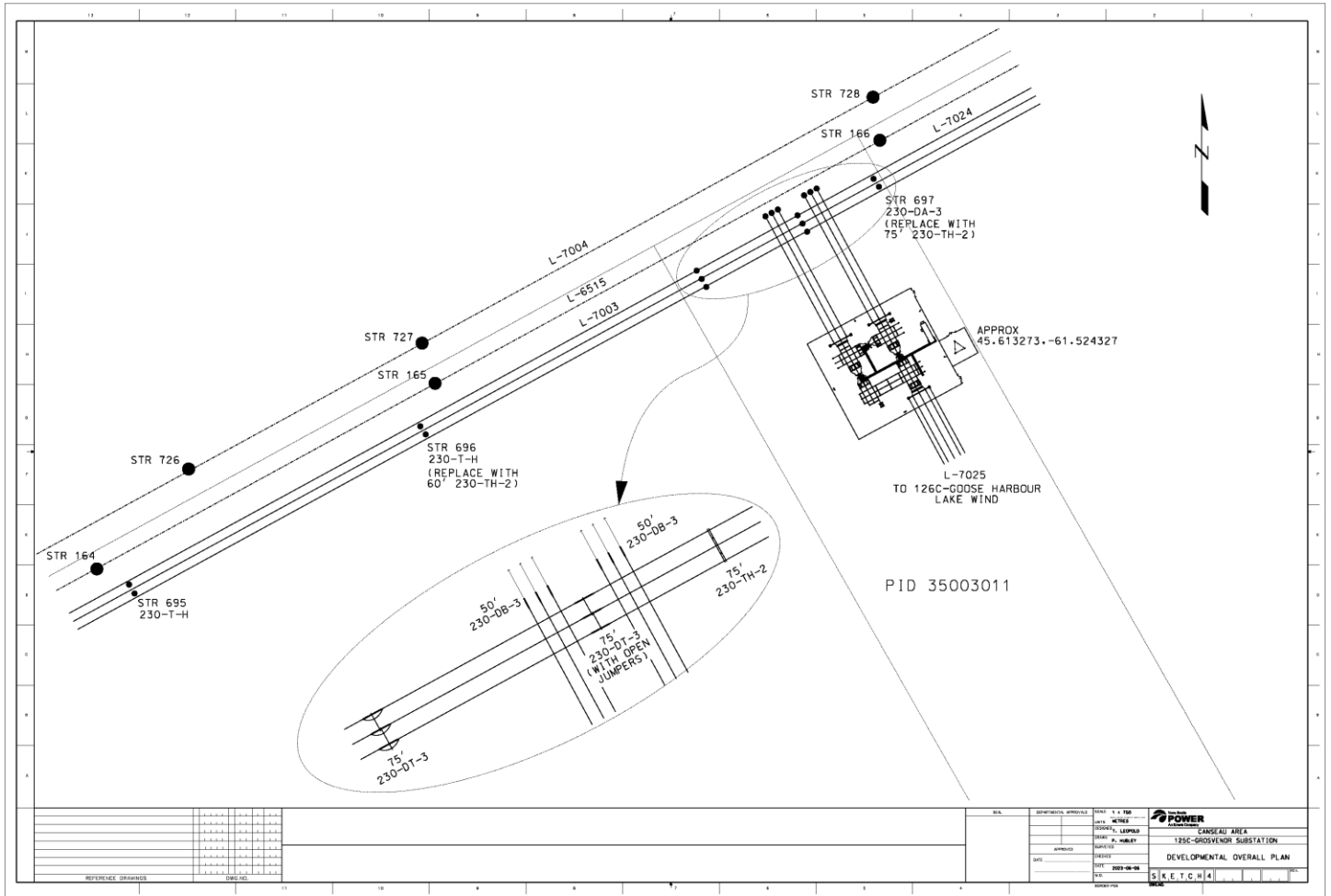

Facilities Study Report

IR-618 - Goose Harbour Lake Wind



Appendix F – Cost Estimate Details

‘Stand-Alone’ Upgrades:

Stand-Alone Network Upgrade: New Substation – 125C Grosvenor

Goose Harbour Lake FAC Interconnection Substation - 125C										
		Project Number:								
		Cost Centre:		900						
		Labour		Material	Expenses			Contracts	Consulting	Totals
Activity	Accounts -->	535050	535200	531400	530950	533410	533400	531550	532500	
003	Buildings, Structures and Grounds	0	0	493,500	0	0	0	2,557,300		3,050,800
022	Electrical Control Equipment	0	0	1,517,200	0	0	0	120,000		1,637,200
043	Substation Devices	25,783	0	1,440,000	0	0	0	217,000		1,682,783
061	Telephone Equipment (/ Comm Equip.)	0	0	0	0	0	0	0		0
085	Design (i.e. Engineering)	70,119		0	1,110		2,500	0	358,000	431,729
086	Commissioning	174,088	0	0	0	1,500	0	0		175,588
087	Field Supervision and Operations	16,390	0	0	29,850		0	160,000		206,240
	Sub-Total	286,380	0	3,450,700	30,960	1,500	2,500	3,054,300	358,000	7,184,340
085	Contingency	28,638	0	345,070	3,096	150	250	305,430	35,800	718,434
	Sub-Total	315,018	0	3,795,770	34,056	1,650	2,750	3,359,730	393,800	7,902,774
005	Vehicle Allocation (Labour & Eng'g)				114,812					114,812
005	Construction Overhead (Labour)							207,839		207,839
005	Construction Overhead (Contracts)							537,774		537,774
	Sub-Total				114,812			745,613		860,425
	Totals	315,018	0	3,795,770	148,868	1,650	2,750	4,105,343	393,800	8,763,199

Stand-Alone TPIF: New Line L-7025

Goose Harbour Lake Facilities Study - Transmission Line L-7025										
		Project Number:								
		Cost Centre:		900						
		Labour		Material	Expenses			Contracts	Consulting	Totals
Activity	Accounts -->	535050	535200	531400	530950	533410	533400	531550	532500	
035	Wood Poles	5,018	0	735,000	0	0	0	1,155,000		1,895,018
085	Design (i.e. Engineering)	12,787		0	740		500	0	250,000	264,027
087	Field Supervision and Operations	0	0	0	1,850		7,500	50,000		59,350
088	Survey and Mapping	2,578		0	0		0	80,000	0	82,578
	Sub-Total	20,383	0	735,000	2,590	0	8,000	1,285,000	250,000	2,300,973
085	Contingency	2,038	0	73,500	259	0	800	128,500	25,000	230,097
	Sub-Total	22,422	0	808,500	2,849	0	8,800	1,413,500	275,000	2,531,071
005	Vehicle Allocation (Labour & Eng'g)				8,172					8,172
005	Construction Overhead (Labour)							14,793		14,793
005	Construction Overhead (Contracts)							226,251		226,251
	Sub-Total				8,172			241,045		249,216
	Total	22,422	0	808,500	11,021	0	8,800	1,654,545	275,000	2,780,287

Facilities Study Report

IR-618 - Goose Harbour Lake Wind



'Non-Stand-Alone' Upgrades:

Non-Stand-Alone Network Upgrades

- The 230kV transmission line tap to existing L-7003 at 125C-Grosvenor Substation
- The remote protection modifications at 3C-Port Hastings
- The modifications to existing Remedial Actions Schemes (RAS).
- Telecommunications equipment supply and installation at 125C-Grosvenor Substation.

IR 618 Goose Harbour Lake FAC - Non-Stand-Alone Network Upgrades										
		Project Number:								
		Cost Centre:		900						
		Labour		Material		Expenses		Contracts	Consulting	Totals
Activity	Accounts -->	535050	535200	531400	530950	533410	533400	531550	532500	
022	Electrical Control Equipment	20,627	5,157	140,000	0	0	0	0		165,783
035	Wood Poles	5,018	0	125,000	0	0	0	375,000		505,018
061	Telephone Equipment (/ Comm Equip.)	16,501	12,376	306,000	0	0	0	400,000		734,877
085	Design (i.e. Engineering)	126,792		1,000	740		500	0	95,000	224,032
086	Commissioning	20,627	0	0	3,000	0	0	0		23,627
087	Field Supervision and Operations	13,658	0	0	2,220		1,500	30,000		47,378
088	Survey and Mapping	0		0	0		0	0	10,000	10,000
Sub-Total		203,223	17,533	572,000	5,960	0	2,000	805,000	105,000	1,710,715
085	Contingency	20,322	1,753	57,200	596	0	200	80,500	10,500	171,072
Sub-Total		223,545	19,286	629,200	6,556	0	2,200	885,500	115,500	1,881,787
005	Vehicle Allocation (Labour & Eng'g)				81,473					81,473
005	Construction Overhead (Labour)							147,488		147,488
005	Construction Overhead (Contracts)							141,737		141,737
Sub-Total					81,473			289,225		370,699
Total		223,545	19,286	629,200	88,029	0	2,200	1,174,725	115,500	2,252,485

Non-Stand-Alone TPIF

- The revenue meter, NSPI's L-7025 protection and control equipment, remote terminal unit (RTU), and telecommunications equipment required at 126C-Goose Harbour Lake Wind substation.

IR 618 Goose Harbour Lake FAC - Non-Stand-Alone TPIF										
		Project Number:								
		Cost Centre:		900						
		Labour		Material		Expenses		Contracts	Consulting	Totals
Activity	Accounts -->	535050	535200	531400	530950	533410	533400	531550	532500	
022	Electrical Control Equipment	51,566	5,157	210,000	0	0	0	0		266,723
061	Telephone Equipment (/ Comm Equip.)	10,313	12,376	286,000	0	0	0	210,000		518,689
085	Design (i.e. Engineering)	79,692		1,000	740		500	0	20,000	101,932
086	Commissioning	20,627	0	0	3,000	0	0	0		23,627
087	Field Supervision and Operations	5,463	0	0	2,220		1,500	25,000		34,183
Sub-Total		167,661	17,533	497,000	5,960	0	2,000	235,000	20,000	945,154
085	Contingency	16,766	1,753	49,700	596	0	200	23,500	2,000	94,515
Sub-Total		184,428	19,286	546,700	6,556	0	2,200	258,500	22,000	1,039,669
005	Vehicle Allocation (Labour & Eng'g)				67,217					67,217
005	Construction Overhead (Labour)							121,680		121,680
005	Construction Overhead (Contracts)							41,377		41,377
Sub-Total					67,217			163,056		230,273
Total		184,428	19,286	546,700	73,773	0	2,200	421,556	22,000	1,269,942

Facilities Study Report

IR-618 - Goose Harbour Lake Wind



Appendix G – Preliminary Project Schedule

Note: Primary Equipment supply chain volatility may introduce significant and unpredictable procurement timelines to the overall project schedule.

Goose Harbour Lake Transmission Interconnection - Preliminary Schedule

Activity	month	Q1 2023			Q2 2023			Q3 2023			Q4 2023			Q1 2024			Q2 2024			Q3 2024			Q4 2024			Q1 2025			Q2 2025			Q3 2025			Q4 2025					
		1	2	3	4	5	6	7	8	9	10	11	12	13	14	15	16	17	18	19	20	21	22	23	24	25	26	27	28	29	30	31	32	33	34	35	36			
Project Administration																																								
Interconnection Agreement In Place																																								
Facilities Study																																								
Design Reviews																																								
Construction Reviews																																								
Handing Over of Assets																																								
Land Agreements & Permits																																								
NSPI Easement Agreements																																								
Interconnection Substation 125C																																								
Design																																								
Procurement																																								
Construction																																								
Site Preparation and Clearing																																								
Civil Works and Foundations																																								
Structures and Primary Equipment																																								
Control Building / Cabling																																								
Commissioning																																								
In-Service Target																																								
Transmission Line L-7025																																								
Design																																								
Procurement																																								
Construction																																								
Clearing																																								
Structures and Conductor Stringing																																								
In-Service Target																																								
L-7003 Line Tap																																								
Design																																								
Procurement																																								
Construction																																								
L-7003 Planned Outage Window																																								
Tap Structures and Conductor Stringing																																								
In-Service Target																																								
Customer Substation 126C																																								
NSPI P&C and Comms. Equip																																								
Design																																								
Procure																																								
Installation																																								
Revenue Meter Install																																								
Substation In-Service Target																																								
Remote Protection & RAS Mods.																																								
3C Protection Mods.																																								
Design																																								
Field Mods.																																								
RAS Mods.																																								
Design																																								
Field Mods.																																								
Commissioning																																								
First Power Available																																								
Commercial Operation																																								

Facilities Study Report

IR-618 - Goose Harbour Lake Wind



Appendix H – Revenue Metering

NSPI Standards 5.7 and 5.12

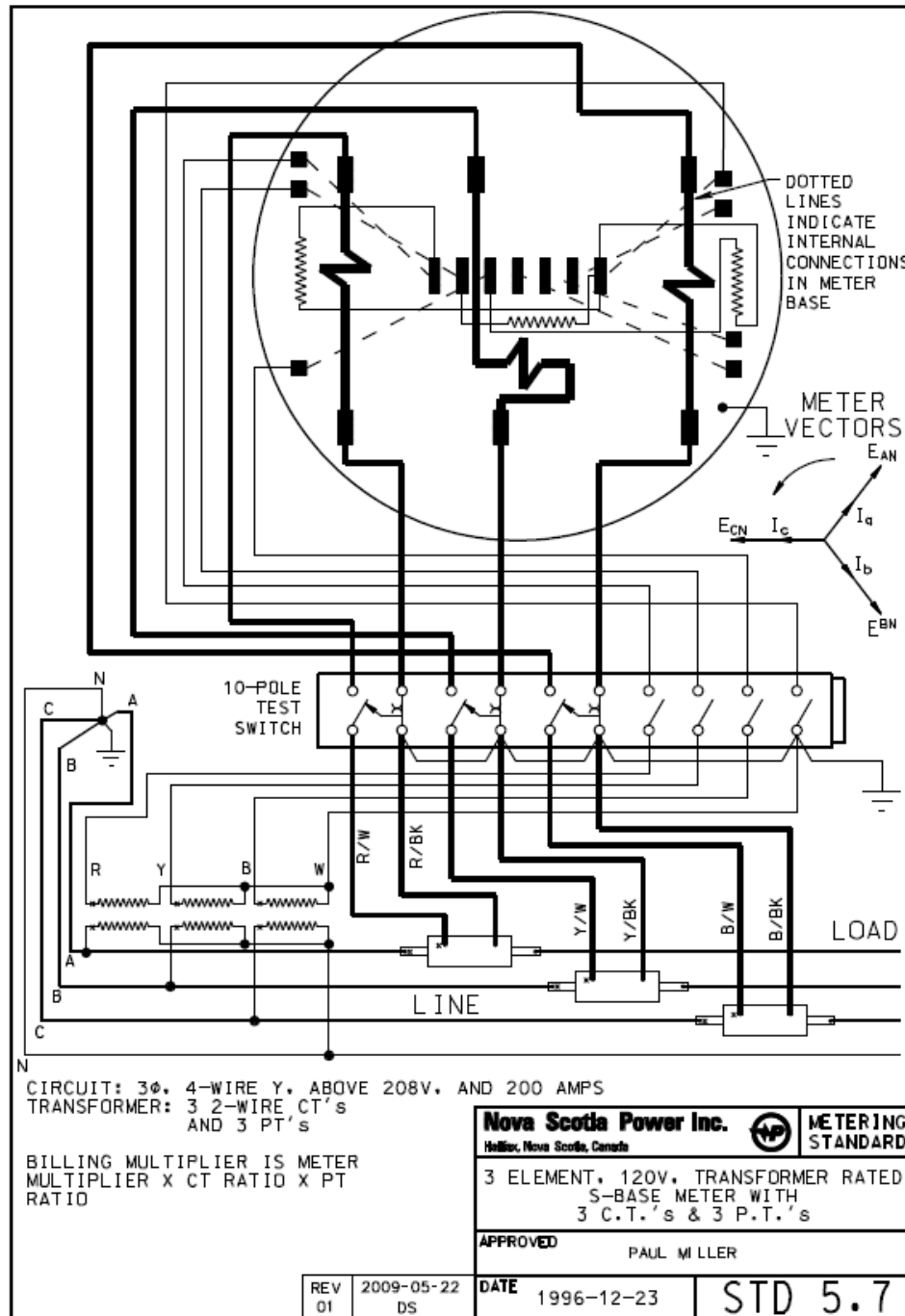

Facilities Study Report

IR-618 - Goose Harbour Lake Wind

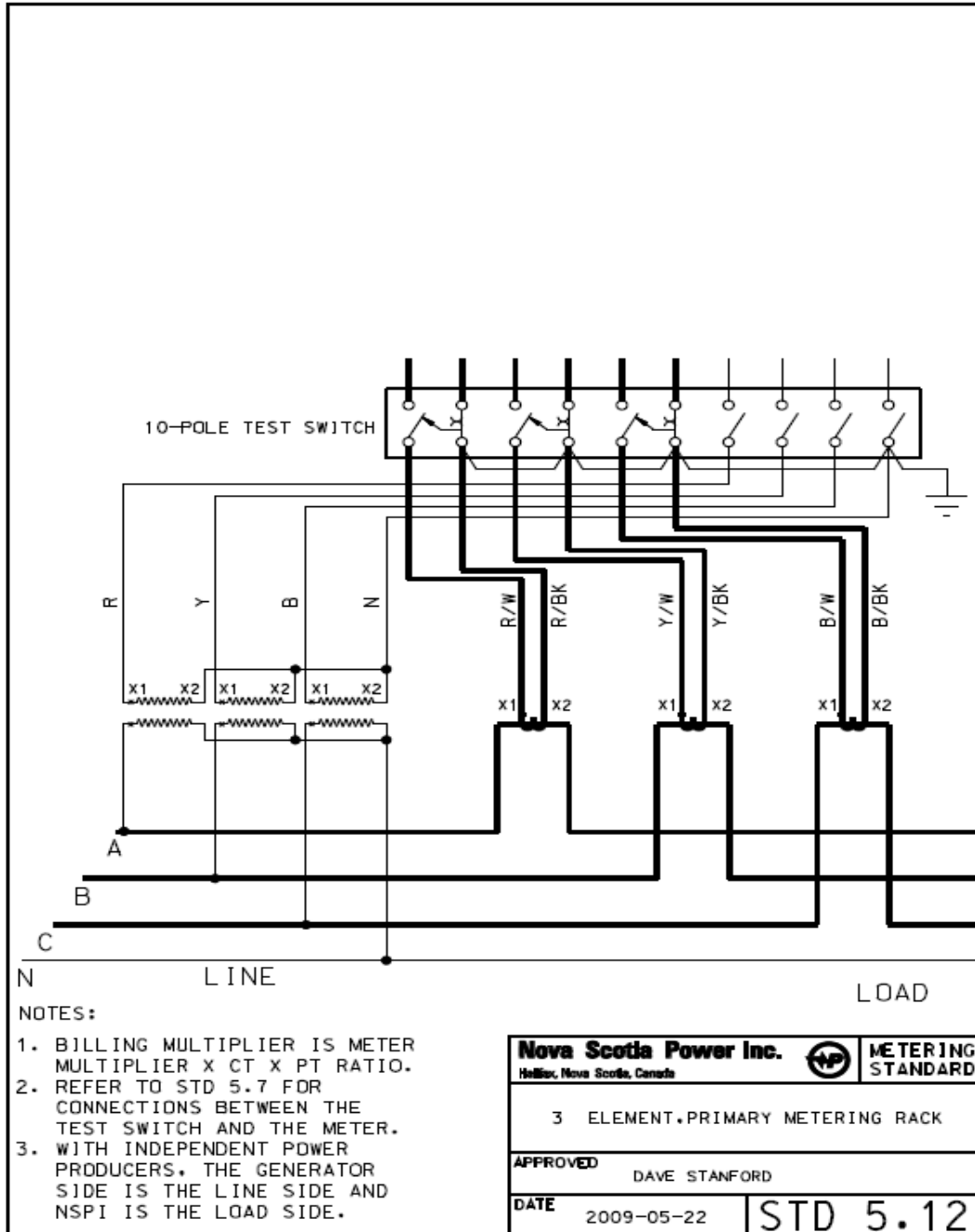

Facilities Study Report

IR-618 - Goose Harbour Lake Wind



Appendix I – 126C-Goose Harbour Lake Wind Terminal Station One Line

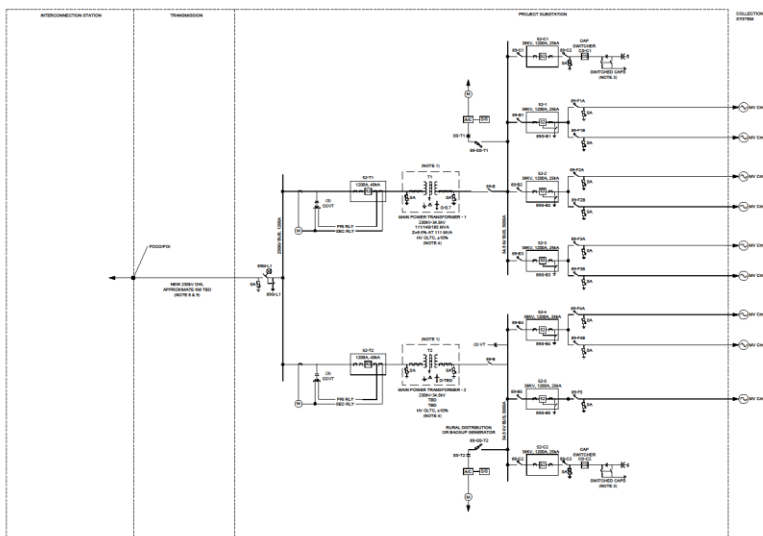

- LEGEND:**
- 5 MW WIND TURBINES
PHASE 1 = 27 TURBINES
PHASE 2 = 14 TURBINES
 - METERING
 - AUTOMATIC CHANGEOVER UNIT
 - LOW VOLTAGE STATION SERVICES
 - FUSED DISCONNECT SWITCH WITH HOOK STICK
 - MOTORIZED DISCONNECT SWITCH
 - MANUAL DISCONNECT SWITCH
 - HOOK STICK DISCONNECT SWITCH
 - CURRENT TRANSFORMER
 - SURGE ARRESTER
 - COUPLED CAPACITOR VOLTAGE TRANSFORMER (CCVT)
 - CIRCUIT BREAKER
 - GWS SWITCHER
 - GROUNDING SWITCH
 - STATION SERVICE TRANSFORMER
 - NORMALLY OPEN, WITH INTERLOCKS
 - VOLTAGE TRANSFORMER
 - SURGE ARRESTER
 - DISCONNECT SWITCH
 - CIRCUIT BREAKER
 - GROUNDING SWITCH
 - MOTOR OPERATED GAND DISCONNECT SWITCH
 - GWS SWITCHER
 - POINT OF CHANGE OF OWNERSHIP
 - POINT OF INTERCONNECTION

- NOTES:**
1. MAIN TRANSFORMER SHALL BE 3-PHASE, 3-WINDING. FINAL RATINGS TO BE DETERMINED DURING DETAILED DESIGN.
 2. CAP BANK SIZES TO BE DETERMINED DURING DETAILED DESIGN.
 3. NEUTRAL GROUNDING REACTOR (NGR) RATINGS AND REQUIREMENTS TO BE DETERMINED DURING DETAILED DESIGN.
 4. HIGH SPEED GROUNDING SWITCH (HSGS) RATINGS AND LOCATION TO BE DETERMINED DURING DETAILED DESIGN.
 5. MEDIUM VOLTAGE SYSTEM SHOWN AS OUTDOOR DESIGN.
 6. CIRCUIT BREAKER RATINGS TO BE DETERMINED DURING DETAILED DESIGN.
 7. INTERCONNECTION OVER HEAD LINE LENGTH TO BE DETERMINED DURING DETAILED DESIGN.
 8. TRANSMISSION LINE CONDUCTOR TO BE DETERMINED DURING DETAILED DESIGN.
 9. RELAYING AND PROTECTION SHOWN ON THIS DRAWING ARE FOR REFERENCE ONLY. FINAL RELAYING AND PROTECTION SCHEME TO BE DETERMINED DURING DETAILED DESIGN.
 11. PROPOSED TRANSMISSION POI AS T-TAP POINT ON EXISTING 230KV UTILITY LINE TO BE CONFIRMED DURING DETAILED DESIGN.

10% DESIGN PLANS

NO.	REV.	DATE	DESCRIPTION
1	01	2021-01-20	ISSUED FOR PERIODIC REVIEW
2	02	2021-02-15	ISSUED FOR INFORMATION
3	03	2021-03-10	ISSUED FOR INFORMATION
4	04	2021-04-05	ISSUED FOR INFORMATION
5	05	2021-05-01	ISSUED FOR INFORMATION
6	06	2021-06-01	ISSUED FOR INFORMATION
7	07	2021-07-01	ISSUED FOR INFORMATION
8	08	2021-08-01	ISSUED FOR INFORMATION
9	09	2021-09-01	ISSUED FOR INFORMATION
10	10	2021-10-01	ISSUED FOR INFORMATION
11	11	2021-11-01	ISSUED FOR INFORMATION
12	12	2021-12-01	ISSUED FOR INFORMATION



FOR REVIEW AND COMMENT ONLY
INFORMATION SHOWN IS SUBJECT TO
CHANGE. NOT FOR CONSTRUCTION.

PORT HAWKESBURY PAPER WIND PROJECT NOVA SCOTIA, CANADA	
SUBSTATION INTERCONNECTION (PH I & II) SINGLE LINE DIAGRAM	
230KV INTERCONNECTION	
PROJECT NO.	21322-RES-SUB-DR-EE-010
SHEET NO.	B

Facilities Study Report

IR-618 - Goose Harbour Lake Wind



Appendix J – Transmission Line (L-7025) Basis of Design

(Attachment 2)

Facilities Study Report

IR-618 - Goose Harbour Lake Wind



Appendix K - Proposed Transmission Line Routing for L-7025

Note: Option A is the Chosen Route

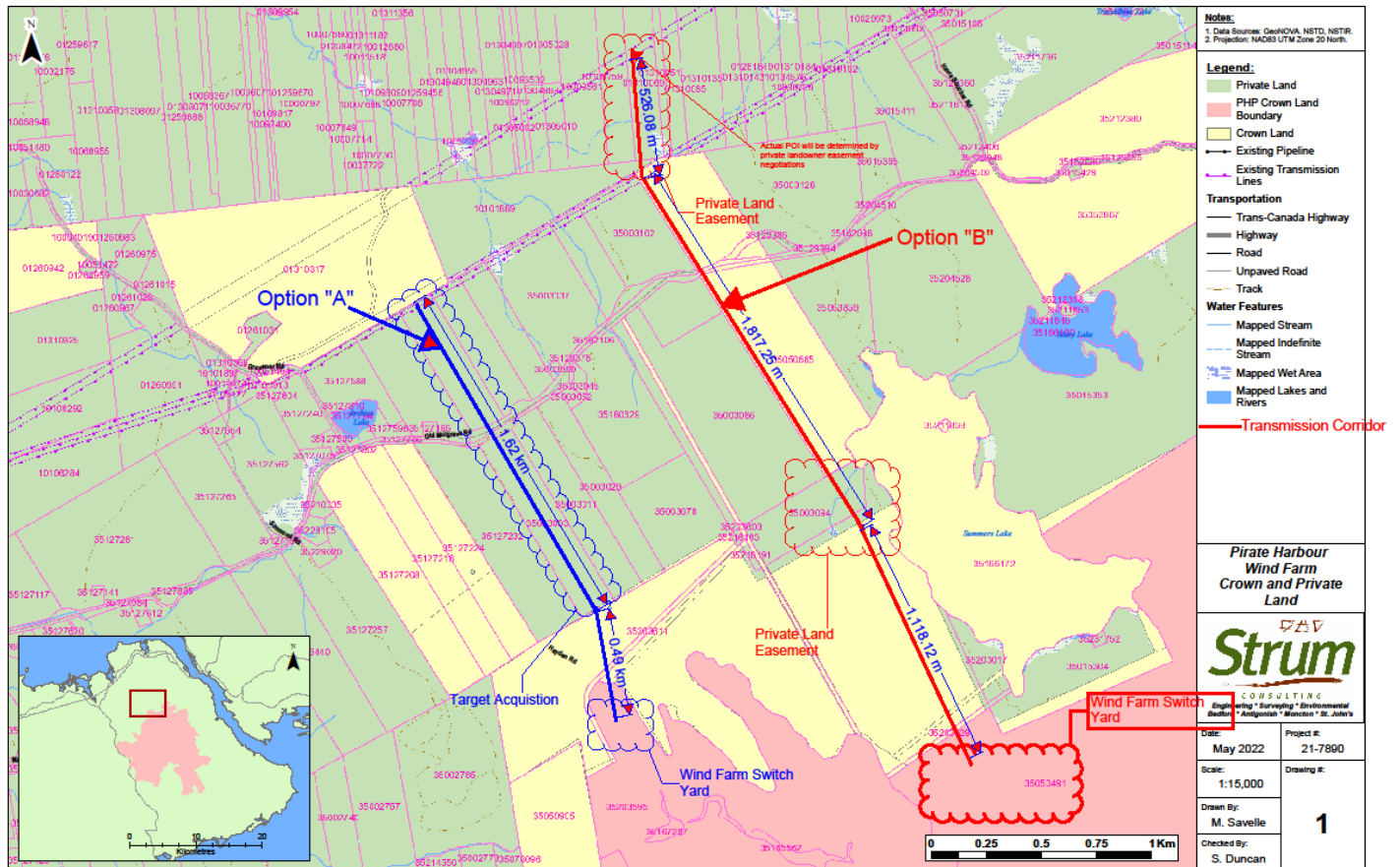

Facilities Study Report

IR-618 - Goose Harbour Lake Wind



Appendix L – Minutes of Facilities Study Review Meeting

Notes:

- Attendees: Timothy Leopold, Mark Savory, Mohit Agarwal
- Introductions
- Review of questions provided by the Interconnection Customer (IC) on the draft Facilities Study (FAC):
- N/A ○
- Next steps: GIA in accordance with GIP ○