



Interconnection Feasibility Study Report

GIP-IR718-FEAS-R1

Generator Interconnection Request 718
149.6 MW Wind Generating Facility
Yellow Birch Wind, NS

2024-05-31

Control Centre Operations
Nova Scotia Power Inc.

Executive Summary

The Interconnection Customer (IC) submitted a Network Resource Interconnection Service (NRIS) and Energy Resource Interconnection Service (ERIS) Interconnection Request (IR#718) for a proposed 149.6 MW wind generation facility interconnected to the NSPI Transmission System, with a Commercial Operation Date of 2027-12-31. The Point of Interconnection (POI) requested by the customer is the 230 kV line L-7027 (existing line is named L-7005), approximately 70 km from 3C-Port Hastings substation.

There are twenty-two (22) transmission Interconnection Requests in the Advanced Stage Transmission and Distribution Queue that must be included in the study models for IR#718.

This study assumes that the addition of generation from IR#718 will displace coal-fired generation in eastern Nova Scotia for both NRIS and ERIS.

Interconnection on L-7027 will require a three-breaker 230 kV ring bus since L-7027 is classified as a Bulk Power System (BPS) element. As IR#718 has dispersed generation totaling more than 75 MVA, each generator will be classified as a NERC BES element. The IR#718 Interconnection Customer substation is also classified as part of the BES, subject to the applicable NERC Reliability Criteria.

The assessment of the POI on the 230 kV line L-7027 indicated that no violations for thermal or voltage criteria were found for IR#718. The location of the POI on L-7027 requires modification to existing RAS (Group 3) to account for the fact that the POI would create two separate circuits. This modified RAS is subject to approval by NPCC.

Data provided by the IC indicates that IR#718 will be utilizing the Nordex Delta4000 - N163/6.X wind turbines. Based on supplied interconnection data and assumptions, IR#718 may not meet the net power factor requirement of +0.95 at the high voltage side of Interconnection Facility. The adequacy of reactive power supply will be further investigated in the System Impact Study as specific details of the collector circuits become available.

NS Power notes that NERC standard PRC-029-1 is currently in development. As proposed, this standard will impose performance requirements for voltage and frequency ride through behaviour on inverter-based generating resources. It is anticipated that this standard will be applicable to the project currently under study. The Interconnection Customer is advised to consider the requirements of PRC-029-1 in their project design to ensure that their project can conform to these requirements. Conformance will be validated at the System Impact Study stage.

IR#718 was not found to adversely impact the short-circuit capabilities of existing circuit breakers. The short circuit level at the Interconnection Facility 34.5 kV bus is 687 MVA with all lines in service and IR#718 off-line, resulting in a 3.7 Short Circuit Ratio (SCR). This falls to 438 MVA with L-7027 open at 3C-Port Hastings, resulting in a SCR of 2.9. These conditions should be discussed with the wind turbine manufacturer to determine if the equipment can operate, or if modifications are required. NSPI system short circuit level may decline over time with changes to transmission configuration and generation mix, as noted in TSIR section 7.4.15. IR#718 must be able to accommodate these changes.

The largest calculated voltage flicker $P_{st}=P_{lt}$ of 0.125 for continuous operation does not exceed NSPI's required limit with L-7027 open at the 3C-Port Hastings end. The project design must meet NSPI requirements for low-voltage ride-through and voltage control. Harmonics must meet the Total Harmonics Distortion provisions of IEEE 519.

The preliminary value for the unit loss factor is calculated as +8.0% at the POI on L-7027, net of any losses on the IC facilities up to the POI.

To connect IR#718 as NRIS & ERIS, the preliminary non-binding cost estimate for interconnecting 149.6 MW to the L-7027 POI is \$13,316,875. This cost estimate includes:

- A three-breaker ring bus substation at the POI.
- 0.075 km (estimated length) 230 kV spur line from the POI to the Interconnection Customer's Interconnection Facility (ICIF).
- Modifications to arming values of existing Group 3 Limited Impact RAS, subject to NPCC approval.

This cost estimate assumes the modifications to existing RAS will be approved by NPCC and includes a 25% contingency. In this estimate, \$9,400,000 (plus 25% contingency) of the amount represents Network Upgrade costs which are funded by the Interconnection Customer, but which are eligible for refund under the terms of the GIP. The remainder of the costs are fully funded by the Interconnection Customer.

The preliminary cost estimate does not include any supplemental equipment that may be required to meet the NSPI power factor and/or inertia requirements. It also does not include costs to address any potential stability issues identified at the SIS stage based on dynamic analysis, costs related to findings of the electromagnetic transient (EMT) analysis, and it assumes that RAS modifications are approved by NPCC.

The estimated time to construct the Transmission Providers Interconnection Facilities and any Network Upgrades is 24-36 months after receipt of funds and cleared right of way from the customer. These estimates will be further refined in the System Impact Study and the Facility Study.

Table of Contents

	Page
Executive Summary	ii
1 Introduction	1
2 Scope	3
3 Assumptions	4
4 Projects with Higher Queue Positions	6
5 Short-Circuit Duty / Short Circuit Ratio	7
6 Voltage Flicker and Harmonics	8
7 Load Flow Analysis	9
8 Reactive Power and Voltage Control	14
9 Bulk Electric / Bulk Power Analysis	16
10 Expected Facilities Required for Interconnection.....	17
11 NSPI Interconnection Facilities and Network Upgrades Cost Estimate	19
12 Loss Factor	20
13 Preliminary Scope of Subsequent SIS.....	20

1 Introduction

This Feasibility Study report (FEAS) presents the results of a Feasibility Study Agreement for the connection of “Yellow Birch Wind” with a capacity of 149.6 MW. This wind generation facility interconnected to NSPI system as Network Resource Interconnection Service (NRIS) and Energy Resource Interconnection Service (ERIS).

This project is listed as Interconnection Request #718 in the NSPI Interconnection Request Queue and will be referred to as IR#718 throughout this report. Interconnection Customer (IC) identified L-7027¹ as the Point of Interconnection (POI), 70 km from 3C-Port Hastings substation. This wind generation facility will be connected to the POI via a 0.075 km long 230 kV transmission line from the Point of Change of Ownership (PCO). Figure 1 shows the approximate geographic location of the proposed POI (red circle) and Figure 2 shows the approximate electrical location (red circle).

Figure 1: Approximate geographic location of IR#718

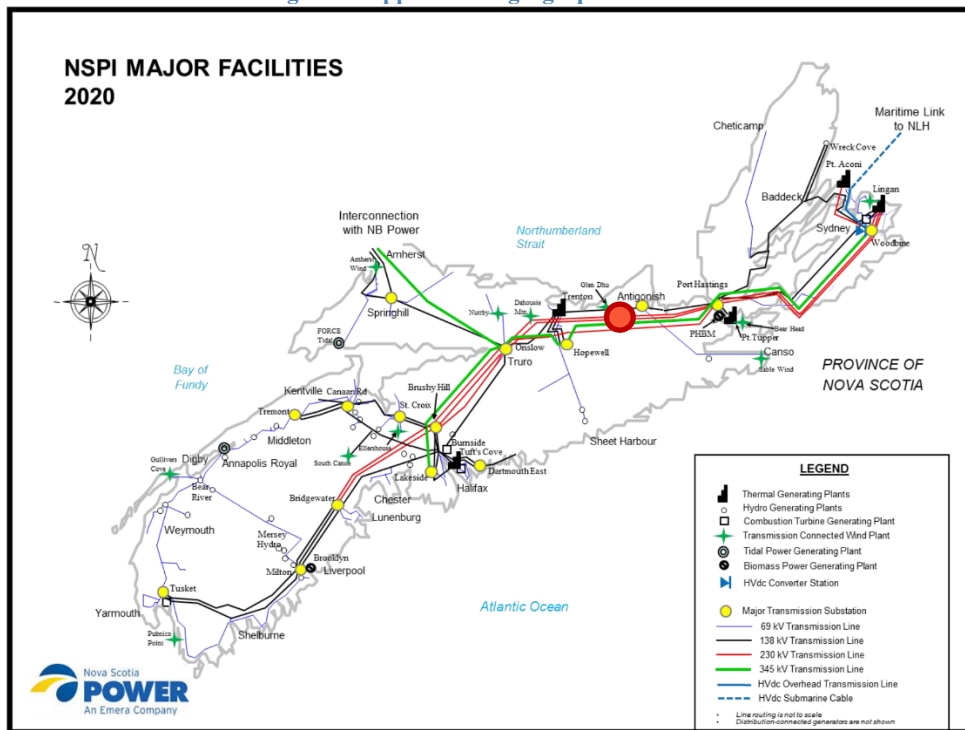

¹ The Designation of Point of Interconnection in the Interconnection Feasibility Study Agreement was L-7005. However, after connecting IR#670, the line at the POI where IR#718 is connected is renamed to L-7027.

Figure 2: Approximate electrical location of IR#718

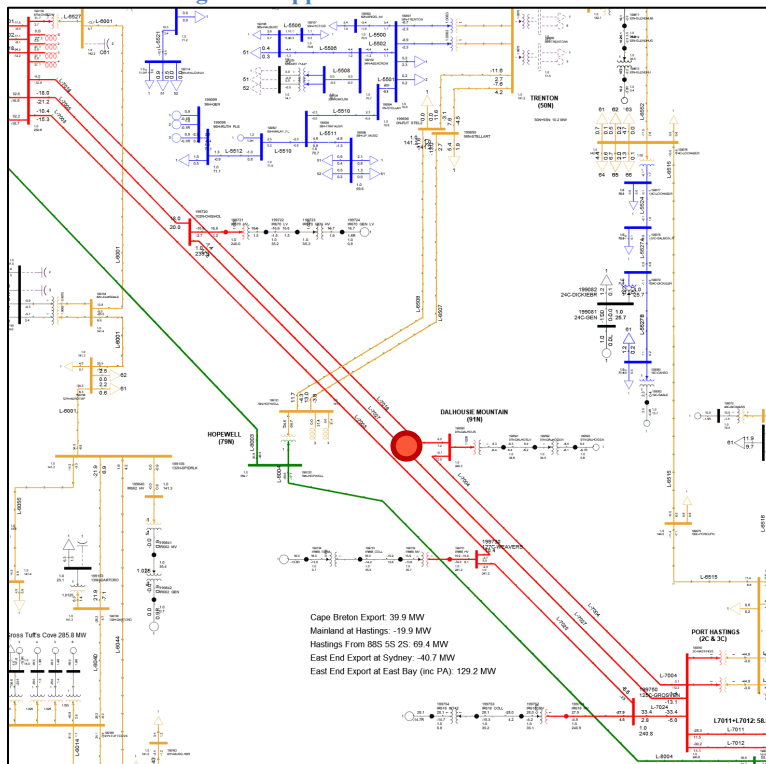

2 Scope

The objective of this FEAS is to provide a preliminary evaluation of system impacts from interconnecting the proposed generation facility to the NSPI transmission system at the requested location. The assessment will identify potential impacts on transmission element loading, which must remain within their thermal limits. Any potential violations of voltage criteria will be identified and addressed. If the proposed generation increases the short-circuit duty of any existing circuit breakers beyond their rated capacity, the circuit breakers must be upgraded. Single contingency criteria are applied.

The scope of the FEAS includes the modeling of the power system in normal state (with all transmission elements in service) under anticipated load and generation dispatch conditions. A power flow and short circuit analysis is performed to provide the following information.

- Preliminary identification of any circuit breaker short circuit capability limits exceeded as a result of the interconnection, and any network upgrades necessary to address the short circuit issue associated with IR#718. Expected minimum short circuit capability will also be identified for the purpose of Short Circuit Ratio analysis.
- Preliminary identification of any thermal overload or voltage violations resulting from the interconnection and identification of the necessary network upgrades to allow full output of the proposed facility. Thermal limits are applied to the seasonal (summer/winter) emergency ratings of the transmission elements. Voltage violations occur when the post-contingency transmission bus voltage is outside the range of +/- 10% of the nominal voltage.
- Preliminary analysis of the ability of the proposed Interconnection Facility to meet the reactive power, power quality and cold-weather capability requirements of the NSPI Transmission System Interconnection Requirements² (TSIR).
- Preliminary description and high-level non-binding estimated cost and time to construct the facilities required to interconnect the generating facility to the transmission system.
- For comparative purposes, the impact of IR#718 on incremental losses under standardized operating conditions is examined.

This FEAS is based on a power flow and short circuit analysis and does not include a complete determination of facility changes/additions required to increase the system transfer capabilities that may be required to meet the design and operating criteria established by NSPI, the Northeast Power Coordinating Council (NPCC), and the North American Electric Reliability Corporation (NERC). These requirements will be determined by a more detailed analysis in the subsequent interconnection System Impact Study (SIS). An Interconnection Facilities Study (FAC) follows the SIS to ascertain the final cost estimate to the interconnect the generating facility.

² [transmission-system-interconnection-requirements \(nspower.ca\)](http://transmission-system-interconnection-requirements (nspower.ca))

3 Assumptions

This FEAS is based on the technical information provided by the IC. The POI and configuration are studied as follows.

1. NRIS and ERIS per section 3.2 of the Generation Interconnection Procedure (GIP).
2. Commercial operation date: 2027-12-31.
3. The Interconnection Customer Facility (ICIF) consists of 22 Nordex Delta 4000 (N163/6.X) wind turbine generators (WTG), each rated 6.8 MW (149.6 MW total) connected to four collector circuits operating at voltage of 34.5 kV.
4. The POI on L-7027 is categorized Bulk Power System and will therefore require three-breaker ring bus in accordance with Table 8 of the TSIR.
5. The ICIF will require the construction of an estimated 0.075 km 230 kV transmission spur line from the POI to the IC 230/34.5kV transformers. The IC will be responsible for providing the applicable Right-of-Way. Due to the short length of the line, the line was modeled as a zero-impedance line.
6. The generation technology used must meet NSPI requirements for reactive power capability of at least 0.95 capacitive to 0.95 inductive at the HV terminals of the IC substation step up transformer. It is also required to have high-speed Automatic Voltage Regulation to maintain constant voltage at the designated voltage control point during and following system disturbances as determined in the subsequent System Impact Study. The designated voltage control point will either be the low voltage terminals of the wind farm transformer, or if the high voltage terminals are used, equipped with droop compensation controls. It is assumed that the generating units are not de-rated in their MW capability when delivering the required reactive power to the system. The IC has indicated that Nordex Delta4000 (N163) has a nominal power factor range from 0.88 capacitive to 0.90 inductive on the LV terminals of the GSU transformer.
7. Preliminary data was provided by the IC for the IC substation interconnection facility. The transformer was rated at 99/132/165 MVA and modeled with a positive-sequence impedance of 9.25% on 99 MVA with an X/R ratio of 50. The IC indicated this interconnection facility transformer has a wye-delta winding configuration with +/-10% on-load tap changer. The impedance of each generator step-up transformer was modeled as 9% on 7.8 MVA with an assumed X/R ratio of 9.19.
8. Detailed collector circuit data was not provided, so typical data ($R+jX = 0.01+j0.04$ pu, with 0.099 pu charging susceptance on system base 100 MVA) was assumed with the understanding that the net real and reactive power output of the plant will be impacted by losses through transformers and collector circuits.

Control Centre Operations – Interconnection Feasibility Study Report

9. Generation Interconnection Queue and OATT Transmission Service Queue that have completed a System Impact Study, or that have a System Impact Study in progress will proceed, as listed in Section 4 below.
10. It is required that the wind turbines are equipped with a “cold weather option” suitable for delivering full power under expected Nova Scotia winter environmental conditions according to section 7.6.9 of the TSIR.
11. Planning criteria meeting NERC Standard TPL-001-5 Transmission System Planning Performance Requirements and NPCC Directory 1 Design and Operation of the Bulk Power System as approved for use in Nova Scotia by the Utility and Review Board, are used in evaluation of the impact of any facility on the Bulk Electric System.
12. L-7027 is a 230 kV circuit between 3C-Port Hastings and 102N/IR670 (6.5 km from 67N-Onslow) and is comprised of multiple sections with various conductors and structure designs as shown in Table 1. The POI for IR#718 is located on the line section labelled “RR Crossing Str#123 to Strait of Canso” which uses 1113.0 kcmil Beaumont ACSR with Gulfport wood pole structures, and is limited to an operating temperature of 70°C.

Section	Length (km)	Conductor	Size	Type	Structure
Onslow to RR Crossing Str#123	25.28	Beaumont	1113.0	ACSR	Gulfport
RR Crossing Str#123 to Strait of Canso	129.43	Beaumont	1113.0	ACSR	Gulfport
Strait of Canso Crossing	1.48	AACSR 900/510	1779.0	AACSR	Double Circuit Four Leg
Strait of Canso to Pt. Hastings 3C	3.10	Beaumont	1113.0	ACSR	Gulfport

13. The rating of transmission facilities in the vicinity of IR#718 are shown in Table 2.

Line	Conductor	Design Temp	Limiting Element	Summer Rating Normal/Emergency	Winter Rating Normal/Emergency
L-6503	1113 Beaumont	85°C	Conductor/ Switchgear/ Breaker/ CT Relaying	287/316 MVA	287/316 MVA
L-6511	556.5 Dove	60°C	Conductor	140/154 MVA	184/202 MVA
L-6552	556.5 Dove	50°C	Conductor/ Switchgear	110/121 MVA	143/157 MVA
L-6515	556.5 Dove	50°C	Conductor/ Switchgear	110/121 MVA	143/157 MVA
L-7003	556.5 Dove	60°C	Conductor	275/303 MVA	348/383 MVA
L-7004	556.5 Dove	60°C	Conductor	233/256 MVA	307/338 MVA
L-7019	556.5 Dove	70°C	Conductor	273/300 MVA	345/380 MVA
L-7005	1113 Beaumont	70°C	CT Relaying	398/398MVA	398/398MVA
L-7027	1113 Beaumont	70°C	CT Relaying	398/398MVA	398/398MVA

4 Projects with Higher Queue Positions

All in-service generation is included in the FEAS, except for Lingan Unit 2, which is assumed to be retired.

As of 2024/02/15, the following projects are higher queued in the Advanced Stage Interconnection Request Queue and are committed to the study base cases:

- IR426: GIA Executed
- IR516: GIA Executed
- IR540: GIA Executed
- IR542: GIA Executed
- IR517: GIA in Progress
- IR574: GIA Executed
- IR598: GIA Executed
- IR597: GIA Executed
- IR647: GIA in Progress
- IR664: FAC Complete
- IR662: FAC Complete
- IR670: FAC Complete
- IR671: FAC in Progress
- IR669: FAC Complete
- IR668: FAC Complete
- IR618: FAC Complete
- IR673: FAC Complete
- IR675: FAC Complete
- IR677: SIS in Progress
- IR697: SIS in Progress
- IR739: SIS in Progress
- IR742: SIS in Progress

The power system base cases for the feasibility study include all transmission connected IRs in the GIP queue up to and including IR742 with the exception of IR686, as the IR686 SIS was not completed when IR718 was initiated.

In addition, TSR-411 is included in the queue, which reflects the study of long-term firm Transmission Service Reservation (TSR) from New Brunswick to Nova Scotia. If approved by the NSUARB, the TSR is expected to be in service in 2028 and a system study is currently underway to determine the required updates to the Nova Scotia transmission

system. This has not been included in the feasibility study and the following notice is posted to the OASIS site³:

Due to ongoing development discussions and engineering studies, the Transmission System Network Upgrades identified as part of Transmission Service Request #411 will not be included in the System Impact Study (SIS) Analysis for Generator Interconnection Procedures (GIP) Study Groups #32 to #35. GIP Study Group #32 to #35 analysis will be limited to the 2024 Transmission System configuration plus any material Network Upgrades identified in higher queued projects.

5 Short-Circuit Duty / Short Circuit Ratio

The maximum (design) expected short-circuit level is 5,000 MVA (21 kA) on 138 kV systems and 10,000 MVA (25 kA) on 230 kV systems. The fault current characteristics for NORDEX Delta4000 (N163) wind turbine is given as 3.36 times rated current, or $X'd = 0.298$ per unit on machine base MVA.

The short circuit analysis is performed using PSS®E version 34.7 for a classical fault study, 3LG and flat voltage profile at 1.0 pu. The maximum short circuit MVA values calculated for scenarios with and without IR#718 at the POI and one-substation away are compared in Table 3.

Table 3: Short-Circuit Levels. IR#718 (Type 3) on L-7027 Three-phase MVA ⁽¹⁾		
Location	Without IR#618	With IR#618
Maximum Generation Conditions - All transmission facilities in service		
POI on L-7027 (230 kV)	1916	2192
Interconnection Facility (230 kV)	1916	2192
Interconnection Facility (34.5 kV)	687	1060
67N-Onslow (230 kV)	4788	4911
3C-Port Hastings (230 kV)	3956	4090
2C-Port Hastings (138 kV)	3406	3458
Minimum Generation Conditions (TC3, LG1, ML In-Service)		
Interconnection Facility (230 kV), all lines in-service	1146	1423
Interconnection Facility (230 kV), L-7005 open at 67N	758	1034
Interconnection Facility (230 kV), L-7027 open at 3C	742	1019

³ <https://www.nspower.ca/oasis/generation-interconnection-procedures>

Table 3: Short-Circuit Levels. IR#718 (Type 3) on L-7027 Three-phase MVA ⁽¹⁾		
Location	Without IR#618	With IR#618
Maximum Generation Conditions - All transmission facilities in service		
Interconnection Facility (34.5 kV), all lines in-service	554	926
Interconnection Facility (34.5 kV), L-7005 open at 67N	444	817
Interconnection Facility (34.5 kV), L-7027 open at 3C	438	811

(1) Classical fault study, flat voltage profile

The maximum short circuit analysis for the system under normal condition shows that the development of IR#718 will not require upgrades in the local substation breakers.

Inverter-based generation installations often have a minimum Short Circuit Ratio (SCR) for proper operation of converters and control circuits. The minimum short circuit ratio at the 34.5 kV ICIF bus is 3.7 with all lines in service and IR#718 offline. This falls to 3.0 and 2.9 with L-7005 open at 67N-Onslow and L-7027 open at 3C-Post Hastings, respectively.

Documentation supplied by the IC states that a study is needed to optimize the turbine for connections with SCRs between 1.5-3.0. These expected SCR conditions should be discussed with the wind turbine manufacturer to determine if the equipment can operate, or if modifications are required.

NSPI system short circuit level may decline over time with changes to transmission configuration and generation mix. IR#718 must be able to accommodate these changes, per TSIR section 7.4.15. Windfarms in proximity to IR#718 (e.g. 91N, IR#618, IR#668, IR#670) will also reduce the effective SCR in the area. The impact of the low SCR will be further examined when detailed data for the machine is made available for the SIS.

6 Voltage Flicker and Harmonics

The voltage flicker calculations use IEC Standard 61400-21 based on estimated data provided by NORDEX Delta4000 6.8 MW wind turbines (4.0 flicker coefficient $c(\psi_k, v_a)$ at 85° system angle). The flicker step factor $K_f(\psi_k)$ for switching operations at a system angle of 85° is given as 0.2 for start-up at both cut-in wind speed and rated wind speed. The maximum number of switching operations within a 10-minute period (N10m) is given as 1. The maximum number of switching operations within a 120-minute period (N120m) is given as 10 for cut-in speed and 12 for rated wind speed. The voltage flicker P_{st} and P_{lt} levels are calculated at the Interconnection Facility for various system conditions and are shown in Table 4 below.

Table 4: Calculated Voltage Flicker at 230 kV Bus					
System Conditions	P _{st} =P _{lt} Continuous	Switching			
		P _{st}		P _{lt}	
		Cut-in speed	Rated speed	Cut-in speed	Rated speed
Maximum Generation					
All Transmission in Service	0.058	0.029	0.029	0.026	0.028
Minimum Conditions (TC3, LG1, ML In-Service)					
All Transmission in Service	0.090	0.045	0.045	0.041	0.043
L-7005 open at 67N	0.123	0.062	0.062	0.056	0.059
L-7027 open at 3C	0.125	0.062	0.062	0.057	0.060

NSPI’s required limits are 0.35 for P_{st} and 0.25 for P_{lt}. IR#718 is able to meet the flicker requirement in all studied system conditions, including both N-1 minimal generation conditions. This should be further evaluated in the SIS.

The generator is expected to meet IEEE Standard 519-2014 limiting voltage Total Harmonic Distortion (all frequencies) to a maximum of 1.5%, with no individual harmonic exceeding 1.0% on 230 kV.

7 Load Flow Analysis

The load flow analysis was completed for Spring Minimum Load (SML), Summer Shoulder Load (SSH), Summer Peak Load (SUM) and Winter Peak Load (WIN) Scenarios with varying dispatch scenarios intended to cover a broad range of operating conditions.

Table 5 includes the list of base cases considered, along with a brief description.

Table 5: List of Base Cases	
Case Name	Description
SML_01	Spring Minimum Load with low wind (nearby and other WTG at 17%)
SML_02	Spring Minimum Load with high wind (nearby and other WTG at 43% and 17%, respectively)
SSH_01	Summer Shoulder Load with low wind (nearby and other WTG at 17%)
SSH_02	Summer Shoulder Load with high wind (nearby and other WTG at 53% and 17%, respectively)
SUM_01	Summer Peak Load with low wind (nearby and other WTG at 17%)
SUM_02	Summer Peak Load with high wind (nearby and other WTG at 100% and 29%, respectively)
SUM_03	Summer Peak Load with moderate wind (nearby and other WTG at 30%). Wreck Cove dispatched at historical seasonal maximum and with Port Hawkesbury Paper at maximum load.

Control Centre Operations – Interconnection Feasibility Study Report

Table 5: List of Base Cases	
Case Name	Description
SUM_04	Summer Peak Load with low wind (nearby and other WTG at 17%) and with power flow between NS and NB at 320 MW, simulating delivery of reserve to NB. Wreck Cove is dispatched at historical seasonal maximum.
WIN_01	Winter Peak Load with low wind (nearby and other WTG at 17%)
WIN_02	Winter Peak Load with high wind (nearby and other WTG at 100% and 73%, respectively)
WIN_03	Winter Peak Load with high wind (nearby and other WTG at 88%) and with maximum load at Port Hawkesbury Paper.
WIN_04	Winter Peak Load with low wind (nearby and other WTG at 17%) and with power flow between NS and NB at 170 MW, simulating delivery of reserve to NB. This case represents stressed corridors with heavy flow from eastern NS to the load centre.

These 12 base scenarios were studied with and without IR#718. This FEAS added IR#718 and displaced an equivalent amount of existing generation according to dispatch guidelines provided by NSPI⁴. Figure 3 shows the relevant corridors, generators and loads on the NSPI transmission system. The arrow by each corridor shows the power flow direction of positive values.

⁴ Thermal generation was decreased to Pmin based on a merit order provided by NSPI, followed by small hydro units. If further generation was required to be decreased, “other” wind farms (i.e., not “nearby” wind farms that would impact thermal overloads near the IC) were decreased.

Figure 3 Relevant transmission interfaces

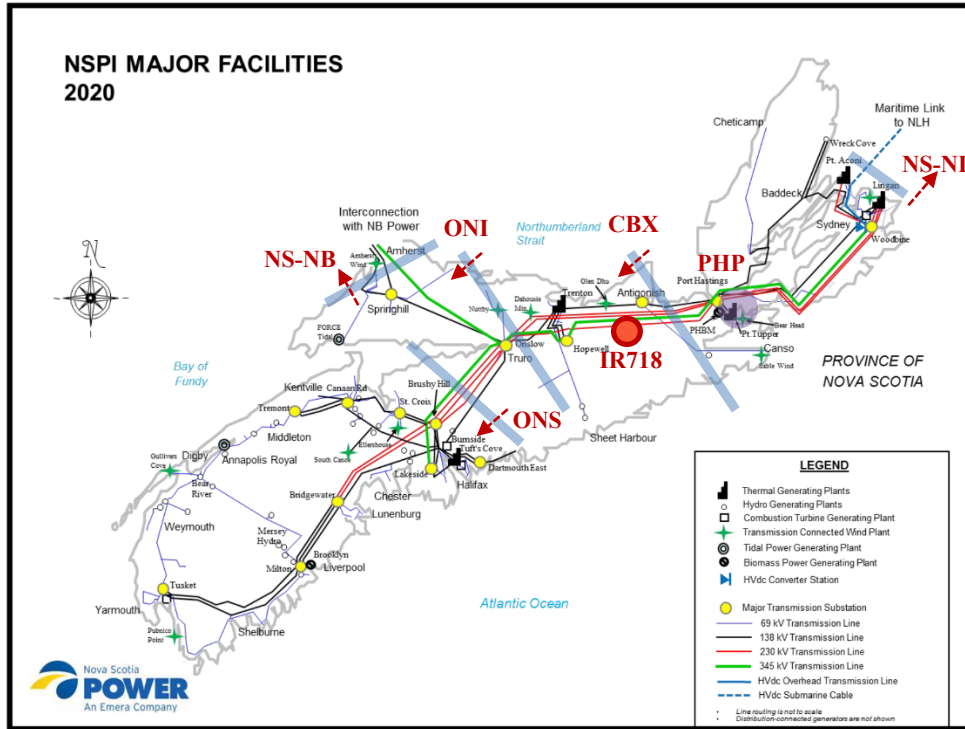

Table 6 summarizes the base cases and the dispatch scenarios to compare the effect of IR#718 on the loading of key NS corridors and generators. The case name followed by 1 (e.g., SML_01-1) stands for the case without IR#718 and the case name followed by 2 (e.g., SML_01-2) stands for the case with IR#718.

Case	NS-Load	NS-NB	NS-NL	ONS	ONI	CBX	PHP	Wind	IR#718
SML_01-1	727	151	-170	-94	68	39	176	236	-
SML_01-2	727	150	-170	24	186	12	176	236	149.6
SML_02-1	759	150	-170	106	268	-19	209	516	-
SML_02-2	759	152	-170	106	270	-25	209	366	149.6
SSH_01-1	1161	151	-330	163	369	291	146	236	-
SSH_01-2	1161	147	-330	261	462	239	146	236	149.6
SSH_02-1	1157	154	-330	415	624	260	146	571	-
SSH_02-2	1157	151	-330	417	623	254	146	416	149.6
SUM_01-1	1545	150	-330	411	659	558	145	236	-
SUM_01-2	1545	150	-330	411	659	411	145	236	149.6
SUM_02-1	1604	151	-330	491	690	284	207	901	-
SUM_02-2	1604	150	-330	603	830	282	207	759	149.6
SUM_03-1	1604	152	-330	596	823	423	207	768	-
SUM_03-2	1604	144	-330	693	934	391	207	658	149.6

Control Centre Operations – Interconnection Feasibility Study Report

Case	NS-Load	NS-NB	NS-NL	ONS	ONI	CBX	PHP	Wind	IR#718
SUM_04-1	1541	323	-475	516	939	852	145	236	-
SUM_04-2	1541	326	-475	516	942	706	145	236	149.6
WIN_01-1	2354	0	-170	855	1040	886	15	236	-
WIN_01-2	2354	0	-170	855	1040	791	15	236	149.6
WIN_02-1	2349	-3	-170	795	851	447	15	1286	-
WIN_02-2	2349	0	-170	903	990	445	15	1147	149.6
WIN_03-1	2545	3	-170	689	741	396	220	1286	-
WIN_03-2	2545	2	-170	689	740	247	220	1286	149.6
WIN_04-1	2354	168	-330	852	1206	1043	15	236	-
WIN_04-2	2354	168	-330	852	1206	968	15	236	149.6

- (1) For inter-area flows, +ve indicates export and -ve indicates import.
- (2) The Wind column accounts only for transmission-connected wind facilities (excluding the IR under study).

Due to the newly introduced wind generation by IR#718, the loading of corridors west to the POI (i.e., Onslow Import - ONI and Onslow South - ONS) has increased and loading of corridors east to the POI (i.e., Cape Breton Export - CBX) has decreased. This is due to the displacement of generation in the east of the province based on the merit order. Inter-provincial power flows between NS-NB are varied in these base cases, but only export conditions are considered in order to assess the impact of IR#718 integration with stressed CBX/ONI corridors.

Single contingencies were applied at the 345 kV, 230 kV, 138 kV and 69 kV voltage levels for the above system conditions with and without IR#718. Automated analysis searched for violations of emergency thermal ratings and emergency voltage limit for each contingency. Contingencies studied are listed in Table 7.

Table 7: Contingency List				
88S_L7014	3C_T72	1N_L6001	103H_881	101V_L6004
88S_L7021	3C_710*	1N_T1	103H_600	101V_601
88S_L7022	3C_711	1N_T4	103H_608	99W_BESS
88S_710	3C_712*	1N_T65	103H_681	43V_BESS
88S_711	3C_713	1N_C61	91H_L5049	132H_BESS
88S_713	3C_714	1N_B61	91H_L5012	99W_708
88S_714	3C_715*	1N_B62	91H_L5041	99W_709
88S_715	3C_716	1N_600	91H_T62	99W_T71
88S_720	2C_L6515	1N_601	91H_T11	99W_T72
88S_721	2C_L6516	1N_613	91H_511	DCT_L5039_L6033
88S_722	2C_L6517	120H_L7008	91H_516	DCT_L7009_L8002
88S_723*	2C_L6518	120H_L7009	91H_521	DCT_L6011_L6010
88S_T71	2C_L6537	120H_L6005	91H_523	DCT_L6010_L6005

Control Centre Operations – Interconnection Feasibility Study Report

Table 7: Contingency List				
88S_T72	2C_B61	120H_L6010	91H_G3	DCT_L6005_L6016
88S_G2	2C_B62	120H_L6011	91H_G4	DCT_L7008_L7009
88S_G3	79N_L8003*	120H_L6051	91H_G5	DCT_L7003_L7004*
88S_G4	79N_L6507	120H_L6016	91H_G6	DCT_L7024_L7004*
101S_ML_POLE1	79N_L6508	120H_T71	14H_GT1	DCT_L6507_L6508
101S_ML_POLE2	79N_T81*	120H_T72	14H_GT3	DCT_L7021_L6534
101S_ML_BIPOLE	67N_L8001*	120H_SVC	83S_GT1	DCT_L6033_L6035
101S_T81	67N_L8002	120H_710	83S_GT2	85S_L6545
101S_T82	67N_L7019	120H_711	85S_GT1	5S_L6538
101S_L7011*	67N_L7001	120H_712	85S_GT2	3S_L6539
101S_L7012*	67N_L7002	120H_713	132H_602	5S_L6537
101S_L7015	67N_L7018	120H_714	132H_603	5S_L6516
101S_L8004*	67N_T81	120H_715	132H_605	5S_606
101S_701	67N_T82	120H_716	132H_606	5S_607
101S_702	67N_T71	120H_720	91N_701	2S_513
101S_703	67N_811*	120H_621	91N_702	89S_G1
101S_704	67N_812	120H_622	91N_703	1C_G2
101S_705	67N_813	120H_623	91N_B71	48C_G1
101S_706	67N_814*	120H_624	125C_L7025	50N_G5
101S_711	67N_701	120H_626	125C_701	50N_G6
101S_712	67N_702	120H_627	125C_B71	104W_G1
101S_713	67N_703	120H_628	127C_L7003	110W_T62
101S_811	67N_704	120H_629	127C_701	104H_600
101S_812*	67N_705	103H_L6008	127C_B71	SALISBURY_L3004
101S_813*	67N_706	103H_L6033	102N_L7005	SALISBURY_L3013
101S_814	67N_710	103H_L6038	102N_701	SALISBURY_SA3_2*
101S_816	67N_711*	103H_T81	102N_B71	SALISBURY_L3006*
3C_L7024	67N_712	103H_T61	100N_L6555	MEMRAMCOOK_L1159
3C_L7004	67N_713	103H_T63	100N_601	MEMRAMCOOK_L1160
3C_L7027*	1N_L6613	103H_B61	100N_B61	MEMRAMCOOK_ME3_1*
3C_T71	1N_L6503	103H_B62	101V_L6054	

Note: Contingencies marked with * denotes applicable in service SPS may be armed.

Based on the steady state contingencies evaluated in this study, it is demonstrated that IR#718 can operate as NRIS and ERIS without violating thermal load or under/over-voltage criteria. The addition of IR#718 does not result in the creation of any new thermal limit/voltage violations, and does not negatively impact any existing thermal limit/voltage violations.

It will be required to upgrade the thermal rating of L-7005/L-7027 by adjusting the current transformer relaying and metering settings. This is not expected to have an associated cost.

8 Reactive Power and Voltage Control

In accordance with TSIR Section 7.6.2, IR#718 must be capable of delivering reactive power for a net power factor of at least +/- 0.95 of rated capacity to the high side of the plant interconnection transformer(s). Reactive power can be provided by continually acting auxiliary devices such as STATCOM, DSTATCOM or synchronous condenser, supplied by the Interconnection Customer. The P-Q diagram for Mode-1 (6800 kW) by Nordex is shown in Figure 4.

Figure 4: P-Q diagram for Mode-1 (6800 kW) by Nordex

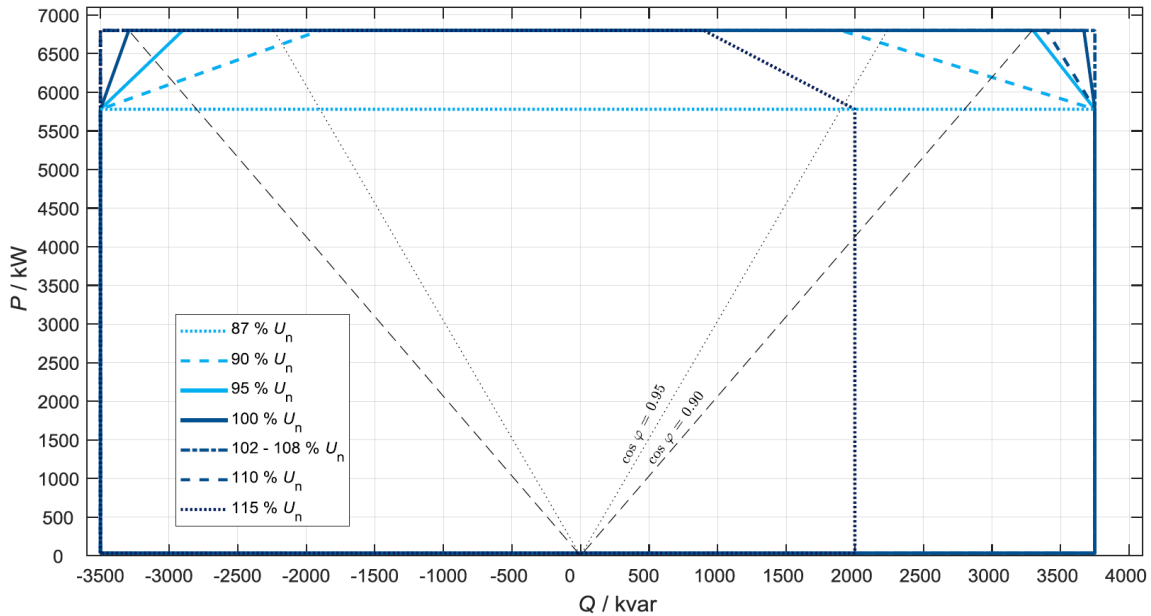

When the active power is zero, the reactive power is zero. The option “STATCOM function” can be added to inject/absorb reactive power when active power is zero at a reduced capacity.

The power factor analysis is conducted using a SMIB (Single Machine Infinite Bus) case for IR#718. The leading power factor analysis for IR#718 results in power factor values less than 0.95. This verifies the ability of the configuration to meet the leading power factor requirement. IR#718 can meet the lagging power factor requirement of 0.95, but this results in a terminal voltage above 1.1 pu, which is outside the capability curve shown in Figure 4. Increasing the plant transformer tap to bring the turbine within its capability (terminal voltage <1.08 pu), a power factor of 0.95 is possible by reducing the active power output down to 96%. Analysis shown in Figure 5 verifies the reactive power capability of the system.

Figure 5: Power Factor Analysis

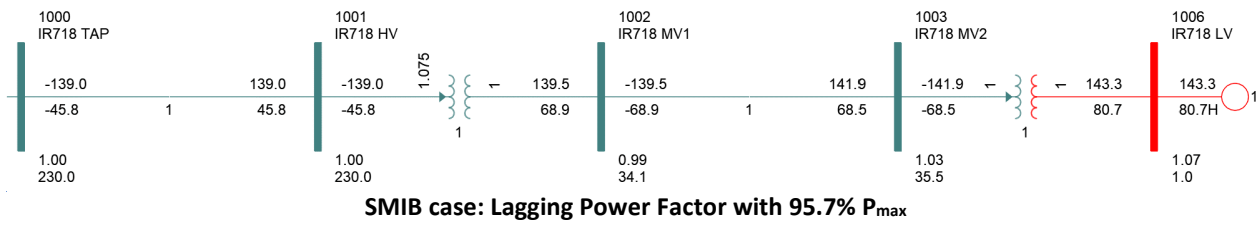
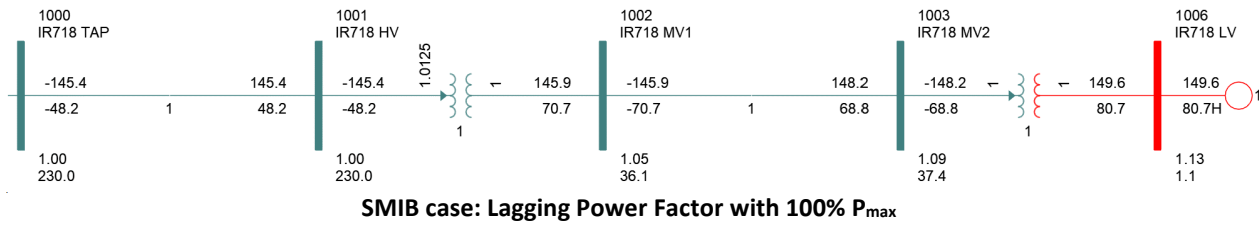
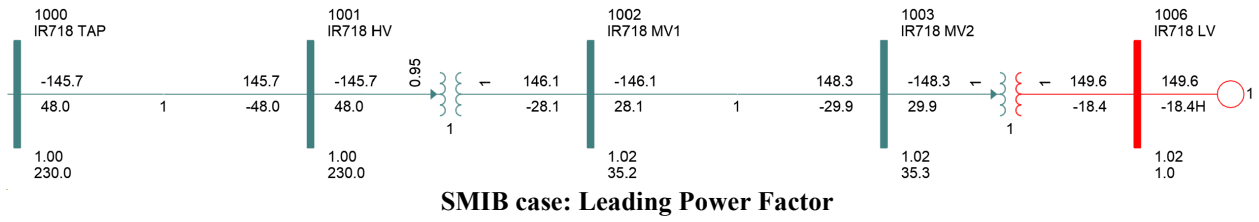

A sensitivity test was performed by adjusting the tap of the GSU. With a tap setting of 1.05, a 0.95 power factor lagging was obtained for 99.5% of P_{max}.

Figure 6: Power Factor Analysis: GSU Tap Adjusted

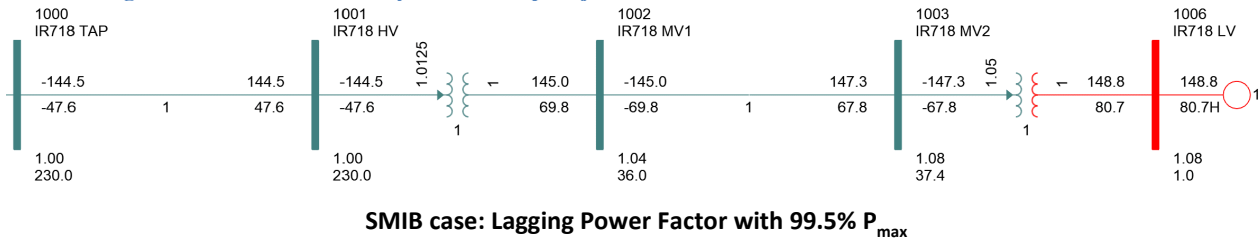

A sensitivity test was performed with the wind turbine operating in STATCOM mode. In STATCOM mode, the reactive power limits are reduced.

Figure 7: Power Factor Analysis: STATCOM Mode

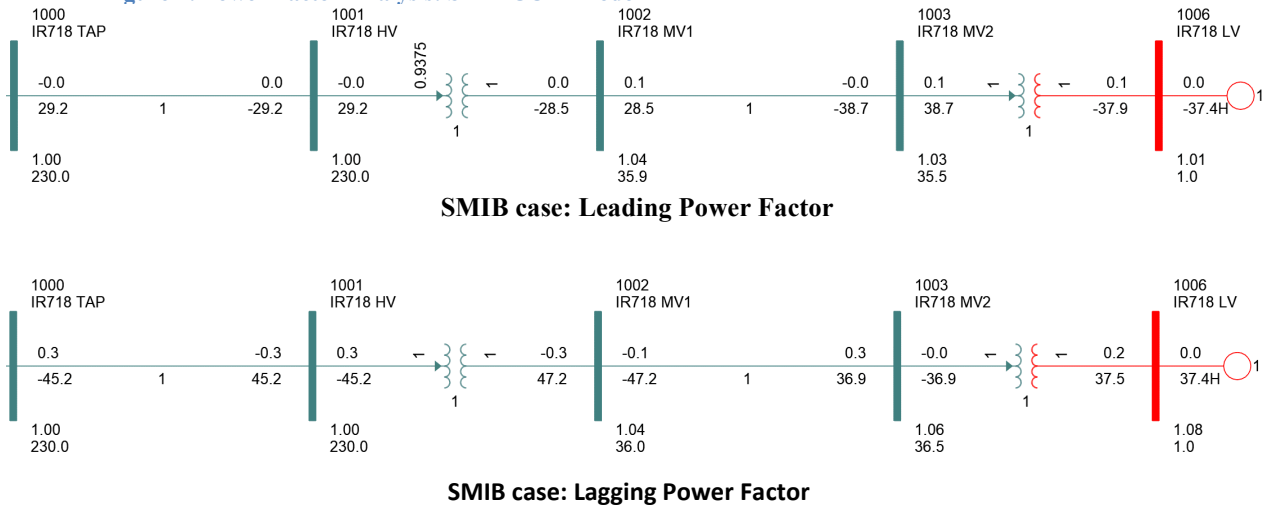

A centralized controller will be required which continuously adjusts individual generator reactive power output within the plant capability limits and regulates the voltage at the 34.5 kV bus voltage. The voltage controls must be responsive to voltage deviations at the terminals of the interconnection facility substation, be equipped with a voltage set-point control, and can slowly adjust the set-point over several (5-10) minutes to maintain reactive power within the individual generator capabilities. The details of the specific control features, control strategy and settings will be reviewed and addressed in the SIS, as will the dynamic performance of the generator and its excitation. Line drop compensation, voltage droop, control of separate switched capacitor banks must be provided.

The NSPI System Operator must have manual and remote control of the voltage set-point and the reactive set-point of this facility to coordinate reactive power dispatch requirements.

This facility must also have low voltage ride-through capability as per Appendix G of the Standard Generator Interconnection and Operating Agreement (GIA). The SIS will state specific options, controls and additional facilities that are required to achieve this.

Settings for the ICIF on-load tap-changer must be coordinated with plant voltage controller for long-term reactive power and voltage management at the POI.

9 Bulk Electric / Bulk Power Analysis

The 230 kV buses at the 67N-Onslow substation and the 3C-Port Hastings substation as well as line L-7027 are part of the NPCC Bulk Power System (BPS). As such, all protection systems associated with the new three-breaker ring bus at the POI must comply with NPCC Directory 4 System Protection Criteria.

Since the 67N-Onslow substation and 3C-Port Hastings substations are currently classified as part of the NERC Bulk Electric System (BES), they are also subject to the applicable NERC Reliability Criteria. As IR#718 has dispersed generation totaling more than 75 MVA, Inclusion I4 of the NERC BES Definition applies; each generator and systems designed for delivering that aggregate capacity to the POI classified are categorized as BES elements.

Line L-7027 presently has RAS installed (Group 3) which will be impacted by the installation of a Transmission Provider Interconnection Facility (TPIF) substation on this circuit. Modifications will be required to account for the fact that the TPIF would create two separate circuits. Complete RAS categorization will be determined further in the GIP process and the modifications will require NPCC approval.

10 Expected Facilities Required for Interconnection

The following facility changes will be required to connect IR#718 to the NSPI transmission system at a POI on L-7027 under NRIS and ERIS:

a. Required Network Upgrades

- Modification of NSPI protection systems at 67N-Onslow and 3C-Port Hastings.
- Install a new 230 kV substation complete with 3 breaker ring bus at the POI on L-7027 with control and protection. A Remote Terminal Unit (RTU) to interface with NSPI's SCADA system, with telemetry and controls as required by NSPI.
- Changes to existing NSPI Limited Impact RAS (Group 3).
- Changes to existing NSPI Type 1 Impact RAS (Group 5 & 6).
- Modifications to L-7005/L-7027 current transformer relaying and metering settings.

b. Required Transmission Provider's Interconnection Facilities (TPIF):

- Construct a 0.075 km (estimated) 230 kV transmission line between the L-7027 POI and the ICIF substation. This line must be built to NSPI's 230 kV standards.
- Supervisory, control, and communications between the wind farm and NSPI SCADA system (to be specified).

c. Required Interconnection Customer's Interconnection Facilities (ICIF)

Control Centre Operations – Interconnection Feasibility Study Report

- Facilities to provide 0.95 leading and lagging power factor when delivering rated output at the HV terminals of the IC Substation Step Up Transformer when the voltage at that point is operating between 95 and 105% of nominal.
- Facilities to meet the requirement that rated reactive power be delivered from zero to full rated real power. Supplemental equipment will be required as noted in Section 8.
- Centralized controls. These will provide centralized voltage set-point controls and are known as Farm Control Units (FCU). The FCU will control the 34.5 kV bus voltage and the reactive output of the machines. Responsive (fast-acting) controls are required. The controls will also include a curtailment scheme which will limit or reduce total output from the facility, upon receipt of a telemetered signal from NSPI's SCADA system.
- NSPI will have control and monitoring of reactive output of this facility, via the centralized controller. This will permit the NSPI Operator to raise or lower the voltage set-point remotely.
- Low voltage ride-through capability per Section 7.4.1 of the TSIR.
- Real-time monitoring (including an RTU) of the interconnection facilities. Local wind speed and direction, MW and MVA_r, as well as bus voltages are required.
- Facilities for NSPI to execute high speed rejection of generation (transfer trip) if determined in SIS. The plant may be incorporated into RAS run-back schemes.
- Automatic Generation Control to assist with tie-line regulation.
- Compliance with section 7.6.7 of TSIR, "WECS Generating Facilities shall support short-duration frequency deviations by providing inertia response equivalent to a Synchronous Generator with an inertia factor (H) of at least 3.0 MW-s/MVA for a period of at least 10 seconds." This item will be assessed in the SIS, which may identify additional resources such as synchronous condenser, Flexible AC Transmission System (FACTS) devices, etc. are required.
- Operation at an ambient temperature of -30°C, section 7.6.9 of the TSIR.
- The facility must meet NSPI's TSIR as published on the NSPI OASIS site.
- NS Power notes that NERC standard PRC-029-1 is currently in development. As proposed, this standard will impose performance requirements for voltage and frequency ride through behaviour on inverter-based generating resources. It is anticipated that this standard will be applicable to the project currently under study. The Interconnection Customer is advised to consider the requirements of PRC-029-1 in their project design to ensure that their project can conform to these requirements. Conformance will be validated at the System Impact Study stage.

11 NSPI Interconnection Facilities and Network Upgrades Cost Estimate

Estimates for NSPI Interconnections Facilities and Network Upgrades for interconnecting 149.6 MW wind energy at the 230 kV POI on L-7027 are included in Table 8.

Table 8 Cost Estimate NRIS & ERIS @ POI L-7027		
Item	Network Upgrades	Estimate
1	Three breaker ring bus 230 kV substation complete with P&C at NSPI POI substation and connection to L-7027, including P&C modifications at 3C-Port Hastings and 67N-Onslow. The IC is also responsible for providing the substation site and access road.	\$9,000,000
2	Modifications to Limited Impact RAS (Group 3)	\$200,000
3	Modifications to Type 1 RAS (Group 5 & 6)	\$200,000
4	Modifications to L-7005/L-7027 current transformer relaying and metering settings.	-
	Sub-total for Network Upgrades	\$9,400,000
Item	TPIF Upgrades	Estimate
1	Build 0.075 km (estimated length) 230 kV spur line from TPIF to ICIF, with IC responsible to provide right-of-way	\$103,500
2	NSPI P&C relaying equipment	\$300,000
3	NSPI supplied RTU	\$100,000
4	Tele-protection and SCADA communications	\$750,000
	Sub-total for TPIF Upgrades	\$1,253,500
Total Upgrades		Estimate
	Network Upgrades + TPIF Upgrades	\$10,653,500
	Contingency (25%)	\$2,663,375
	Total (Incl. contingency and Excl. HST)	\$13,316,875

The preliminary non-binding cost estimate for interconnecting 149.6 MW at the POI at L-7027 under both NRIS and ERIS is \$13,316,875 including a contingency of 25%. In this estimate, \$9,400,000 (plus 25% contingency) of the amount represents Network Upgrade costs which are funded by the Interconnection Customer, but which are eligible for refund under the terms of the GIP. This does not include costs to address any potential stability issues identified at the SIS stage based on dynamic analysis, costs related to findings of the electromagnetic transient (EMT) analysis, and it assumes that RAS modification is approved by NPCC.

The estimated time to construct the Transmission Providers Interconnection Facilities and the Network Upgrades is 24-36 months after receipt of funds and cleared right of way from the IC.

12 Loss Factor

Loss factor is calculated by running the winter-peak load flow case (WIN_01) with and without the new facility in service, while keeping 91H-TuftsCove as the NS Area interchange bus. This methodology reflects the load center in and around 91H-Tufts Cove. A negative loss factor reflects a reduction in system losses.

The loss factor is calculated using the equation (01) and the data given in Table 9.

$$Loss\ Factor = \frac{(IR718_{POI} + TC_{withIR718}) - TC_{withoutIR718}}{IR718_{POI}} \quad (01)$$

Table 9 Data for Loss Factor Calculation	
Parameter/Measurement	Value (MW)
Power at POI of IR#718	145.9
Power generation at TC with IR#718	14.2
Power generation at TC without IR#718	148.4
Loss Factor	8.0 %

13 Preliminary Scope of Subsequent SIS

The following provides a preliminary scope of work for the subsequent SIS for IR#718.

The SIS will include a more comprehensive assessment of the technical issues and requirements to interconnect generation as requested. It will include contingency analysis, system stability, transient stability, ride through capability, and operation following a contingency (N-1 operation). The SIS must determine the facilities required to operate this facility at full capacity, withstand any contingencies (as defined by the criteria appropriate to the location) and identify any restrictions that must be placed on the system following a first contingency loss.

The SIS will confirm the options and ancillary equipment that the customer must install to control flicker, voltage response, frequency response, control interactions with other IBR facilities, active power and ensure that the facility has the required ride-through capability. The SIS will be conducted in accordance with the GIP with the assumption that all appropriate higher-queued projects proceed, and the facilities associated with those projects are installed. The following notice on OASIS provides additional clarification on the SIS model requirements:

NSPI-TPR-015-2: PSSE and PSCAD Model Requirements and NSPI-TPR-014-1: Model Quality Testing will undergo revision as the grid evolves and performance criteria changes. The most up to date version will be provided as they become available.

To be eligible for inclusion in the Interconnection System Impact Study stage, and thereby advance the Interconnection Request's initial Queue Position, the Interconnection Customer must meet the progression milestone requirements of Section 7.2 of the GIP at least ten (10) Business Days prior to the Interconnection System Impact Study commencement date. For clarity, item 7.2 (i) – provision of a detailed stability model for the generator(s) shall mean:

- *Provision of PSSE and PSCAD models in compliance with documents NSPI-TPR-015-2: PSSE and PSCAD Model Requirements, and*
- *Provision of test data demonstrating model testing in compliance with NERC, NPCC and NSPI criteria. NSPI-TPR-014-1: Model Quality Testing lists the minimum requirements that will be performed by NSPI. Additional testing may be performed to assess compliance with all applicable criteria. Any test not meeting the minimum NSPI requirements will be documented in the MQT report to the IC.*

The following outline provides the minimum scope that must be complete to assess the impacts. It is recognized the actual scope may deviate, to achieve the primary objectives. The assessment will consider but not be limited to the following:

- Facilities that the customer must install to meet the requirements of the GIP and the TSIR.
- The minimum transmission additions/upgrades that are necessary to permit operation of this Generating Facility, under all dispatch conditions, catering to the first contingencies listed.
- Guidelines and restrictions applicable to first contingency operation (curtailments etc.).
- Under-frequency load shedding impacts.

The SIS will assess system contingencies such that the system performance will meet the following criteria:

- Table 1 “Planning Design Criteria” of NPCC Directory 1.
- Table 1 “Steady State & Stability Performance Planning Events” of NERC TPL-001-5.1.
- NSPI System Design Criteria, report number NSPI-TPR-003-6.

Any changes to RAS schemes required for operation of this generating facility, in addition to existing generation and facilities that can proceed before this project, will be determined by the SIS as well as any required additional transmission facilities. The determination will be based on NPCC⁵ and NERC⁶ criteria as well as NSPI guidelines and good utility practice. The SIS will also determine the contingencies for which this facility must be curtailed.

⁵ NPCC criteria are set forth in its Reliability Reference Directory #1 Design and Operation of the Bulk Power System

⁶ NERC transmission criteria are set forth in NERC Reliability Standard TPL-001-5.1