



**NOVA SCOTIA POWER INC.
UTILITY SERVICE REQUIREMENTS**

2023 Edition

Effective May 1, 2023

**NOVA SCOTIA POWER INC.
UTILITY SERVICE REQUIREMENTS**

2023 UTILITY SERVICE REQUIREMENTS

Summary Of Changes



2023 Revision Effective: May 1st, 2023

Added, changed or deleted text is indicated by **bold italicized font**.

Clause	Revision	Action
1	<i>Commercial driveway:</i> <i>A commercial driveway is any temporary or permanent surface or accessway that is likely to be traveled by high sided vehicles. Examples of high sided vehicles include but are not limited to large delivery vans (cube vans), transport trucks, buses, waste collection vehicles, bucket trucks, construction machinery, cranes, and commercial snowplows.</i>	Addition
1	<i>Linked Homes:</i> <i>Single dwellings that are separated by a short distance and are linked physically in some way (e.g. breezeway, carport, shared foundation, etc.).</i>	Addition
10.1	The maximum single phase service entrance capacity shall be 600A unless permitted by the Utility in accordance with paragraph (4) below. Notwithstanding paragraph (4), the maximum single phase service entrance shall be sized as follows: <ul style="list-style-type: none"> a) 600 amps for a service switch rated at 80% b) 500 amps for a service switch rated at 100% capacity <ol style="list-style-type: none"> 1) <i>Single phase overhead service entrance capacity shall not exceed 400A unless approved by the supply authority.</i> Single phase overhead service entrances of 600A may be permitted <u>at the sole discretion of the Supply Authority.</u> 2) The maximum single phase, underground service entrance capacity when terminating at a <i>utility pole shall be 400A and may be increased to 600A at a service pole equipped with primary conductors.</i> Maximum of two runs per leg and a maximum individual conductor size of 500kcmil. 3) <i>The maximum single phase underground service,</i> terminating in a URD box <i>that is supplied from an overhead or padmount transformer</i> shall be 600A. These shall have a maximum of two runs per leg and a maximum individual conductor size of 500kcmil shall be allowed. 4) An 800 amp single phase underground service, <i>terminating at a padmount transformer,</i> may be permitted with Utility Approval. Installation shall be in accordance with Section 14: <i>Services Requiring Primary Equipment.</i> 	Change
12.7	<i>Services to Sheds, Recreational Vehicles, and Small Structures</i> Services for recreational vehicles shall be considered permanent regarding the requirements of the Canadian Electrical Code, Part 1. This type of service must be installed on a structure that is also intended to be permanent. The customer is responsible for the cost associated with the installation of <i>an acceptable pole</i> or other suitable structure that is acceptable to both the Supply Authority and the Inspection Department, and must be capable of supporting the service entrance equipment. Acceptable customer owned structures for an overhead supplied service include, but are not limited to, the options listed below. Other structures can be considered with the approval of both the Supply Authority and the Inspection Department. <ol style="list-style-type: none"> a) A small shed <i>or building that is suitably anchored to the earth in accordance with the National Building Code of Canada (2015), clause 9.23.6.1 and 9.23.6.3 as applicable.</i> b) A customer owned pole, as per Inspection Bulletin B-72-000 <i>that meets the requirements of SS-ED-22M, except that the pole shall be a minimum of class 5 strength (as indicated by a manufacturer's stamp).</i> The attachment point shall be able to withstand 750lbs of horizontal pull <i>and provide adequate ground clearance for the service, as determined by the supply authority.</i> If an NSPI owned pole is used to support the service entrance, then the meter and service box must be installed on a separate pedestal <i>that meets the requirements of 15.2 Clause 8.</i> The service entrance will then be run down the pole, and underground to the pedestal. See 12.10, Clause 1 below.	Change

12.8	5) The point of attachment shall be increased when crossing surfaces used by vehicular traffic such that it allows the utility to maintain a minimum design clearance of 4.5m over residential driveways and 5.5m over commercial driveways and any roadways. <i>The final span attaching directly to a residence or residential garage may have a reduced vertical clearance of 3.7m over residential driveways. This reduction accommodates the minimum service attachment height of 4.5m.</i>	Addition
13.1	Overhead primary with underground secondary service designs may be applied to individual residential units, semi-detached and row type housing units. The basic arrangement will be a pole mounted transformer plus secondary wires down the pole to an underground prefabricated junction box (URD box). The customer's individual underground services will be connected in this box. <i>The exception is 600A single phase services and larger, see section 10.1.</i> An individual customer who desires an underground service, and is not associated with other nearby customers who may be served overhead, does not require an underground secondary distribution system. The customer is responsible to extend their own service only and terminate it on a pole approved by the Utility as per Drawings 5U-ED-20M, 21M, and 10U-ED-22M (equivalent to 5U-ED-22M) <i>and Section 10.1.</i> This customer may be entitled to a rebate payment as per the rebate policy.	Change
14.2	9) The Customer shall provide NSPI with easements as described in Section 5.1. The Customer shall be responsible to provide and maintain clear access to the door/hood of the padmount cable entrance compartment. <i>This will be a space that is clear of bushes, trees, etc. that extends out from the padmounted equipment for 3m and allows the doors to be open at 90 degrees from the front face of the enclosure/transformer. In addition, a clear distance of not less than 1m from all sides of padmounted equipment that do not have access doors is required. Where a fire resisting barrier is used, the 1m of clearance is required from the outside of the barrier.</i>	Addition
14.5	It is recommended that transformers be located as far as practical from buildings, school yards and other occupied areas. Padmount Transformers shall be installed at least 3.0m horizontally away from <i>any utility pole, anchor,</i> overhead primary line, or any combustible surface or material on a building. They shall also be least 6.0m from any window, door, or ventilation inlets or outlet on a building, except where:	Addition
15.1	<i>4) Where 2 or more meter bases are present on a structure, the contractor shall install and label the meter base in a permanent and weatherproof manner to identify the unit or portion of premise the meter base serves. Permanent marker is not an acceptable means of identification.</i>	Addition
15.2	<i>8) A meter base may be located on a pedestal (stump post). These are to be constructed of 6in x 6in x 10ft pressure treated wood posts. Suitable alternatives to treated wood include galvanized or stainless steel capped pipe (minimum schedule 80) and struts with matching fasteners. The pedestal shall consist of one post for meter bases rated 200A or less and 2 posts for meter bases rated greater than 200A. Wood posts are to be set a minimum of 4ft deep. Steel posts must anchor to a suitable concrete base. Meter pedestals shall allow for the meter to be between 1.4m to 1.8m from ground. Pedestals are to be at least 3m from Utility poles and anchors. Mechanical protection around the meter pedestal is as required by the CEC.</i>	Addition
15.6	See updates to metering accessories table. Notes: <i>D. Switchgear rated above 1200A could require window style CTs instead of the 2-wire Bar CTs.</i>	Addition

NOVA SCOTIA POWER INC. UTILITY SERVICE REQUIREMENTS

Preface

The Utility Services Requirements book, as compiled by Nova Scotia Power Incorporated (NSPI), is intended to be a reference that will assist customers both new and existing, in obtaining a service connection, or a change to a service connection to the NSPI system. Included are copies of NSPI standards, as well as regulatory and other requirements that customers and/or their representatives must complete/comply with before a service connection can be made.

This document does not replace or supersede any requirements that are presented by the Inspection Authority before, during or after inspection.

This book is current at the time of publishing. If there is a discrepancy between any drawing or sketch as included in this book and the same drawing or sketch as published by NSPI in a Standards document, the published standard shall be assumed to be correct. NSPI Distribution Engineering staff shall make all interpretations of standards and requirements, and these shall be final. Such interpretations may vary among different installations as required by site specific conditions.

Any and all deviations from the requirements contained in this book must be approved by the Inspection Authority and/or NSPI Distribution Engineering staff.

The designs and clearances contained in the NSPI Standards Manuals for Overhead and Underground Systems have been developed for the practical construction and operation of the NSPI distribution system. In some instances, they may exceed the applicable standards of the Canadian Standards Association (CSA) as has been deemed appropriate by NSPI.

Where any third party, person or property is involved with incidents related to NSPI plant, it is the applicable CSA standard in effect at the time of construction that would normally apply. No responsibility is assumed or implied by NSPI for the applicability of any of the content of this book to systems that are owned by others, or in regard to their conformance with CSA or other National standards.

NSPI does not assume any responsibility for the application of these standards by anyone other than those employed by or acting on behalf of Nova Scotia Power Incorporated.

**NOVA SCOTIA POWER INC.
UTILITY SERVICE REQUIREMENTS**

Table of Contents

0	Scope.....	4
1	Definitions.....	4
2	Deviations from Requirements.....	6
3	The Canadian Electrical Code.....	6
4	Interference with Utility Equipment.....	6
5	Requirements for Service Connection.....	6
5.1	Easements and Right of Way Requirements.....	7
5.2	Changes in Service Requirements Before Connection.....	7
6	Supply Voltages.....	8
6.1	Secondary Supply Voltages.....	8
7	Large Electric Loads.....	8
8	Electric Motors.....	9
8.1	Motor Sizes.....	9
8.2	Motor Protection.....	9
9	Transfer Equipment for Standby Power Systems.....	9
10	Service Capacity.....	10
10.1	Single Phase.....	10
10.2	Three Phase.....	10
10.3	Largest Pole Mounted Transformer, Single Phase.....	11
11	Service to Residential Buildings (Single or Multiple Occupancy).....	11
12	Service Entrances.....	12
12.1	General.....	12
12.2	Service Entrance Disconnect.....	12
12.3	Temporary Service Entrances.....	12
12.4	Permanent Services.....	13
12.5	Prefabricated Homes.....	13
12.6	Mobile Homes.....	13
12.7	Services to Sheds, Recreational Vehicles, and Small Structures.....	14
12.8	Utility Supply Conductors Point of Attachment at Building or Structure.....	14
12.9	Customer’s Service Stacks and Conduits.....	16
12.10	Service Entrances on Utility Poles.....	16
13	Underground Residential Service.....	17
13.1	Policy.....	17
13.2	NSPI Payment Policy and Developer's Contribution.....	18
13.3	General Installation Details and Arrangements.....	18
13.4	Customer Responsibilities.....	19
13.5	NSPI Responsibilities.....	19

NOVA SCOTIA POWER INC. UTILITY SERVICE REQUIREMENTS

13.6	Secondary Service Box	20
13.7	Conduit Installation	20
13.8	Ground Tie	21
13.9	Sewer and Water	21
14	Services Requiring Primary Equipment.....	21
14.1	Policy	21
14.2	Customer Responsibilities.....	22
14.3	NSPI Responsibilities.....	23
14.4	Duct Banks	23
14.5	Transformer Installation.....	25
14.6	Customer Owned Secondary Cable	25
14.7	Ground Tie	26
14.8	Concrete Transformer Base	26
14.9	Alternative Transformer Base Construction.....	27
14.10	Fire-Resisting Barriers	27
14.11	Mechanical Protection	27
14.12	Definition of Backfill Materials	27
14.13	Primary Line Extensions	28
15	Metering.....	28
15.1	Electrical Contractor’s Responsibilities	28
15.2	Meter Locations.....	29
15.3	Instrument Transformers – 0 to 600 volts	30
15.4	Secondary Wiring	30
15.5	Service (System) Neutral	31
15.6	Three Phase Self-contained Metering Above 300V	31
15.7	Primary Metering.....	32
16	Service Request Process	33

Appendices

- APPENDIX A SERVICE ENTRANCE AND METERING CONFIGURATIONS
- APPENDIX B NSPI STANDARD DRAWINGS
- APPENDIX C NPSI APPROVED CONNECTORS LISTING
- APPENDIX D NPSI APPROVED UNDERGROUND MATERIALS

**NOVA SCOTIA POWER INC.
UTILITY SERVICE REQUIREMENTS**

NOVA SCOTIA POWER INC.

UTILITY SERVICE REQUIREMENTS

0 Scope

This document sets forth the minimum utility requirements for electrical service in the province of Nova Scotia, for all areas served by Nova Scotia Power Incorporated (NSPI). It is not to be regarded as a design specification and is not all inclusive with respect to the installation of electrical equipment or wiring.

These utility service requirements are in addition to the Canadian Electrical Code, Part 1 (CE Code), the NSPI Electrical Inspection Authority, and NSPI Utility Standards.

Construction shall not be undertaken based solely on this document, contact with both the Supply and Inspection Authorities is required for confirmation of site specific requirements and/or conditions.

1 Definitions

Complex Structure:

A complex structure is any structure that would be difficult to supply with a single utility service due to its physical characteristics or electrical requirements. The designation of a structure as 'complex' must be mutually agreed upon by both the Supply and Inspection Authorities.

Customer:

A Customer is defined as a person or company who is receiving, intends to receive, or has received electrical energy or electrical services from NSPI. Requests for service may be made by someone acting legally on behalf of the person or company.

Commercial driveway:

A commercial driveway is any temporary or permanent surface or accessway that is likely to be traveled by high sided vehicles. Examples of high sided vehicles include but are not limited to large delivery vans (cube vans), transport trucks, buses, waste collection vehicles, bucket trucks, construction machinery, cranes, and commercial snowplows.

Consumer's Service:

All the portion of the consumer's installation from the service box or its equivalent up to and including the point at which the supply authority makes connection.

Firewall/Fire Separation:

Where occupancies of a building are separated by a firewall or a fire separation, the occupancies may be considered as separate buildings for the purpose of electrical service. Firewalls and fire separations must be constructed in compliance with the National Building Code and confirmed as such in writing by a recognized building inspector, architect, or professional engineer.

Inspection Authority:

The Nova Scotia Department of Labour and Advanced Education have responsibility for enforcement of the Electrical Requirements in the Province of Nova Scotia. Nova Scotia Power's Electrical Inspection Department is authorized by their office to enforce the Canadian Electrical Code, Part 1 within NSPI's

NOVA SCOTIA POWER INC.

UTILITY SERVICE REQUIREMENTS

Service Area. The NSPI Electrical Inspection Department will also enforce the Utility Standards where applicable.

Inspection Department:

Within this document refers to the Nova Scotia Power Electrical Inspection Department.

Linked Homes:

Single dwellings that are separated by a short distance and are linked physically in some way (e.g. breezeway, carport, shared foundation, etc.).

Mobile Home:

A transportable, single or multiple section single family dwelling conforming to the CAN/CSA-Z240 MH Series at time of manufacture. It is ready for occupancy upon completion of set-up in accordance with required factory-recommended installation instructions.

Mobile Industrial or Commercial Structure:

Such structures are built specifically for commercial or industrial use, such as construction offices, bunk houses, wash houses, kitchen and dining units, libraries, TV units, industrial display units, laboratory units, and medical clinics.

Multiple Occupancy Buildings:

This includes strip malls or plazas, duplex, row and semi-detached housing, and other such structures.

Primary:

As used in this document in relation to voltages, primary means voltages in excess of 750 volts.

Safe Clearances Report:

A power services safe clearance report is a detailed report identifying any potential safety issues/hazards to the requested party who is required to complete work in close proximity of NSPI plant (lines or equipment). A copy of this report is provided to the requestor. Refer to the NSPI website to obtain one of these. <https://myaccount.nspower.ca/self-service/safe-clearance-cable-locate-request>

Service Box:

An approved assembly consisting of a metal box or cabinet constructed so that it may be locked or sealed, containing either service fuses and a service switch or a circuit breaker, and of such design that either the switch or circuit breaker may be manually operated when the box is closed.

Service Entrance:

The consumer owned conduit, conductors and/or cables, from the supply authority connection point to (but not including) the meter base.

Supply Authority (Interchangeable with Utility):

Nova Scotia Power, having the authority to supply electrical energy within its service area.

NOVA SCOTIA POWER INC.

UTILITY SERVICE REQUIREMENTS

Utility Approval:

Written or verbal approval from the Utility.

Utility Pole: All poles on which NSPI has distribution plant.

Utility Supply Conductors:

This term refers to the utility owned conductors connecting the Consumer's Service Conductors to the utility's system or transformer.

2 Deviations from Requirements

Utility and/or Inspection Department Approval is necessary for deviations from these requirements.

3 The Canadian Electrical Code

These Utility Service Requirements contain references to the Canadian Electrical Code, Part 1. This document does not however, constitute a complete explanation of all CE Code rules, which apply to service entrances.

Where the Canadian Electrical Code refers to compliance with the requirements of the local Supply Authority, then NSPI shall be consulted for approval.

4 Interference with Utility Equipment

The Supply Authority does not permit unauthorized disconnection or removal of meters, meter seals, utility supply conductors or any of its equipment. Requests for disconnection or removal of utility equipment shall be made to the NSPI's call center at (800)-428-6230.

Unauthorized removal of NSPI revenue meters may result in charges for retesting of the meter.

5 Requirements for Service Connection

Service entrances will be connected upon compliance with the following requirements:

- a) Supply Authority approval of the service entrance location, capacity and provisions for metering equipment.
- b) A valid wiring permit, for the installation, issued by NSPI.
- c) Authorization for a utility connection from the Inspection Department.
- d) Submittal of electrical plans shall comply with NSPI Electrical Inspection Bulletin B-2-014 "Submittal of Electrical Plans for Inspection Department Acceptance", and B-2-014.1 "Plans Review Submittal Form".
- e) Compliance of the installation with all other requirements of this document and the Canadian Electrical Code, Part 1.
- f) Establishment of all easement and right-of-way requirements as specified in [Section 5.1](#).
- g) A valid building permit when the municipal government with jurisdiction requires one for the facility being built by the customer.

NOVA SCOTIA POWER INC.

UTILITY SERVICE REQUIREMENTS

5.1 Easements and Right of Way Requirements

Where a service route as approved by the Supply Authority crosses private property the Customer shall be responsible for supplying and clearing the route.

The customer has overall responsibility for obtaining any easements or licenses. They are responsible for any costs incurred by NSPI in acquiring easements or licenses where regulations do not allow the customer to obtain them on behalf of NSPI.

The customer shall provide NSPI with easements for all NSPI assets such as ductbank, URD, transformer installation and pole lines under the following conditions:

- a) The installation crosses the customer's property.
- b) The installation crosses property not owned by the Customer.
- c) The installation supplies multiple Customers, regardless of whose property it is on.

Where an installation supplies one customer and crosses only that customer's property, an easement is not generally required unless specifically indicated by the utility.

Where an overhead installation is within 6m [20 feet] to a property line, at the edge of a road right of way, an easement may be required as indicated by Supply Authority.

Typical right-of-way width requirements are as follows:

- a) for primary overhead facilities is 12m [40 feet],
- b) for secondary overhead facilities is 5m [16 feet],
- c) for primary underground facilities is 6m [20 feet],
- d) for secondary underground facilities is 3m [10 feet].

The actual right-of-way dimensions and orientation details may vary by location. **The Supply Authority will provide and confirm the requirements on a case by case basis.**

5.2 Changes in Service Requirements Before Connection

Should the customer change the service voltage and/or the capacity requirements or any other electrical parameters of the new service after NSPI has installed or modified its' facilities to meet the original requirements, then the customer must pay all additional costs associated with reworking the newly installed or modified NSPI plant.

The customer is also responsible for all costs associated with physical changes that arise after utility facilities and equipment are planned, whether or not they have been installed, according to the original site layout.

NOVA SCOTIA POWER INC.

UTILITY SERVICE REQUIREMENTS

6 Supply Voltages

NSPI will normally supply one service with standard voltages and characteristics as specified in this section. When multiple supplies of different voltages or characteristics are requested for a single building (complex structure), approval must be obtained from the Supply Authority by the Customer or their Agent. Approval from the Inspection Authority for designation as this type of structure should also be obtained.

The Customer shall supply all transformation necessary to serve loads utilizing voltages different from that which is normally supplied by NSPI.

The frequency of all supply voltages is 60 hertz.

Refer to [Section 14](#) for requirements associated with service at primary voltages, which includes padmount transformer installations. Contact must be made with the Supply Authority for confirmation of the requirements for each particular installation.

6.1 Secondary Supply Voltages

The following are standard secondary and service voltages:

- a) 120/240 volt, single phase, three wire; or
- b) 120/208 volt, three phase, four wire grounded wye; or
- c) 347/600 volt, three phase, four wire grounded wye.

Where a high resistance grounded installation is requested, the configuration must be approved by the Supply Authority, and must conform to the Canadian Electrical Code.

Electric service may be provided to customers at other voltages with special permission from the supply authority. Existing non-standard installations shall be changed to conform with these requirements when alterations are made to the service. Consultation with the Engineering Department for the area in which the service resides is necessary.

7 Large Electric Loads

Operating large loads such as motors, electric furnaces, electric welders, air conditioners, heat pumps, etc., can produce momentary voltage sag or 'flicker': It is the responsibility of the Customer to ensure that electric loads which can produce momentary voltage sags or flicker are configured or controlled in such a way that sag or flicker is minimized.

The operating requirements of large loads should be given consideration during design of the service entrance. Consultation with the Supply Authority is required to ensure the adequacy of the Utility supply equipment. Failure to do so will result in charges to the customer for costs associated with any reworking of newly installed NSPI equipment that is required.

NOVA SCOTIA POWER INC. UTILITY SERVICE REQUIREMENTS

8 Electric Motors

8.1 Motor Sizes

- 1) The maximum motor sizes permitted for starting across the line shall be:
 - a) Single phase, 5.6 kW (7.5 horsepower)
 - b) Three phase 120/208 V, 11.2 kW (15 horsepower)
 - c) Three phase 347/600 V, 30 kW (40 horsepower)
- 2) Larger motors are permitted where:
 - a) The Customer installs reduced voltage or variable frequency start; or
 - b) Upon examination of the utility's system capabilities and the motor's characteristics, Utility Approval for starting across the line is granted.

8.2 Motor Protection

The Customer shall be responsible to provide all motor protection as per the CE Code.

NOTE: Normal overload protection will likely not provide adequate protection during loss of one supply phase. Loss of one phase of the utility supply (or of the building distribution system) may cause overheating and damage to three phase motors. Therefore, protection against the loss of one supply phase is recommended and shall be the responsibility of the customer.

9 Transfer Equipment for Standby Power Systems

Transfer switches for transferring the source of power from the utility system to a standby power system must meet the requirements of CE Code 14-612. The switch shall not allow the two sources to operate in parallel to prevent energizing or back feeding a de-energized utility distribution line on which crews may be working.

Where a design is such that a transfer switch will momentarily connect the Utility Supply and Generator Supply together in a synchronized manner using a closed transition transfer switch, the Utility shall be consulted prior to doing so and the installation shall meet the requirements as prescribed by the Utility prior to placing the transfer switch into service.

Other devices such as purpose built meter base accessories that accommodate the connection of standby generators are also acceptable and must have the approval of the Inspection Authority.

NOVA SCOTIA POWER INC.

UTILITY SERVICE REQUIREMENTS

10 Service Capacity

10.1 Single Phase

The maximum single phase service entrance capacity shall be 600A unless permitted by the Utility in accordance with paragraph (4) below. Notwithstanding paragraph (4), the maximum single phase service entrance shall be sized as follows:

- a) 600 amps for a service switch rated at 80% capacity
 - b) 500 amps for a service switch rated at 100% capacity
- 1) Single phase overhead service entrance capacity shall not exceed 400A unless approved by the supply authority. Single phase overhead service entrances of 600A may be permitted at the sole discretion of the Supply Authority.
 - 2) The maximum single phase, underground service entrance capacity when terminating at a utility pole shall be 400A and may be increased to 600A at a service pole equipped with primary conductors. Maximum of two runs per leg and a maximum individual conductor size of 500kcmil.
 - 3) The maximum single phase underground service, terminating in a URD box that is supplied from an overhead or padmount transformer shall be 600A. These shall have a maximum of two runs per leg and a maximum individual conductor size of 500kcmil shall be allowed.
 - 4) An 800A single phase underground service, terminating at a padmount transformer, may be permitted with Utility Approval. Installation shall be in accordance with Section 14: Services Requiring Primary Equipment.

10.2 Three Phase

- 1) The maximum overhead three phase, 120/208 volt service entrance capacity shall be 600 amps, provided the Customers service entrance switch is rated at 80% of nameplate capacity. If the Customers service entrance switch rated at 100% capacity, a padmounted transformer shall be considered, in accordance with [section 14](#) If Customer has a 100% rated switch, consult with Engineering.
- 2) The maximum permanent overhead three phase, 347/600 volt service entrance capacity shall be 200 amps, with either 80% or 100 % rated Customers service entrance switch.
- 3) The maximum three phase, 120/208 volt service entrance capacity run underground terminating at a utility pole shall be 600 amps. The maximum size Customer service conductor shall be 500kcmil, with a maximum of two runs per phase.
- 4) The maximum permanent three phase, 347/600 volt service entrance capacity run underground terminating at a utility pole shall be 400 amps, provided the Customers service entrance switch is fused at maximum of 250 amps. The maximum size Customer service conductor shall be 500kcmil, with a maximum of two runs per phase. If ampacity is rated higher see item 7).
- 5) The maximum temporary three phase, 347/600 volt service entrance capacity run overhead terminating at a utility pole shall be 400 amps, provided the Customers service entrance switch

NOVA SCOTIA POWER INC. UTILITY SERVICE REQUIREMENTS

is fused at maximum of 250 amps. The service conductor shall be no more than 100.0m total for all spans.

- 6) Notwithstanding paragraphs (1) and (2) above, larger overhead service ampacities may be permitted with Supply Authority approval. These are generally industrial or commercial buildings that are supplied from platform mounted utility transformers that are connected to the building by short conductors of large trade size. This type of installation is not preferred.
- 7) Services on which the required transformer capacity exceeds 225 kVA, three phase, regardless of service voltage, will normally be supplied from a padmount transformer. Installation details for padmounted transformers are in [Section 14](#). Other transformer arrangements/designs are possible, consult with the supply authority.

10.3 Largest Pole Mounted Transformer, Single Phase

The maximum size O/H single phase transformer to be installed for new services will be 75KVA.

If a transformer larger than 75kVA is required, consult with Engineering.

11 Service to Residential Buildings (Single or Multiple Occupancy)

- 1) Normally, one set of utility supply conductors is run to a residential multi-occupancy building.
- 2) Where more than one set of utility supply conductors is run to a residential multiple occupancy building:
 - a) The occupancies shall be completely self-contained (i.e. no indoor access between occupancies); and
 - b) The occupancies shall not be located one above the other; and
 - c) The occupancies shall have a separate entrance with direct access to ground level.
- 3) Fire pumps or other emergency systems may be supplied from a second utility supply. This does not always mean a second utility transformer will be provided. In the case of a padmounted transformer supplying the main service, this transformer should also supply fire pumps and other emergency systems through a second separate service fed from the same padmounted transformer.
- 4) Complex structures may have more than one utility supply. Both the Supply and Inspection Authorities must approve all installations where more than one supply service is requested or required.
- 5) See [Section 12](#) and Appendix A for service entrance guidelines.

NOVA SCOTIA POWER INC.

UTILITY SERVICE REQUIREMENTS

12 Service Entrances

12.1 General

Before commencing any service entrance installation (new, relocation, or upgrade of service) the Customer or their agent shall contact NSPI to obtain approval for the route of the utility supply conductors. The location of the service head and the location of the point of attachment for the utility supply conductors shall be in accordance with both the Canadian Electrical Code and NSPI standards.

The responsibility for obtaining easements (in a form specified by NSPI) and developing the right of way (ROW) are the responsibility of the customer as specified previously in [Section 5.1](#).

Any person working in or around energized equipment or power lines shall ensure they are doing so in compliance with the Occupational Health and Safety general regulations Part 11. No person shall work on or around NSPI power poles or lines without having a completed Safe Clearance Report.

12.2 Service Entrance Disconnect

- 1) As per CE Code Rule 6-206, sub-rule (1), paragraph (c) the main service disconnect shall be located as close as practicable to the point where the customer's service conductors enter the building. 'As close as practicable' shall not be more than 3 m in length and applies to the section of raceway which enters the building before it enters the main service switch.
- 2) When applied to a mobile home, in particular a skirted mobile home, as close as practicable shall not be more than 7.5 m.

Note– Clause 2 applies only to relocatable structures (factory-built) towable on their own chassis, for use without permanent foundations, and having provision for connection to utilities, including

- a) mobile homes; and
- b) mobile commercial and industrial structures.

When a mobile home is placed on a permanent foundation, as close as practicable shall be as per clause 1 above.

12.3 Temporary Service Entrances

- 1) A temporary service entrance is intended to be used for non-permanent, short-term applications and for construction power.
- 2) Overhead temporary services may be mounted on:
 - a) Construction shacks or trailers equipped with a service mast; or
 - b) A customer owned pole or tripod structure in accordance with NSPI Standard Drawings SS-ED-22M and SS-ED-23M, SS-ED-23MA, or
 - c) A utility secondary service pole, or
 - d) A utility pole that is supporting primary voltage and is dedicated to one customer

NOVA SCOTIA POWER INC. UTILITY SERVICE REQUIREMENTS

- 3) Where a temporary service is installed on a utility pole as permitted in clause 2 c) and d) above, it shall be installed with the weatherhead at a height that will place it in the secondary zone. For a pole with open secondary, the weatherhead will be above the two hot legs and below the neutral, for a pole with service cable only (triplex) the weatherhead must be within 150 mm of the triplex attachment point. If primary voltage conductors are on the pole, or if the installer is uncertain of the voltage, then the installer will contact the Supply Authority for a Safe Clearances Report before installing the service.
- 4) Temporary services connecting to an underground supply point shall be in accordance with drawing 8U-ED-40M.

12.4 Permanent Services

- 1) A permanent service shall be installed in accordance with NSPI Standard drawings J-ED-23M, J-ED-24M, SS-ED-10M, SS-ED-11M, SS-ED-12M, SS-ED-13M, and SS-ED-14M. Where a permanent service is installed on a Utility pole, it shall meet the minimum requirements of item 12.3 (c).

Note: Copies of drawings referenced above are included in Appendix B.

12.5 Prefabricated Homes

As with buildings constructed on site, the Customer shall obtain approval from the Supply Authority for the route of the utility supply conductors and the location of the service entrance for prefabricated homes (modular homes, mini homes, etc.) being constructed for a specific building lot.

12.6 Mobile Homes

See Definitions in Section 1.

- 1) As with buildings constructed on site, the Customer shall obtain approval from the Supply Authority for the route of the utility supply conductors and the location of the service entrance for mobile homes.
- 2) For the maximum length of service conduit permitted, see clause [12.2](#) (2) - Service Entrance Disconnect.
- 3) Service wires supplying one mobile home shall not pass over the roof of any other home.
- 4) Where the service wire crosses over a mobile home roof, the minimum clearance to the roof shall be 915mm in accordance with drawings SS-ED-24M and SS-ED-25M.
- 5) The maximum length of triplex service conductor to mobile homes is 23 meters unless the mobile home is model built to CAN/CSA-Z240MH Series 92 standard. These have been equipped with an improved mast support system. The maximum unsupported triplex utility service drop, to mobile homes, equipped with a factory installed service raceway support member, meeting or exceeding the above-noted standard and mounted on an acceptable block or concrete

NOVA SCOTIA POWER INC. UTILITY SERVICE REQUIREMENTS

foundation, may with utility approval, be increased to a maximum of 38 meters. The customer must provide proof that the mobile home being installed meets the above standard.

12.7 Services to Sheds, Recreational Vehicles, and Small Structures

Services for recreational vehicles shall be considered permanent regarding the requirements of the Canadian Electrical Code, Part 1. This type of service must be installed on a structure that is also intended to be permanent.

The customer is responsible for the cost associated with the installation of an acceptable pole or other suitable structure that is acceptable to both the Supply Authority and the Inspection Department, and must be capable of supporting the service entrance equipment.

Acceptable customer owned structures for an overhead supplied service include, but are not limited to, the options listed below. Other structures can be considered with the approval of both the Supply Authority and the Inspection Department.

- a) A small shed or building that is suitably anchored to the earth in accordance with the National Building Code of Canada (2015), clause 9.23.6.1 and 9.23.6.3 as applicable.
- b) A customer owned pole, as per Inspection Bulletin B-72-000 that meets the requirements of SS-ED-22M, except that the pole shall be a minimum of class 5 strength (as indicated by a manufacturer's stamp). The attachment point shall be able to withstand 750lbs of horizontal pull and provide adequate ground clearance for the service, as determined by the supply authority.

If an NSPI owned pole is used to support the service entrance, then the meter and service box must be installed on a separate pedestal that meets the requirements of 15.2 Clause 8. The service entrance will then be run down the pole, and underground to the pedestal. See 12.10, Clause 1.

12.8 Utility Supply Conductors Point of Attachment at Building or Structure

- 1) The point of attachment at buildings shall be in accordance with the CE Code and NSPI drawings SS-ED-10M, SS-ED-11M, SS-ED-12M, SS-ED-13M, SS-ED-14M, J-ED-23M, J-ED-24M as appropriate.
- 2) The point of attachment shall maintain a minimum conductor horizontal clearance of 1.0 meter from windows, doors, fire escapes and inaccessible portions of porches.
- 3) The point of attachment shall be such that it allows the utility to maintain a minimum design clearance of 1.0 m horizontal or 2.5m vertical between the utility supply conductors and building surfaces that are readily accessible but not normally used (e.g. a roof that is accessed for maintenance only).
- 4) The point of attachment shall be such that it allows the utility to maintain a minimum design clearance of 4.2m vertically if crossing over surfaces that are regularly used by persons such as decks, rooftop patios, yards, or any other area regularly accessed by persons.

NOVA SCOTIA POWER INC. UTILITY SERVICE REQUIREMENTS

- 5) The point of attachment shall be increased when crossing surfaces used by vehicular traffic such that it allows the utility to maintain a minimum design clearance of 4.5m over residential driveways and 5.5m over commercial driveways and any roadways. The final span attaching directly to a residence or residential garage may have a reduced vertical clearance of 3.7m over residential driveways. This reduction accommodates the minimum service attachment height of 4.5m.
- 6) Any customer owned service attachment structure (including poles), requires a suitable place to attach that can withstand 750lbs of horizontal pull.
- 7) The point of attachment for the NSPI supply conductors shall be on the same face of the building as the customer's service entrance or weather-head as required by CE Code Part 3, No.1, clause 5.7.2.2

"The point of attachment for supply conductors shall be on the same side of the building as the consumer's service head and shall be located such that

- a) the point of emergence of consumer's service conductors from the consumer's service head or the equivalent is a minimum of 150 mm and a maximum of 300 mm above the support for attachment of the overhead service conductors; and*
- b) A minimum of 150 mm and a maximum of 300 mm horizontally from the consumer's service head."*

For 'under eave' installations the horizontal distance may be increased to 500mm as shown on SS-ED-14M.

- 8) Services that are not accessible by bucket truck shall meet the requirements of clauses 10 and 11 to allow for safe ladder work. An attachment point is considered to be accessible by a bucket truck if the following conditions are met:
 - c) A public roadway or private driveway owned by the customer (or not owned by the customer with suitable easement/rights in place) with a reasonably level surface is available to park the bucket truck such that direct access to the service is possible from the bucket.
 - d) The roadway or driveway is usable 12 months of the year.
- 9) Service location on the building shall be in direct line of sight to the NSP utility pole as chosen by the supply authority.
- 10) The service attachment shall be on the side of a building and shall only be located on the side closest to the NSP service pole. In cases where the service cannot be accessed by an NSP bucket truck, the service will be accessed via ladder. Attachment points that are to be accessed via ladder shall be no further than 1.0m (3ft) back from the building face closest to the NSP service pole.
- 11) If the service attachment point is to be on the side of a building, line crews may require a ladder to reach the service location. A ladder ratio of 4:1 must be met by the site conditions. This ratio

NOVA SCOTIA POWER INC. UTILITY SERVICE REQUIREMENTS

shall be met when the ladder is against the building, without trespass on a neighbour's property. The roof mast is to be located within 45 cm from the edge of the roof within reach of the installers ladder. Stairs, plants, and trees shall not interfere with ladder use.

If the ladder access as noted above cannot be achieved, refer to SS-SK-07M or SS-SK-08M in Appendix A for the required service arrangement.

- 12) Where existing service entrances are upgraded or repairs are made to the service entrance above the meter base, or disconnect means for unmetered services, minimum height and clearance requirements as per the CE Code and NSPI Standards shall be met.
- 13) NSPI will supply the attachment device, the customer must install it.
- 14) If the point of attachment to a service mast exceeds 1.1m above the roof line, then the mast shall be guyed or braced.
- 15) Notwithstanding clause 9) above, a mid-span tap may be used, at the sole discretion of the supply authority, where no other practical location is available for attachment. If this is required, a site meeting with a Regional Planner can be arranged to discuss.

Note: At the discretion of the Supply Authority, or the Inspection Agency, and during an emergency repair only, a service may remain in the same location and/or at the same height above ground provided the original installation meets the minimum requirements of the CE Code Part 1 with respect to clearance of conductors. In all cases where a repair is made, the meterbase height and location shall be as per the Utility Standards unless previous authorization is granted prior to the repair.

12.9 Customer's Service Stacks and Conduits

- 1) The maximum number of service raceways shall not exceed four to any one building.
- 2) Multiple service weatherheads for a single customer on a building shall be located within 300mm of each other to allow for connection to a single set of utility supply conductors.

12.10 Service Entrances on Utility Poles

Service entrances (no meters) shall only be permitted on utility poles as follows:

- 1) Customer meters shall not be installed on any pole, notwithstanding items 5 and 6 below.
- 2) Service entrance may be installed on a service pole that carries only utility secondary conductors. Refer to NSPI Standard J-ED-34M.
- 3) In the case where a pole is supporting primary voltage and is dedicated to one customer, then service entrances may be installed on the pole. These shall be installed in accordance with drawing OU-ED-22M (meters are not permitted).

NOVA SCOTIA POWER INC. UTILITY SERVICE REQUIREMENTS

- 4) On a mainline primary pole, service raceway and length of conductor shall be installed in accordance with drawing OU-ED-22M.
- 5) CATV power supplies may be installed on utility poles, and shall be in accordance with drawing J-ED-15M. Other powered devices as required by communication companies that are resident on a pole, maybe installed when mutually agreed by the utility and the telecommunications company involved.
- 6) Installations by any parties other than the utility or communications companies that have an attachment agreement must be approved by NSPI Engineering.
- 7) The preferred service raceway on a pole is PVC conduit as per OU-ED-22M or J-ED-34M. If armoured cable is used on a pole than it must transition to a rigid conduit, a minimum of 1ft in length that is firmly attached to the pole using 2 clips with minimum 8in spacing. The conduit must terminate to a weatherhead (service entrance cap).
- 8) All service entrances constructed of conduit must have an expansion joint between 1 to 2 feet above finished grade.

NOTES:

- a. Prior approval of the supply authority is required for installations in accordance with paragraphs (2), (3) and (4) above. Approval shall include a completed Safe Clearances Report.
- b. Municipal Bylaws and requirements may impact on the ability of a customer to install a service entrance in accordance with paragraphs (2), (3) or (4) above.

13 Underground Residential Service

Before commencing any underground residential secondary service installation, the developer or their agent shall contact NSPI early in the planning stages of a development. At this time service location and design can be determined, arrangements made, and responsibilities discussed.

13.1 Policy

NSPI Regulation 2.11 states, in part:

"Distribution Systems - The Company may supply, install, maintain and own underground distribution systems. A party requesting the installation of an underground distribution system will be required to make a capital contribution to the Company, equivalent to the difference in cost between the underground system installed and overhead distribution facilities it would otherwise provide.

Secondary Services - The Company is not required to install underground secondary services: ... The customer will be responsible for ownership, maintenance and replacement when necessary. "

NOVA SCOTIA POWER INC. UTILITY SERVICE REQUIREMENTS

Overhead primary with underground secondary service designs may be applied to individual residential units, semi-detached and row type housing units. The basic arrangement will be a pole mounted transformer plus secondary wires down the pole to an underground prefabricated junction box (URD box). The customer's individual underground services will be connected in this box. The exception is 600A single phase services and larger, see section 10.1.

An individual customer who desires an underground service, and is not associated with other nearby customers who may be served overhead, does not require an underground secondary distribution system. The customer is responsible to extend their own service only and terminate it on a pole approved by the Utility as per Drawings 5U-ED-20M, 21M, and 10U-ED-22M (equivalent to 5U-ED-22M) and Section 10.1. This customer may be entitled to a rebate payment as per the rebate policy.

13.2 NSPI Payment Policy and Developer's Contribution

- 1) NSPI requires a customer contribution equal to the difference in cost between the cost of the underground secondary installation and the cost of overhead facilities normally provided by NSPI.
- 2) Costs will be calculated based on the design. The developer's contribution will cover costs associated with the underground installations with an allowance credited based on the number of services planned, present and future. Any change in the design will be negotiated as required.

13.3 General Installation Details and Arrangements

- 1) All Installation design and details are to comply with NSPI standard drawings.
- 2) The developer and NSPI will establish the exact location of the URD box in the field.
- 3) Final grade must be known and, if at all possible, rough final grade established prior to the installation of the URD box.
- 4) Driveway locations shall be established in order that proper clearances between boxes and driveways can be maintained and boxes will not end up under pavement.
- 5) Coordinating with NSPI and Communications utilities.
- 6) Access to a URD box is only permitted with NSPI approval. Work inside the URD box is permit when work is not impeded by abnormal factors (e.g. ice, mud, heavily damaged box...etc.). Approval will only be given to qualified electrician.
- 7) The use of transformer in conjunction with URD boxes shall comply with [Section 14](#) Services Requiring Primary Equipment for any primary side of the installation.

NOVA SCOTIA POWER INC. UTILITY SERVICE REQUIREMENTS

13.4 Customer Responsibilities

Customer is responsible for all the following at their cost:

- 1) Prepare a design indicating pole locations, the position of URD boxes, and the conduit system as per NSPI requirements.
- 2) The customer is responsible to consult with the various other utilities as to their requirements and excavate and prepare the required trenches for the utility's cables to their specifications.
- 3) The supply and installation of the entire conduit system from the poles or padmount transformers to the URD boxes.
- 4) Installation of the NSPI URD boxes and locators and supply and installation of the direct-burial warning tape.
- 5) The supply and installation of the ground tie adjacent to each conduit as per section 8U.
- 6) The developer is responsible for all excavation, sand bedding for the conduit and URD boxes, and backfilling of all trenching for the installation to NSP requirements.
- 7) The developer and/or customer are responsible for all aspects of the supply and installation of the individual services from the URD box to the residence. The connection of the services in the URD box shall be made by NSP.
- 8) Underground conduits installed by the developer and services must be inspected by NSPI and/or the area electrical inspection authority before backfilling.
- 9) The Customer shall provide NSPI with easements as described in [Section 5.1](#)
- 10) The homeowner shall own and maintain his own service from the URD box to the residence.

13.5 NSPI Responsibilities

- 1) NSPI will supply URD boxes to the contractor/developer for installation at their expense.
- 2) NSPI will supply, install, own and maintain the secondary conductors from the poles to the URD boxes, complete with connectors at the terminal poles and URD boxes and any required ground rods or grounding at terminal poles. NSP will make these connections to NSP requirements.
- 3) NSPI will supply and install the cable guard on the terminal pole.

NOVA SCOTIA POWER INC. UTILITY SERVICE REQUIREMENTS

13.6 Secondary Service Box

- 1) The URD boxes shall be located 1.5 m from the base of the service pole when serving dwellings on the same side of the street as the pole line (refer to drawing 7U-ED-21M). When on the opposite side of the street as the pole line, the URD box shall be located in line with the boundary line between the two dwellings to be served (refer to drawing 7U-E0-20M).
- 2) The developer is responsible for providing ducts to extend from the URD boxes onto each of the customer's properties. This will avoid the possibility of excavation being required under the sidewalk to connect or maintain a customer's service.
- 3) Below Grade URD boxes will be located 300 mm from the curb or the customer property line with a maximum of 150mm (6 inches) below final grade level. Sand may not be supplemented by the use of "crusher dust" around the URD boxes.
- 4) Above Grade URD boxes will be located as per 7U-ED-10M and 7U-ED-11M with the vehicular protection as required by the standard.
- 5) Customer secondary Cable shall extend 1.5m above the top cover of the URD box with the cable end positioned in the bottom center of the box.

13.7 Conduit Installation

- 1) All ducts and fittings must be CSA approved and installed to NSP Specification. Ducts shall be carefully installed and glued making certain that all joints are tight. Any ingress of materials into the ducts is not acceptable.
- 2) Underground conduit shall be in a trench constructed in accordance with drawing 1U-ED-12M for non-traffic areas and drawing 1U-ED-44M for crossing areas with vehicular traffic (crossing driveways, roadways, etc.). All ducts that cross roadways are to be concrete encased including a capped spare for future use.
- 3) Ducts shall face away from the flow of traffic and shall not be installed on the curb or sidewalk side of the terminal pole – Refer to Drawing 1U-ED-25M for duct termination at pole
- 4) Refer to drawings 2U-ED-30M and 50M for details on the URD box installation and ducting from a padmount transformer or Pole.
- 5) All ducts are to be kept clear, swabbed, and provided with a fish line item N1000. Ducts are to be capped at both ends.
- 6) The 90 degree bends at the terminal pole shall be rigid PVC and rigid PVC must extend up the pole. Rigid PVC type to be used for the remainder of the duct run.
- 7) Clearances are to be strictly maintained as shown in Drawings 1U-ED-32M, 41 M, 42M, 44M, and 45M.

NOVA SCOTIA POWER INC. UTILITY SERVICE REQUIREMENTS

- 8) Backfilling - When utilities are complete in the trench and have been inspected, the developer will backfill using material free of large rocks and acceptable to NSPI for this purpose.

13.8 Ground Tie

- 1) Ground Tie - This shall be a minimum #2 AWG bare copper conductor installed from the terminal pole adjacent to the direct buried conduit for a minimum length of 15m. All ground connections will be made by NSPI.
- 2) Conduits extending less than 5m from the pole do not require a ground tie.

13.9 Sewer and Water

- 1) Cable should not be installed in the same excavation as sewer and water facilities, except under specific circumstances. Right angle crossings are often unavoidable.
- 2) Sufficient clearance is required between sewer and water pipes and cables to allow for the excavation of the sewer and water facilities without interfering with the cable installation. Refer to drawings 1U-ED-32M and 1U-ED-42M.
- 3) Where at all possible, sewer and water facilities must be in place and backfilled before the installation of conduits and cables.

14 Services Requiring Primary Equipment

Some larger facilities will require the installation of a transformer that is too large for mounting on a single pole and/or a primary line extension. The customer will be referred to the local Engineering or Planning Office for particulars and approval.

Where a vault is required for service, the developer shall engage the Supply Authority to provide vault requirements according to Regional Engineering's direction.

All NSPI Standard Drawings referred to in this section are included in Appendix B.

14.1 Policy

NSPI Regulation 2.1 regarding transformer installation states the following:

"When in the Company's opinion, it is impractical to provide the customer's electrical requirements from existing Company facilities the customer must, on the request of the Company, provide suitable transformer(s) space on the customer's premises for the necessary transformers. The type and location of primary service equipment must be approved by the Company for each installation".

The space for the primary service equipment may be in the form of a suitable room inside the building or a designated space on the property outside the building.

NOVA SCOTIA POWER INC. UTILITY SERVICE REQUIREMENTS

14.2 Customer Responsibilities

- 1) The customer shall provide NSPI with site drawings and an estimate of connected electrical load at the earliest possible stage of planning. This will permit the Utility to determine an acceptable method of service and point of supply. It will also provide lead time for the ordering of electrical equipment.
- 2) The customer shall provide, as soon as possible, electrical plans for the buildings and other facilities/structures which are to be submitted to the Inspection Authority and accepted before service arrangements can be finalized. When field scoping/design is complete and the service arrangements are finalized, materials such as transformers may be ordered subject to the requirements of 14.2.5.
- 3) The following requirements must be met before temporary or permanent service connection can be provided:
 - a) A building permit must have been obtained from the applicable municipal authority.
 - b) Authorization must be given by the electrical inspection authority.
 - c) An electric service contract must be completed by the party accepting responsibility for the electric service account. A security deposit may be required as part of the service contract.
- 4) The customer shall be responsible for the additional expense of any temporary service required for construction power. Arrangements must be made with NSPI for the connection of a temporary service.
- 5) The customer will be required to make a capital contribution if the service requirements exceed the Utility's normal service allowance. The allowance consists of 92 metres of overhead line extension or 46 meters of high voltage underground cable. Payment of the contribution will be required before electric service can be provided.
- 6) The customer shall provide, own and maintain all secondary voltage electrical equipment. This includes the electrical cables from the customer's main disconnect switch to the padmounted transformer and the connectors required for the secondary terminations on the transformer (see Appendix C). The secondary cables shall be installed by the electrical contractor such that the end of each secondary cable extends a minimum of 2 metres above the transformer base. This is required to ensure sufficient cable for connection to the transformer. The connection of secondary cables to the transformer will be done by NSPI.
- 7) All customer-owned electrical equipment must be inspected and approved by the appropriate inspection authority.
- 8) The customer shall provide, own and maintain the civil structures necessary to support the high voltage electrical equipment. The civil structures generally consist of a concrete base for the padmounted transformer and a concrete encased ductbank for the high voltage cable. The ductbank and the transformer base must be inspected and approved by NSPI. See drawings 6U-ED-10M, 11M, 20M, 21M, 24M, and 25M for details.

NOVA SCOTIA POWER INC. UTILITY SERVICE REQUIREMENTS

- 9) The Customer shall provide NSPI with easements as described in [Section 5.1](#). The Customer shall be responsible to provide and maintain clear access to the door/hood of the padmount cable entrance compartment. This will be a space that is clear of bushes, trees, etc. that extends out from the padmounted equipment for 3m and allows the doors to be open at 90 degrees from the front face of the enclosure/transformer. In addition, a clear distance of not less than 1m from all sides of padmounted equipment that do not have access doors is required. Where a fire resisting barrier is used, the 1m of clearance is required from the outside of the barrier.

14.3 NSPI Responsibilities

- 1) NSPI will normally supply, own and maintain the high voltage cable, complete with terminations, and the padmounted transformer.
- 2) In certain cases, the customer may arrange or be required to supply the high voltage cable and the transformer. These situations will be rare and will be dealt with on an individual basis.
- 3) Connection of all cables to the transformer unit will be performed by NSPI.

14.4 Duct Banks

The customer shall provide a suitable underground ductbank as shown on Dwg. 1U-ED-12M and Dwg. 1U-ED-14M. If telephone ducts are not required, they may be eliminated along with the wooden plank separation. Drawing 5U-ED-10M shows details of the non-joint use duct bank. Appendix 5 contains an approved hardware and materials list to be used in conjunction with the drawings in this document. Item numbers shown in circles or ovals on the drawings are cross-referenced in this listing to the appropriate description and part numbers.

The following specifications must be met:

- 1) All ducts and fittings must be approved by a recognized Certification Agency. (e.g., CSA or CUL)
- 2) All Primary Ducts are to be concrete encased unless otherwise specified by NSPI. Secondary ducts may be direct buried unless otherwise specified by NSPI. All ducts that cross roadways are to be concrete encased.
- 3) Ducts must be supported by approved spacers. Wire or metal ties are not to be used to support the electrical ducts.
- 4) Duct risers at poles shall face away from the flow of vehicular traffic and shall not be installed on the curb or sidewalk side of the terminal pole.
- 5) Ducts shall be carefully installed, and all joints are to be glued unless the duct system is specifically designed for friction or snap fit. Such duct systems must be preapproved by NSPI Engineering. Foreign material is to be kept out of the ducts.

NOVA SCOTIA POWER INC. UTILITY SERVICE REQUIREMENTS

- 6) Long sweep 90 degree rigid PVC or heavy wall FRE bends shall be used at both the pole and the concrete pad. PVC type, DBII or FRE may be used for the remainder of the duct run.
- 7) The standard duct size shall be 100 mm. When the equivalent of more than 3 90 degree bends are required between pulling points, or the duct run is in excess of 90 metres in length, 125 mm duct shall be used.
- 8) The primary ductbank and concrete pad are to be formed and inspected by the Utility before pouring any concrete. In joint use applications representatives from both NSPI and Bell must be called for inspection purposes. A 75 mm envelope of concrete is required around the ductbank.
- 9) All ducts are to be swabbed and a 4 mm polyethylene fish line installed in each duct. Ducts are to be sealed with proper caps at both ends.
- 10) A 1.5 m separation shall be maintained between the ductbank and a fuel storage system or a steam line. See Drawing NO. 1U-ED-41M for details on the required separation between ductbanks and various underground structures.
- 11) A 1.5 m minimum horizontal separation shall be maintained between a high voltage ductbank and a swimming pool.
- 12) A ductbank shall not run directly above or below other underground systems such as water, sewer, or communications. An electrical ductbank may cross other underground systems at right angles as long as a minimum separation of 600 mm is maintained.
- 13) Under some conditions, it will be necessary to place some reinforcing steel in the ductbank. Typical examples include fluid or unstable soil conditions or where a ductbank passes under a retaining wall or building foundation. Details of the proposed installation must be approved by NSPI.
- 14) At the riser pole, there is to be a 12 mm spacer between each duct and the pole.
- 15) Marker tape approved by NSPI shall be installed above all primary ductbanks. The marker tape shall be located 300 mm below finished grade. Installation of this tape must be verified by NSPI before it is covered.
- 16) The ductbank shall be placed under the cable compartment portion of the concrete base (the portion adjacent to the rectangular hole). It shall not be placed under the transformer part (the remaining portion) of the concrete base. Refer to Figure 14.6.1 in the following section.

NOVA SCOTIA POWER INC. UTILITY SERVICE REQUIREMENTS

14.5 Transformer Installation

It is recommended that transformers be located as far as practical from buildings, school yards and other occupied areas. Padmount Transformers shall be installed at least 3.0m horizontally away from any utility pole, anchor, overhead primary line, or any combustible surface or material on a building. They shall also be least 6.0m from any window, door, or ventilation inlets or outlet on a building, except where:

- 1) A Fire-Resisting Barrier is installed and has been approved by NSPI as per [Section 14.10](#) Fire-Resisting Barrier
- 2) The transformer is protected by an internal current-limiting fuse and equipped with a pressure relief device with working space around the transformer of at least 3m on the access side and 1m on all other sides.

A fire-resisting barrier or vehicular protection may be required in certain circumstances. [Section 14.10](#) outlines the requirements for fire-resisting barriers. [Section 14.11](#) outlines the requirements for vehicular protection.

14.6 Customer Owned Secondary Cable

- 1) Secondary cables, whether directly buried or in duct, shall not be placed under the transformer section of the concrete transformer base (see Figure 14.6.1 for area definitions). The secondary cables are to be placed under the cable compartment section of the transformer base.

Figure 14.6.1: Transformer Pad Allocations

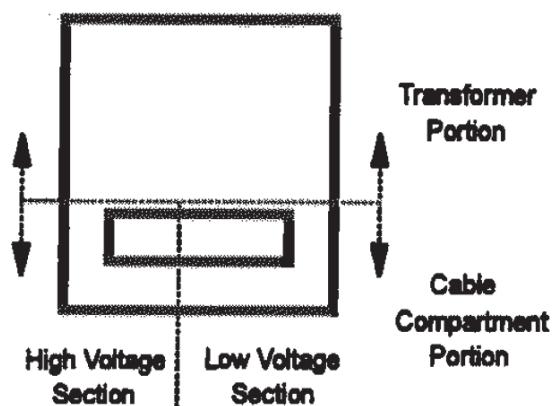

- 2) Secondary cables are not to be installed in the high voltage section of the transformer.
- 3) Secondary cables are to be connected to the transformer using approved compression lugs (see Appendix C). The compression lugs are to be supplied by the customer and installed by NSPI. NSPI will supply the stainless steel connection hardware.

NOVA SCOTIA POWER INC. UTILITY SERVICE REQUIREMENTS

- 4) Permanent secondary cables are not to be energized or used for temporary service without permission from NSPI.
- 5) The maximum number of cables per phase that may be terminated at a transformer shall be as shown in table 4U-7M (Appendix B).

14.7 Ground Tie

The customer shall provide a ground tie between the padmounted transformer and the riser pole (see Drawing No. 1U-ED-12M and 1U-ED-14M). The ground tie shall be a bare copper conductor installed beneath the concrete ductbank. It may also be installed immediately adjacent to the ductbank (on either side). When installed under the ductbank, it shall be inspected by NSPI prior to pouring the concrete for the ductbank. When installed beside the ductbank it shall be verified by NSPI prior to backfilling the trench. NSPI will connect the ground tie to the riser pole ground rod.

14.8 Concrete Transformer Base

Where a padmounted transformer is required, the Customer shall contact the Utility, and will be referred to the Engineering Department for design and approval requirements regarding transformer pad location and construction standards, trenching and duct installation details, grounding, concrete specifications, cable installation guidelines, etc.

The customer shall provide a suitable poured in place concrete base for the padmounted transformer. The base shall be constructed to NSPI specifications using the drawings found in this document. NSPI will select the appropriate transformer size based on estimated load information provided by the customer and other pertinent factors.

- 1) The transformer base shall be inspected by NSPI during construction and approval given before any backfilling or pouring of concrete.
- 2) The concrete base shall be located in an area that is permanently accessible by NSPI maintenance vehicles. It shall be located within 3.0m of a roadway, parking lot, or other reasonable means of access.
- 3) The area surrounding the transformer shall be kept clear of any obstructions (bushes, trees, posts, etc.) for a distance of one meter out from all sides of the concrete base.
- 4) Grounding around the concrete base shall be provided by the customer in accordance with Drawings 10U-ED-11M and 30M. Ground rods are not to be installed under the concrete base. The grounding installation must be inspected by NSPI before it is covered over.
- 5) The use of pre-cast transformer bases is acceptable if they have been constructed in accordance with NSPI specification and have been approved by NSPI.

NOVA SCOTIA POWER INC. UTILITY SERVICE REQUIREMENTS

- 6) No padmounted transformer shall be installed on a pad until the concrete has been allowed to set for a minimum of forty-eight hours.
- 7) When the secondary cables are 750kcmil or larger, the deep-well transformer pad is required. Refer to 6U-ED-26M.

14.9 Alternative Transformer Base Construction

Notwithstanding [section 14.8](#), the customer may provide a suitable base for the padmounted transformer that is manufactured from: (1) fiberglass, (2) plastic or other composite material, or (3) precast concrete.

Approval of NSPI Distribution Standards Department is required before purchase or installation.

14.10 Fire-Resisting Barriers

Fire-resisting barriers must be constructed between the transformer and the door, window, ventilation opening or combustible surface when required by [Section 14.5](#).

For details on the construction of these barriers, see 6U-ED-12M, 13M, 22M, 23M, 28M, 29M, and 38M.

In case of dispute, the local Inspection Authority in conjunction with the Supply Authority shall determine the barrier requirements.

14.11 Mechanical Protection

Mechanical protection is required to protect the transformer from being accidentally hit by vehicles. This is most commonly applied for transformers close to driveways, parking lots, or loading bay areas. If it is judged by NSPI that the transformer would be in danger of being hit by traffic, protection will be required on one or more sides. This shall be constructed as shown on Drawing No. 6U-ED-40M for three phase transformers and 7U-ED-10M and 11M for single phase transformers.

14.12 Definition of Backfill Materials

The transformer base (or pad) drawings refer to several types of backfill materials.

- 1) Gravel backfill – shall consist of well graded, clean granular material containing no material larger than 50 mm in size and shall meet the requirements of gravel – Class C as specified by the Department of Transportation.
- 2) Crushed rock backfill – shall consist of 20 mm clear crushed rock. Crushed rock backfill shall be used as a base for certain construction, as specified.

NOVA SCOTIA POWER INC. UTILITY SERVICE REQUIREMENTS

- 3) Crushed stone topping – shall consist of angular shaped, hard, igneous rock, crushed, screened and washed. Soft rock, shale, or slate is not acceptable. The product shall be of uniform quality throughout and shall be free of flat, elongated, round or other objectionable pieces. No earth, sod, silt, clay or any foreign or vegetative matter shall be allowed in this material. The purpose of the crushed stone topping is to reduce electric shock hazard and provide a stable working surface around the padmounted transformer.

14.13 Primary Line Extensions

Individual customers are entitled to an overhead line extension credit, up to a maximum of 92m. NSPI will determine the point of attachment at both the customers' point of connection and NSPI plant. Any length over this amount will require a capital contribution from the customer.

Customers must contact NSPI to determine the suitability of any lines near the site of the new service. Not all lines are suitable for direct attachment of customers. NSPI must determine which line(s) are suitable for the installation being considered. Site planning by the customer should not assume the point of connection or routing for primary lines as this is the responsibility of NSPI.

Refer to NSPI regulation 2.6 on line extensions.

15 Metering

General

All meter installations shall comply with NSPI Metering Standards. Existing non-standard installations shall be changed to conform with these standards when alterations are made to the service.

All new and upgraded three phase 4 wire meter installations, self-contained or transformer rated shall require 3 element meters to be installed. Three phase 2 ½ element meters are only used for replacement of existing 2 ½ element meters.

Specialized metering installations not covered by these standards shall be developed by Regional Engineering and approved by Meter Services.

15.1 Electrical Contractor's Responsibilities

- 1) The electrical contractor shall supply and install all meter sockets, cabinets, conduit (for CT & PT secondary leads as required) and current transformers lugs.
- 2) The contractor is responsible for the installation of transformers in metal enclosures as per the requirements of Canadian Electrical Code for enclosures for instrument transformers (Rule 6-404). Enclosures shall have provision for sealing.
- 3) The contractor is responsible for connections to the primary side of current transformers.

NOVA SCOTIA POWER INC. UTILITY SERVICE REQUIREMENTS

- 4) Where 2 or more meter bases are present on a structure, the contractor shall install and label the meter base in a permanent and weatherproof manner to identify the unit or portion of premise the meter base serves. Permanent marker is not an acceptable means of identification.

NOTES:

- a) NSPI will supply all revenue class potential and current transformers.
- b) NSPI will supply and install colour-coded secondary wiring from current transformers to meter socket and wiring to the primary and secondary side of potential transformers.

15.2 Meter Locations

- 1) The Meter and associated metering equipment shall be in locations satisfactory to both inspection and supply authority (refer to Canadian Electrical Code Part I, Rules 6-402 and 6-408, and metering standards MS 7.0). The center of the meter shall not be higher than 1.8 m or lower than 1.4 m from the floor or ground level. Meters and metering equipment may be placed outdoors if they are of weatherproof construction or in weatherproof enclosures.
- 2) Normally meter sockets are to be located on the outside of the building. Utility approval is required for meter sockets to be located inside of buildings with the exception of multiple occupancy buildings with more than four meter positions.
- 3) Meters shall not be located in bins, closets, bathrooms, stairways, high ambient temperature room, dangerous or hazardous locations, or in any similar undesirable places.
- 4) For multiple meter installations, as in apartment buildings, office buildings, industrial complexes, etc., the meters shall be conveniently grouped and readily accessible to Meter Readers and Installers during normal business hours.
- 5) A clear working space of 1.0 m minimum must be provided in front of all meter panels, free of any temporary or permanent obstruction. Passageways and working space around electrical equipment shall not be used for storage and must be kept free from obstruction. (Canadian Electrical Code, Part I, Rules 2-300 through 2-322 deal with these and related items).
- 6) Meters shall be installed a minimum of 1.0m from any natural gas discharge opening and 3.0 meters from any propane gas discharge opening.
- 7) Every meter shall be installed in a level position and solidly fixed to a wall or other support supplied by the customer, free from excessive vibration. If the meter location proves to be susceptible to vandalism or frequent breakage by other means, a protective enclosure shall be installed at the customer's expense.
- 8) A meter base may be located on a pedestal (stump post). These are to be constructed of 6in x 6in x 10ft pressure treated wood posts. Suitable alternatives to treated wood include galvanized or stainless steel capped pipe (minimum schedule 80) and struts with matching fasteners. The pedestal shall consist of one post for meter bases rated 200A or less and 2 posts for meter bases

NOVA SCOTIA POWER INC. UTILITY SERVICE REQUIREMENTS

rated greater than 200A. Wood posts are to be set a minimum of 4ft deep. Steel posts must anchor to a suitable concrete base. Meter pedestals shall allow for the meter to be between 1.4m to 1.8m from ground. Pedestals are to be at least 3m from Utility poles and anchors. Mechanical protection around the meter pedestal is as required by the CE Code.

- 9) When a customer requires a recessed wall installation, adequate room must be provided to install/remove meters and faceplate of the meter base.
- 10) For temporary service enclosures the meter base shall be installed on the outside of the weatherproof box. (Ref. Electrical Inspection Bulletin B-76-008)
- 11) A request shall be made to the Supply Authority via the deviation process where there is a requirement to install more than four (4) consumer services to any one building. The request will also be made to the Inspection authority via the process outlined in Rule 2-030 of the CE Code. The Supply Authority will not connect the service without approval from the Inspection Authority.
- 12) Where an addition is built on an existing premise, or renovations to a premise are such that the meter base will be located in an undesirable location in accordance with the Supply Authority, the meter socket shall be relocated to a suitable location.

15.3 Instrument Transformers – 0 to 600 volts

- 1) NSPI will supply the necessary Instrument Transformers; however, the contractor must arrange to have them installed at his expense at the factory or in the field. Refer to Metering Standard MS 4.0 for standard layouts.
- 2) In the case of factory-built custom switchgear, space is to be provided for instrument transformers and test blocks which are readily accessible for inspection; the compartment or enclosure for instrument transformers must have provision for sealing.
- 3) The instrument transformers are to be electrically connected on the load side of the service box immediately after customer main service switch (C.E. Code Part I, Rule 6-402[2]).

15.4 Secondary Wiring

- 1) Electrical raceway shall be supplied and installed by the contractor from instrument transformer cabinets or primary metering equipment to meters in minimum sizes noted below:
 - c. Single phase service 2 & 3-wire meter, 20 mm (3/4").
 - d. Three phase four-wire service, 25 mm (1").
- 2) The raceway run shall be as short as practical; however, no run may exceed 30 m or contain the equivalent of more than three 90-degree bends.
- 3) All meters, meter sockets, metal raceways, cabinets, etc. shall be bonded to ground in accordance with Canadian Electrical Code Part I, Section 10.

NOVA SCOTIA POWER INC. UTILITY SERVICE REQUIREMENTS

15.5 Service (System) Neutral

- 1) The service (system) neutral conductor is to be connected to all single phase meter sockets up to and including 200A. For single phase transformer rated installations the instrument transformer cabinet must be bonded either through metallic conduit or suitably rated conductor (Canadian Electrical Code, Table 16A or Table 16B). The neutral shall pass through the cabinet unbroken.
- 2) Every three phase, four-wire system being metered with instrument transformers shall have the service neutral available at the main switch. The neutral must be accessible (at a lug) for line to neutral metering.
- 3) In some installations, the customer does not require phase-to-neutral voltage; however, NSPI is required by Measurement Canada to use phase-to-neutral connections on low potential installations.
- 4) For further details on system neutral sizing requirements refer to Canadian Electrical Code Rule 4-024.

15.6 Three Phase Self-contained Metering Above 300V

- 1) All three phase self-contained metering installations on services or sub-services above 300 Volts shall have a disconnect on the line side of the meter. This disconnect shall be immediately adjacent to, or integrated with, the meter base.
- 2) An insulated neutral conductor is required when the meter base is located on the load side of the disconnecting means.
- 3) Meter bases used in conjunction with instrument transformer type meters shall be combination type to accept the test switch.

**NOVA SCOTIA POWER INC.
UTILITY SERVICE REQUIREMENTS**

METERING ACCESSORIES				
SERVICES	CT CABINET	SOCKETS REQUIRED	INSTRUMENT TRANSFORMERS REQUIRED	SEE NOTES
1PH, 3-WIRE, 200A MAX	N/A	4 JAW	NONE	B
1 PH, 3-WIRE, ABOVE 200A TRANSFORMER RATED	YES	5 JAW COMBINATION	ONE 3-WIRE CT (TWO 2-WIRE CTS ABOVE 600A)	C
1 PH, 3-WIRE, ABOVE 200A SELF CONTAINED	NO	TYPE CL320 C/W BYPASS	NONE	B
NETWORK, 120/208V, 200A MAX	N/A	5 JAW, 9 O'CLOCK POSITION	NONE	B
3 PH, 4-WIRE, 120/208V, 200A MAX	N/A	7 JAW	NONE	B
3 PH, 4-WIRE, 120/208V, ABOVE 200A	YES	13 JAW COMBINATION	THREE 2 WIRE BAR CTS	C, D
3 PH, 4-WIRE, 347/600V, 200A MAX	N/A	7 JAW	NONE	A, B
3 PH, 4-WIRE, 347/600V, ABOVE 200A	YES	13 JAW COMBINATION	THREE 2-WIRE BAR CT'S AND THREE PT'S	C, D

NOTES:

- A. All three phase self-contained services or sub-services above 300V shall have a disconnect on the line side of the meter and shall be immediately adjacent to or integrated with the meter base.
- B. Isolated neutral required when meter base is located on load side of disconnecting means.
- C. Meter bases to be used in conjunction with instrument transformer type meters shall be combination type to accept the test switch.
- D. Switchgear rated above 1200A could require window style CTs instead of the 2-wire Bar CTs.

15.7 Primary Metering

NSPI Regulation 4.4 states the following: "Metering will normally be at the secondary side of the transformer. Should the customer's requirements make it necessary for the Company to provide primary metering, then the customer will be required to make a capital contribution equal to the additional cost of the primary metering."

The additional costs referred to in the regulation as quoted above include full equipment purchase and installation costs (unless otherwise noted) for the following:

- 1) primary metering equipment,
- 2) installation of any poles, platforms, foundations, or other supporting structures as required for the equipment,
- 3) changes and modifications to existing NSPI facilities as required to accommodate the primary metering,
- 4) removal of any facilities as required to accommodate the primary metering,
- 5) any other modifications or additions as required to accommodate the installation

NOVA SCOTIA POWER INC. UTILITY SERVICE REQUIREMENTS

16 Service Request Process

NSPI UTILITY SERVICE REQUEST PROCESS FLOW CHART

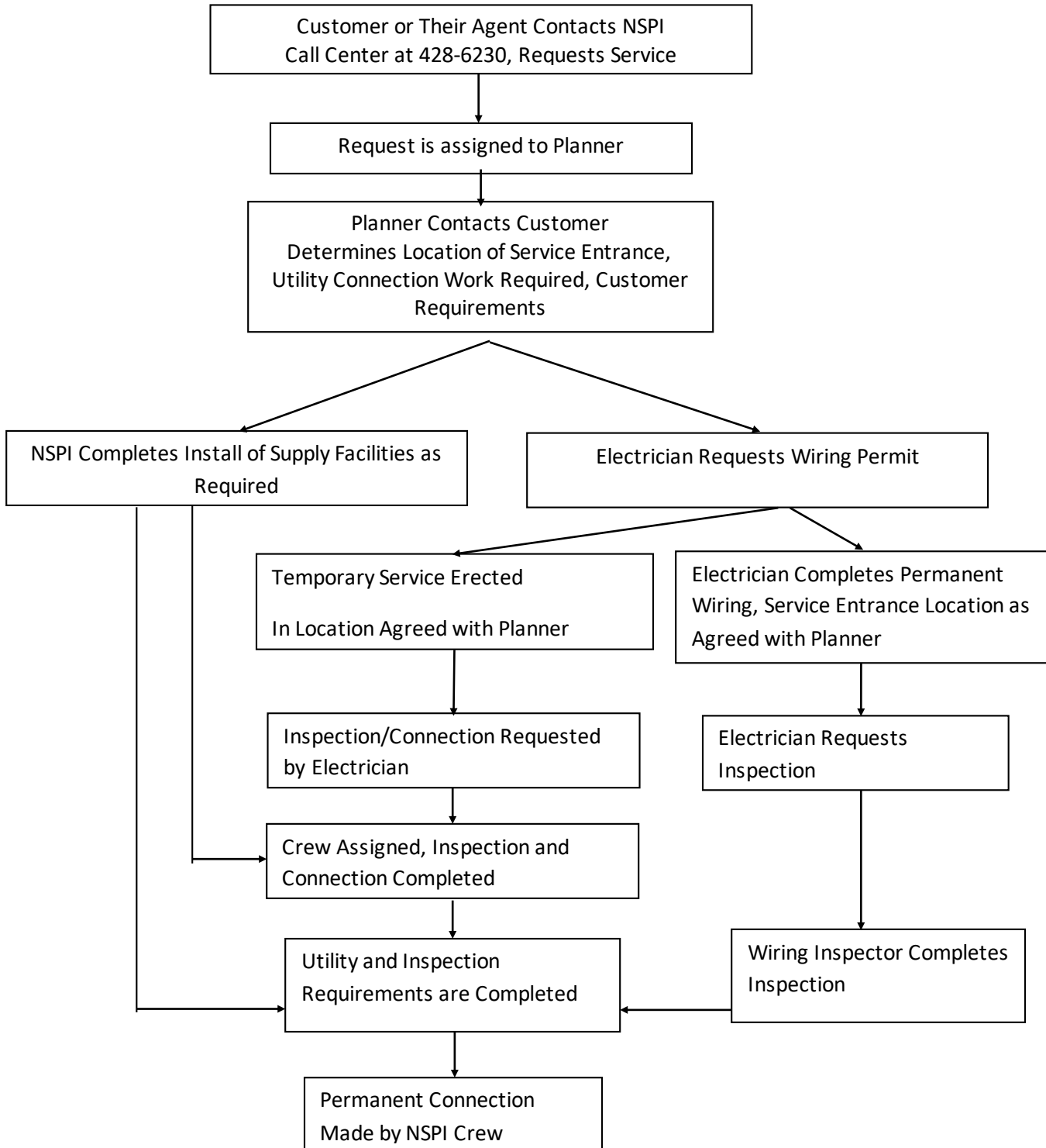

**NOVA SCOTIA POWER INC.
UTILITY SERVICE REQUIREMENTS**

**NOVA SCOTIA POWER INC.
UTILITY SERVICE REQUIREMENTS**

**APPENDIX A
SERVICE ENTRANCE AND METERING CONFIGURATIONS**

**NOVA SCOTIA POWER INC.
UTILITY SERVICE REQUIREMENTS**

NOVA SCOTIA POWER - DISTRIBUTION STANDARD

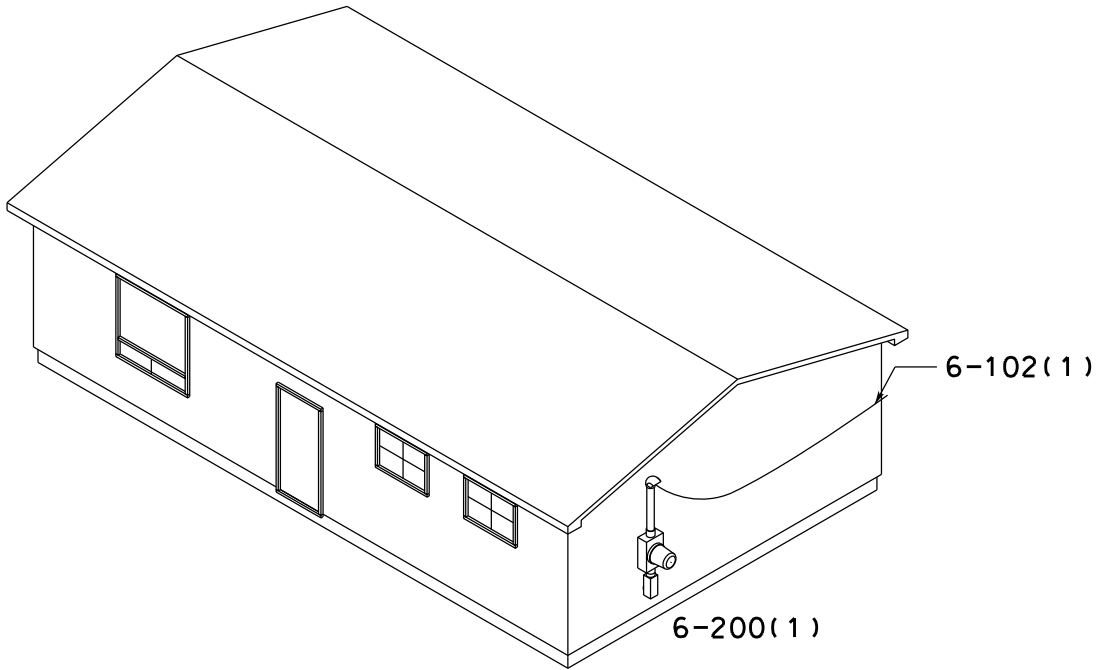

SINGLE FAMILY DWELLING

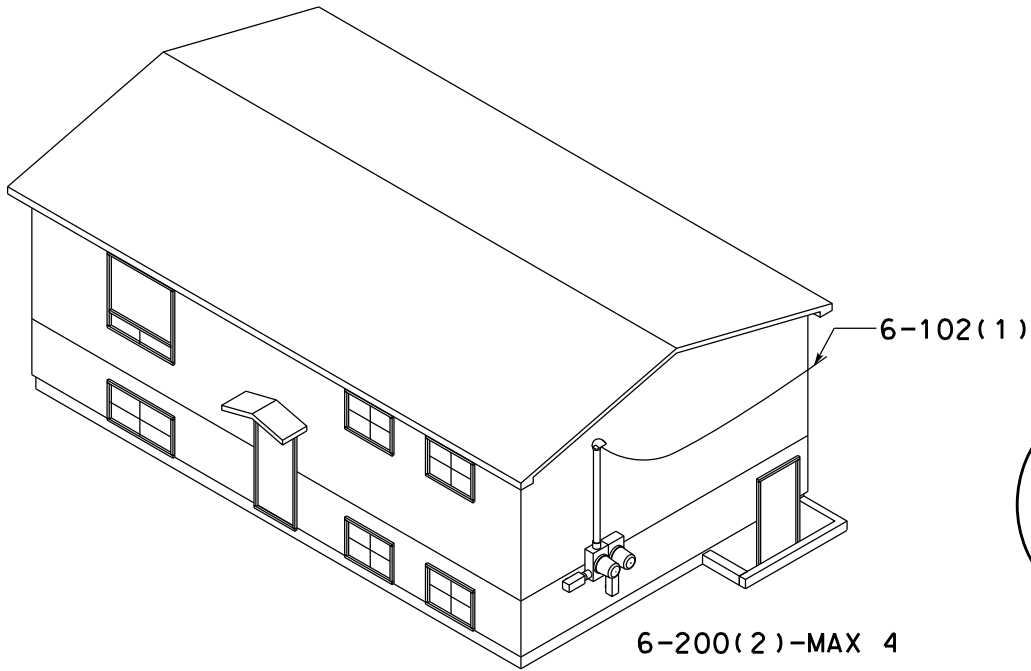

SINGLE FAMILY DWELLING
WITH
BASEMENT APARTMENT

REFERENCE



NSPI STANDARD DETAILS

SCALE **NTS** UNITS **NOTED** DRAWN **P.HUBLEY**
 CHECKED **J.MCFADGEN** DATE **2016-03-08** W.O. **XXXX**

SERVICE ENTRANCE AND
METERING CONFIGURATIONS
SINGLE OCCUPANCY

NSPI APPROVAL: *Jim McFadyen*

SS-SK-01M

REV
0

DWG.NO.

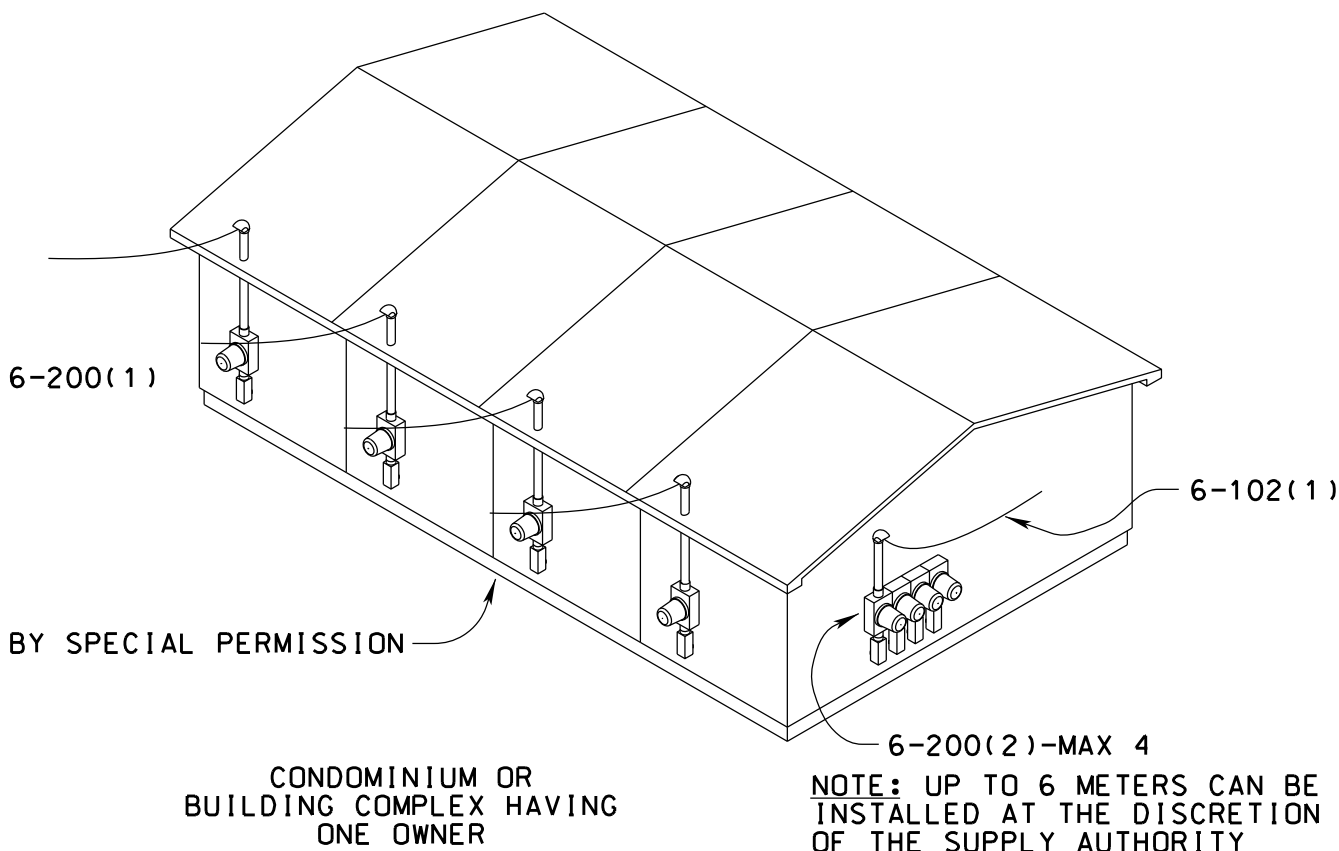
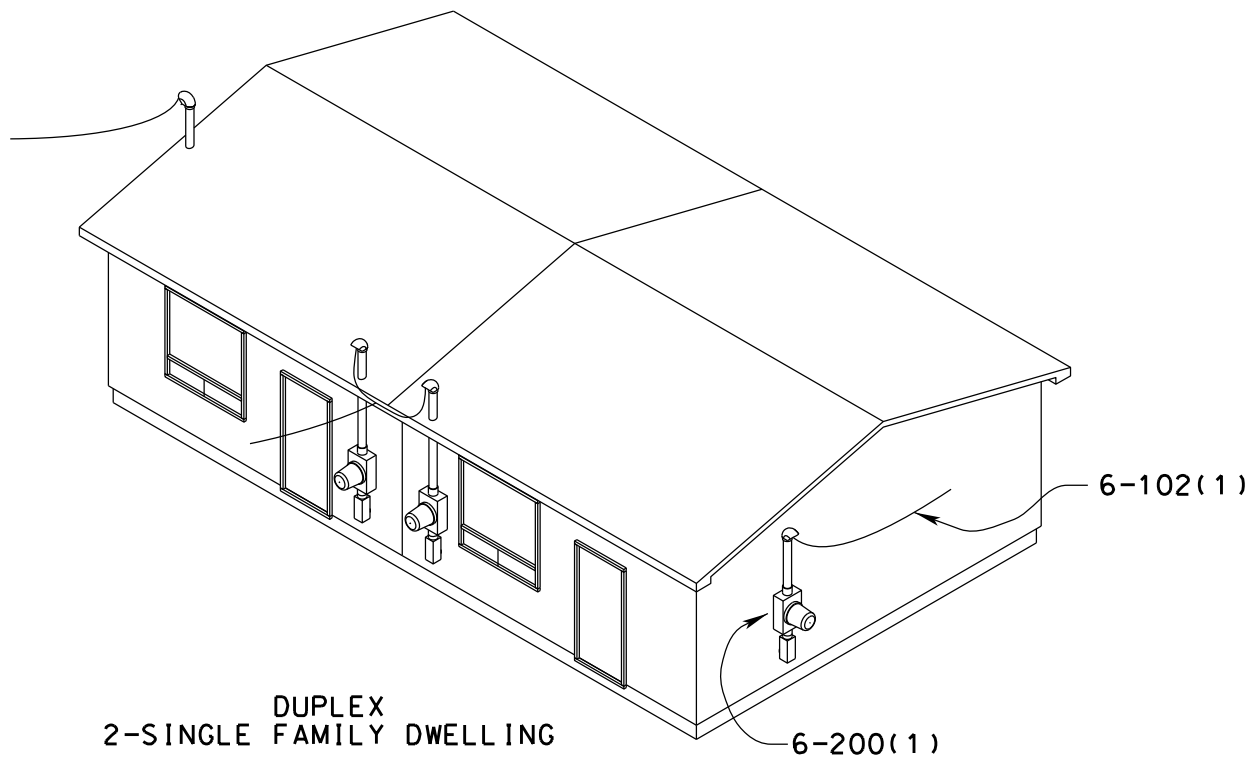

REFERENCE			 POWER An Emera Company
.....			
SCALE	NTS	UNITS NOTED	DRAWN P.HUBLEY
CHECKED	J.MCFADGEN	DATE 2016-03-08	W.O. XXXX
NSPI APPROVAL: <i>Justin Fudge</i>			SERVICE ENTRANCE AND METERING CONFIGURATIONS MULTIPLE OCCUPANCY
			REV 0

DWG.NO.

MULTIPLE OCCUPANCY

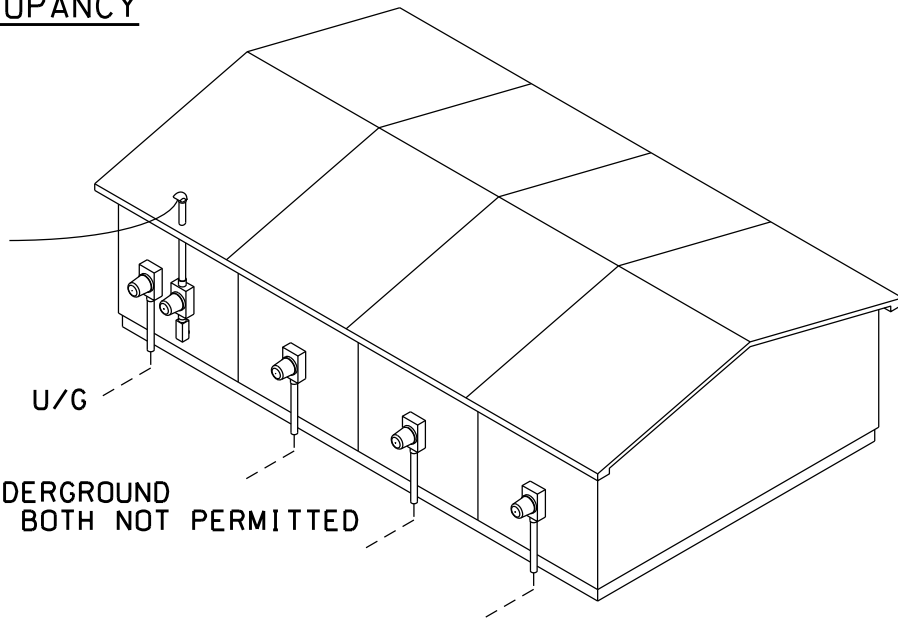

OVERHEAD OR UNDERGROUND
COMBINATION OF BOTH NOT PERMITTED

INDIVIDUAL OWNERSHIP
TOWNHOUSING - ROWHOUSING

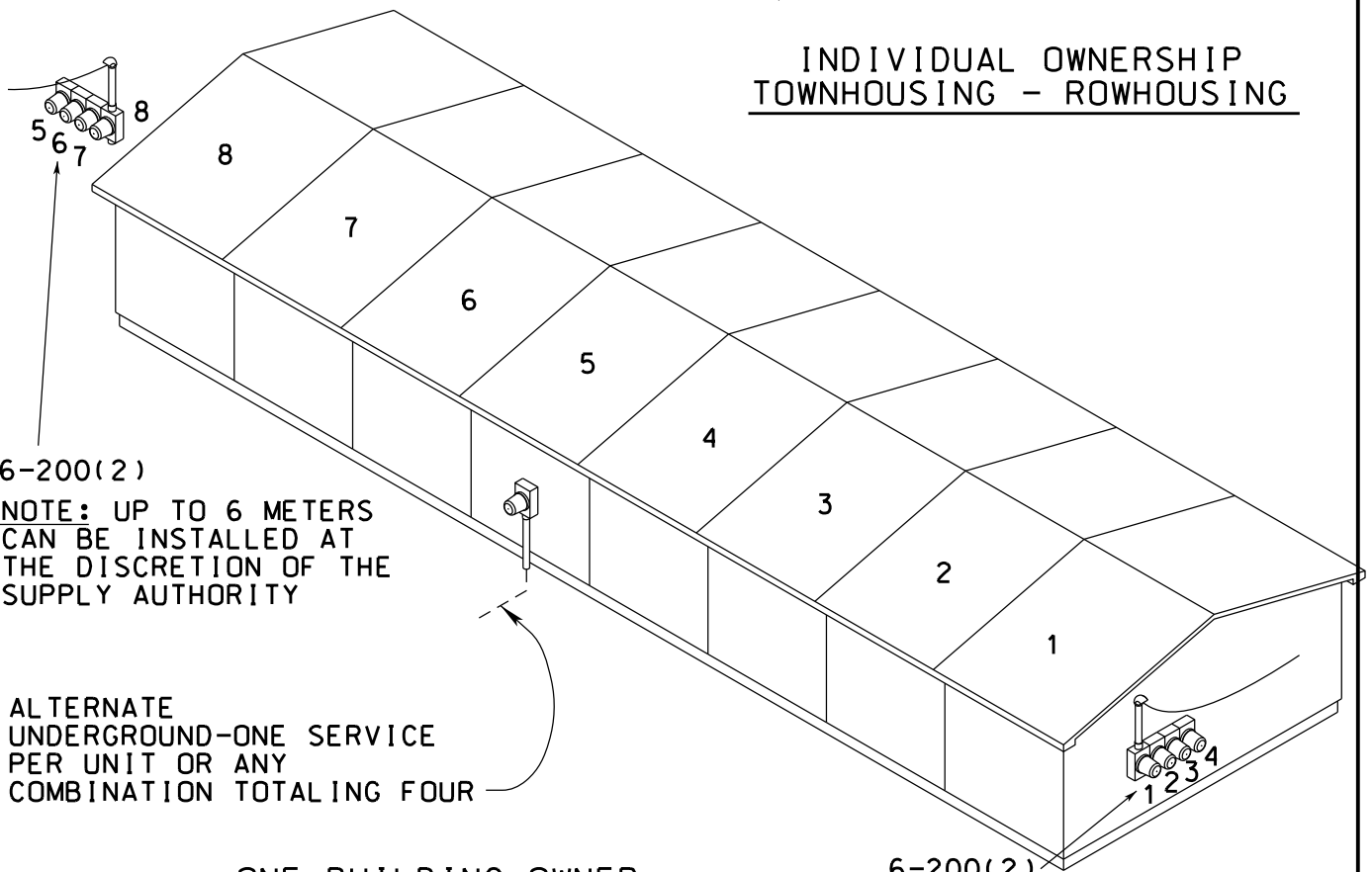

6-200(2)

NOTE: UP TO 6 METERS
CAN BE INSTALLED AT
THE DISCRETION OF THE
SUPPLY AUTHORITY

ALTERNATE
UNDERGROUND-ONE SERVICE
PER UNIT OR ANY
COMBINATION TOTALING FOUR

ONE BUILDING OWNER
NO INDIVIDUAL OWNERSHIP

6-200(2)

NOTE: UP TO 6 METERS CAN
BE INSTALLED AT THE
DISCRETION OF THE SUPPLY
AUTHORITY

REFERENCE



NSPI DISTRIBUTION STANDARD

SCALE **NTS** UNITS **NOTED** DRAWN **P.HUBLEY**
CHECKED **J.MCFADGEN** DATE **2016-03-08** W.O. **XXXX**

SERVICE ENTRANCE AND
METERING CONFIGURATIONS
MULTIPLE OCCUPANCY

NSPI APPROVAL: *John M. Fadyen*

SS-SK-03M

REV
0

DWG.NO.

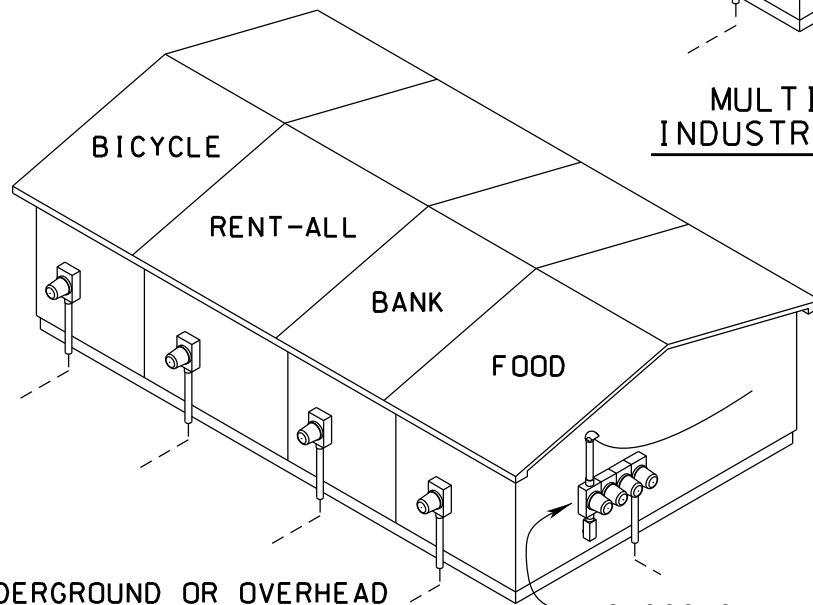
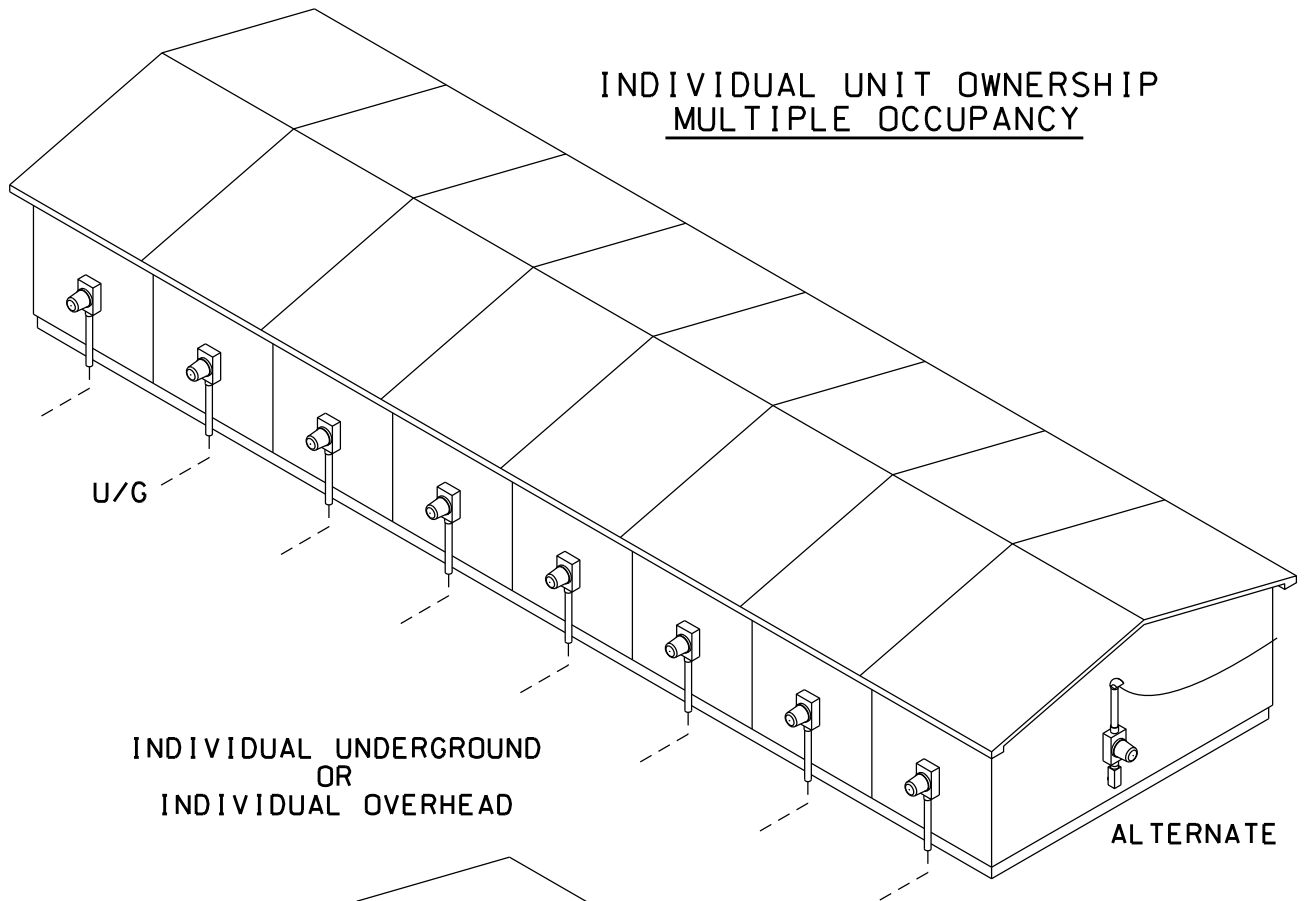

INDIVIDUAL UNDERGROUND OR OVERHEAD
MULTIMETER, MAX OF 4 OR 600A

NOTE: UP TO 6 METERS CAN
BE INSTALLED AT THE
DISCRETION OF THE SUPPLY
AUTHORITY

REFERENCE



NSPI DISTRIBUTION STANDARD

SCALE	NTS	UNITS NOTED	DRAWN	P.HUBLEY
CHECKED	J.MCFADGEN	DATE	2016-03-08	W.O. XXXX

**SERVICE ENTRANCE AND
METERING CONFIGURATIONS
MULTIPLE OCCUPANCY**

NSPI APPROVAL:

SS-SK-04M

REV	0
-----	----------

DWG.NO.

MALL COMPLEX INSTALLATION

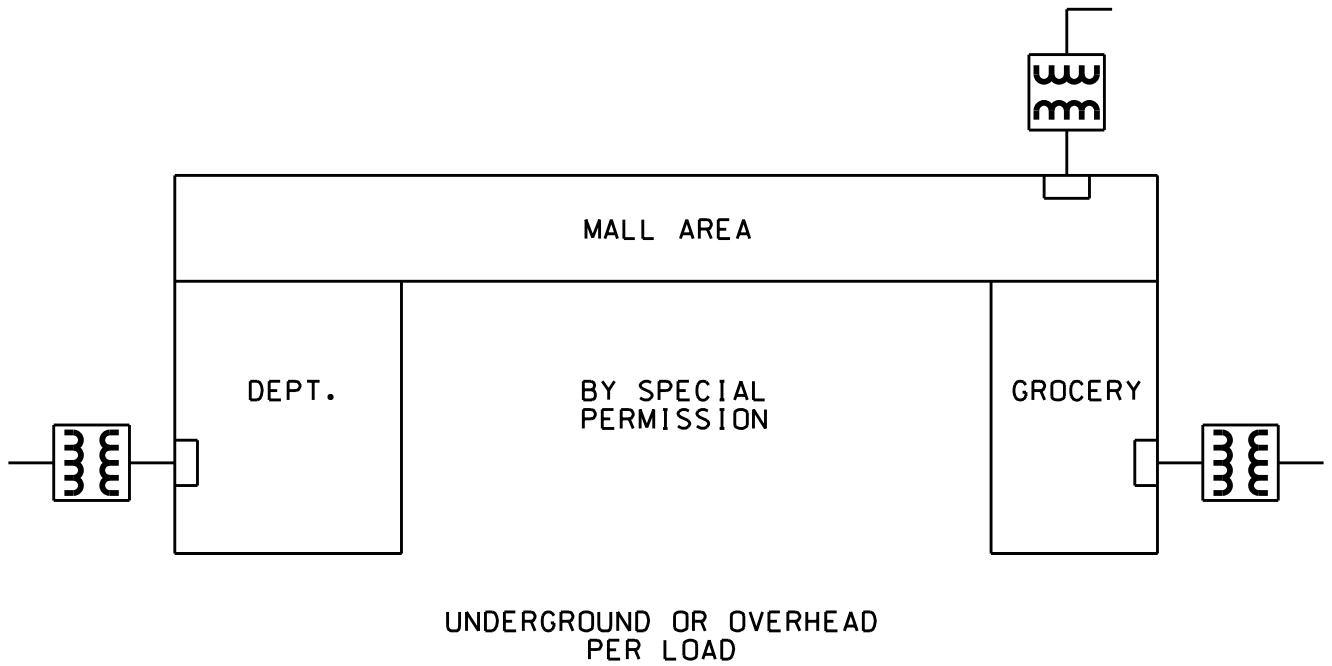

LARGE FACTORY

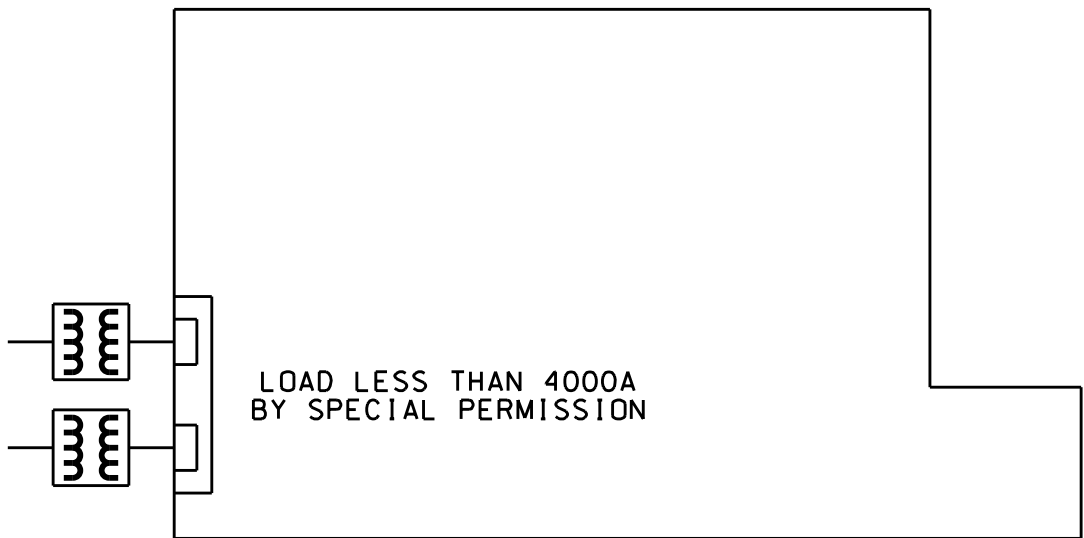

REFERENCE



NSPI DISTRIBUTION STANDARD

SCALE **NTS** UNITS **NOTED** DRAWN **P.HUBLEY**
 CHECKED **J.MCFADGEN** DATE **2016-03-08** W.O. **XXXX**

**SERVICE ENTRANCE AND
 METERING CONFIGURATIONS
 LARGE COMMERCIAL / INDUSTRIAL**

NSPI APPROVAL: *Justin Fudge*

SS-SK-05M

REV
0

DWG.NO.

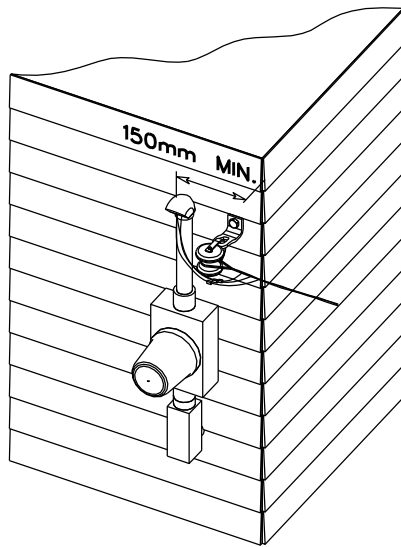

ACCEPTABLE

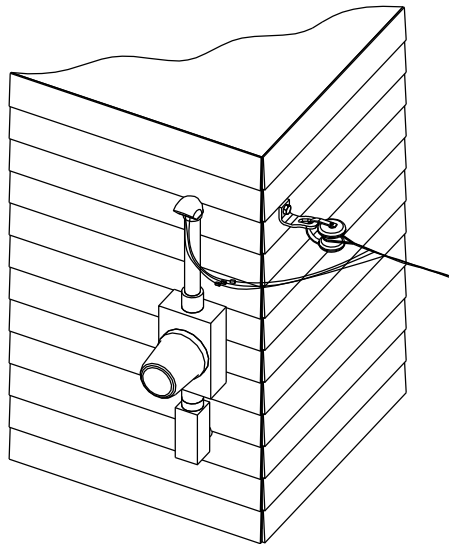

UNACCEPTABLE

NOTE:

REFER TO CLAUSE 12.7 (D) OF THE UTILITY SERVICES REQUIREMENTS BOOK.

REFERENCE
.....
.....



NSPI DISTRIBUTION STANDARD

SCALE	NTS	UNITS	NOTED	DRAWN	M. HALASZ
CHECKED	J. MCFADGEN	DATE	2016-03-08	W.O.	XXXX

SERVICE ENTRANCE CONFIGURATIONS

NSPI APPROVAL:

SS-SK-06M

REV	0
-----	----------

DWG.NO.

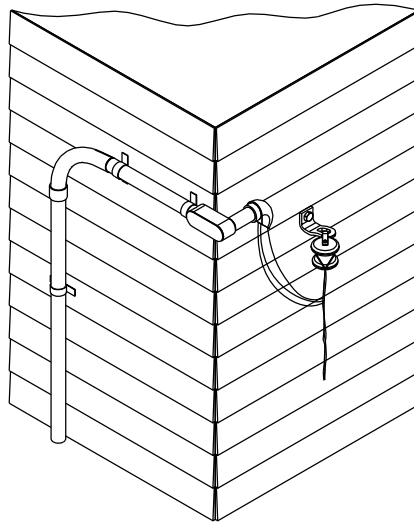

ISOMETRIC
NTS

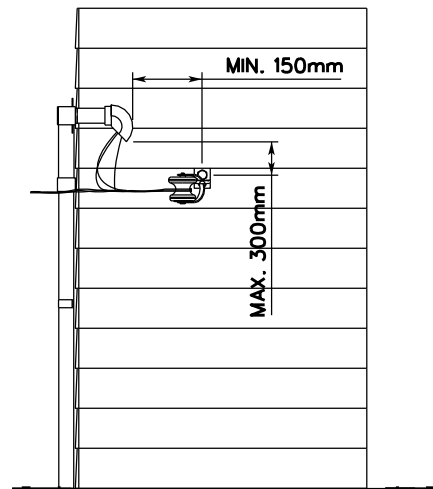

ELEVATION
NTS

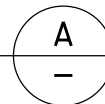

NOTE:

REFER TO CLAUSE 12.7 (D) OF THE UTILITY SERVICES REQUIREMENTS BOOK.

REFERENCE
.....
.....



NSPI DISTRIBUTION STANDARD

SCALE	NTS	UNITS	NOTED	DRAWN	M. HALASZ
CHECKED	J. MCFADGEN	DATE	2016-03-08	W.O.	XXXX

**SERVICE ENTRANCE CONFIGURATIONS
ALTERNATIVE 1**

NSPI APPROVAL: *Jim Fadyen*

SS-SK-07M

REV	0
-----	----------

DWG.NO.

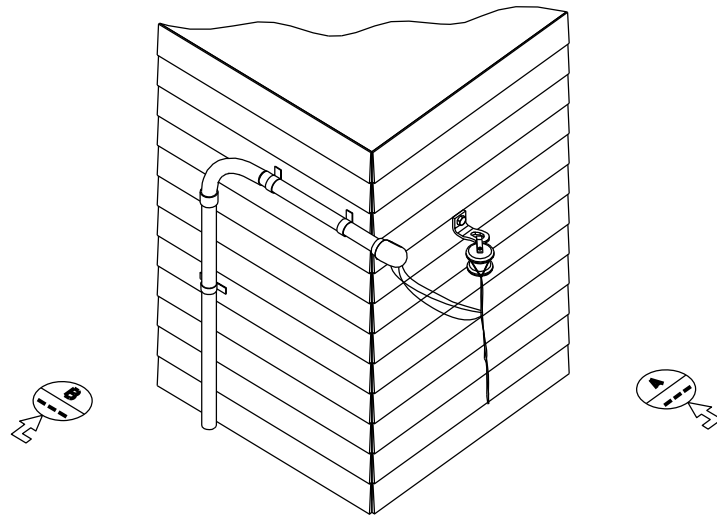

ISOMETRIC
NTS

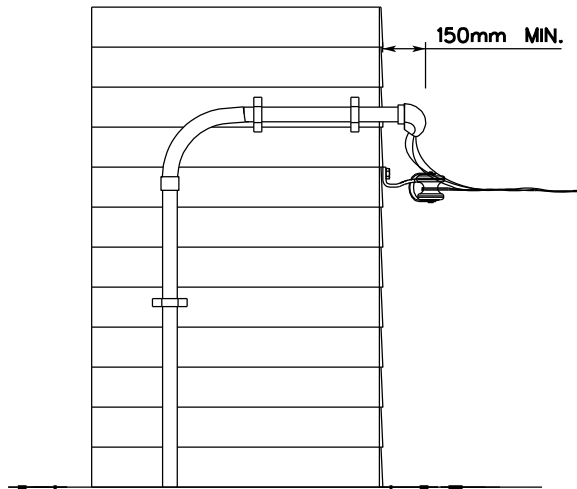

ELEVATION B
NTS

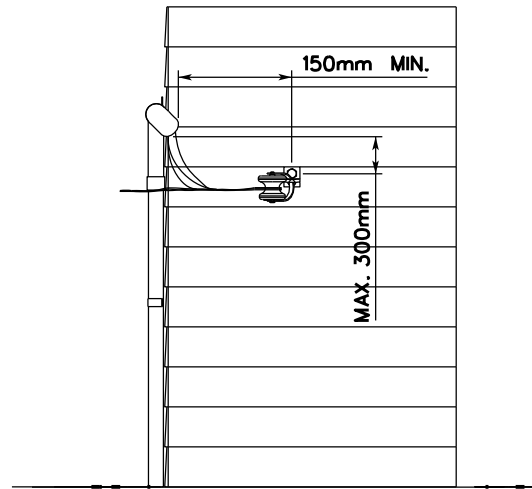

ELEVATION A
NTS

NOTES:

- 1.) THE MINIMUM DISTANCE FROM THE CORNER OF THE STRUCTURE TO THE TIP OF THE SERVICE ENTRANCE FITTING MUST BE 150mm.
- 2.) IF THERE WILL BE A DOWN SPOUT FOR A RAIN WATER COLLECTION SYSTEM ON THE SAME CORNER AS THE SERVICE, THEN THE DISTANCE MUST BE INCREASED SUCH THAT THE SERVICE ENTRANCE CONDUCTORS WILL NOT BE TOUCHING THE DOWN SPOUT.
- 3.) ALL DIMENSIONS IN RELATION TO THE POSITION OF THE SERVICE ENTRANCE TO THE POINT OF ATTACHMENT OF THE SUPPLY CABLES WILL BE MEASURED ON THE SIDE OF THE STRUCTURE WHERE THE SUPPLY CABLE IS ATTACHED.
- 4.) IF THERE ARE MORE THAN ONE CONDUIT ON A SERVICE ENTRANCE, THEN ALL WEATHER HEADS MUST PROTRUDE THE SAME AMOUNT FROM THE CORNER OF THE STRUCTURE.

REFERENCE



NSPI DISTRIBUTION STANDARD

SCALE	NTS	UNITS NOTED	DRAWN	M. HALASZ
CHECKED	J. MCFADGEN	DATE	2016-03-08	W.O. XXXX

SERVICE ENTRANCE CONFIGURATIONS
ALTERNATIVE 2

NSPI APPROVAL: *Justin Fadyen*

SS-SK-08M

REV
0

DWG.NO.

**NOVA SCOTIA POWER INC.
UTILITY SERVICE REQUIREMENTS**

**APPENDIX B
NSPI STANDARD DRAWINGS**

**NOVA SCOTIA POWER INC.
UTILITY SERVICE REQUIREMENTS**

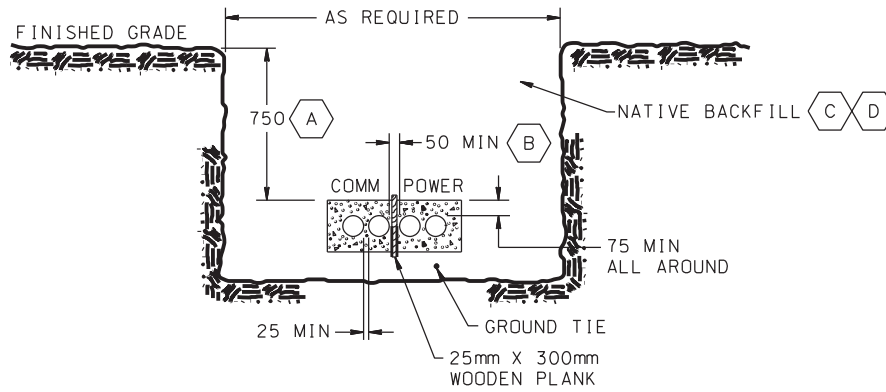

CONCRETE ENCASED DUCTS

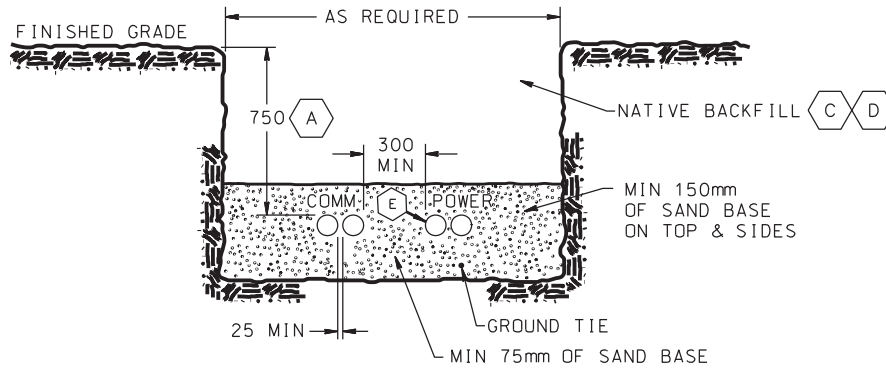

DIRECT BURIED DUCTS

NOTES:

- A. DEPTH SHALL BE INCREASED TO 1000 mm IN VEHICULAR AREAS. MAY BE REDUCED TO 600 mm IF VOLTAGE DOES NOT EXCEED 750 VOLTS PHASE TO PHASE.
- B. MUST BE INCREASED TO 300 mm IF ONE UTILITY'S DUCTS ARE NOT CONCRETE ENCASED.
- C. NATIVE BACKFILL MATERIAL SHALL NOT CONTAIN ROCKS OVER 50 mm IN DIAMETER FOR THE FIRST 300 mm OVER DUCTS OR CABLES. CLASS 'A' GRAVEL IS ACCEPTABLE.
- D. BACKFILL TO BE COMPACTED EVERY 300 mm MINIMUM.
- E. IF POWER CABLES OPERATING AT DIFFERENT VOLTAGES ARE INSTALLED IN THE SAME TRENCH THE LOWEST VOLTAGE CABLES SHALL BE INSTALLED ADJACENT TO THE COMMUNICATIONS CIRCUIT.
- F. ALL CROSSINGS OF THE COMMUNICATIONS AND NSPI DUCTS SHALL BE AT RIGHT ANGLES WITH A MINIMUM CLEARANCE OF 300 mm.
- G. NUMBER, SIZE AND TYPE OF CONDUIT/DUCTS TO BE SPECIFIED BY THE USER UTILITY.
- H. ALL DIMENSIONS ARE IN MILLIMETRES UNLESS OTHERWISE SHOWN.



DISTRIBUTION UNDERGROUND STANDARDS



JOINT USE TRENCH DETAILS

DATE: 2008-08-14	REV DATE: 2008-08-14
DRAWN: H. V. HUYNH	STD NO: 1U-ED-12M
APPROVED: <i>Justin Fudge</i>	SHEET: 1 of 1 (R1)

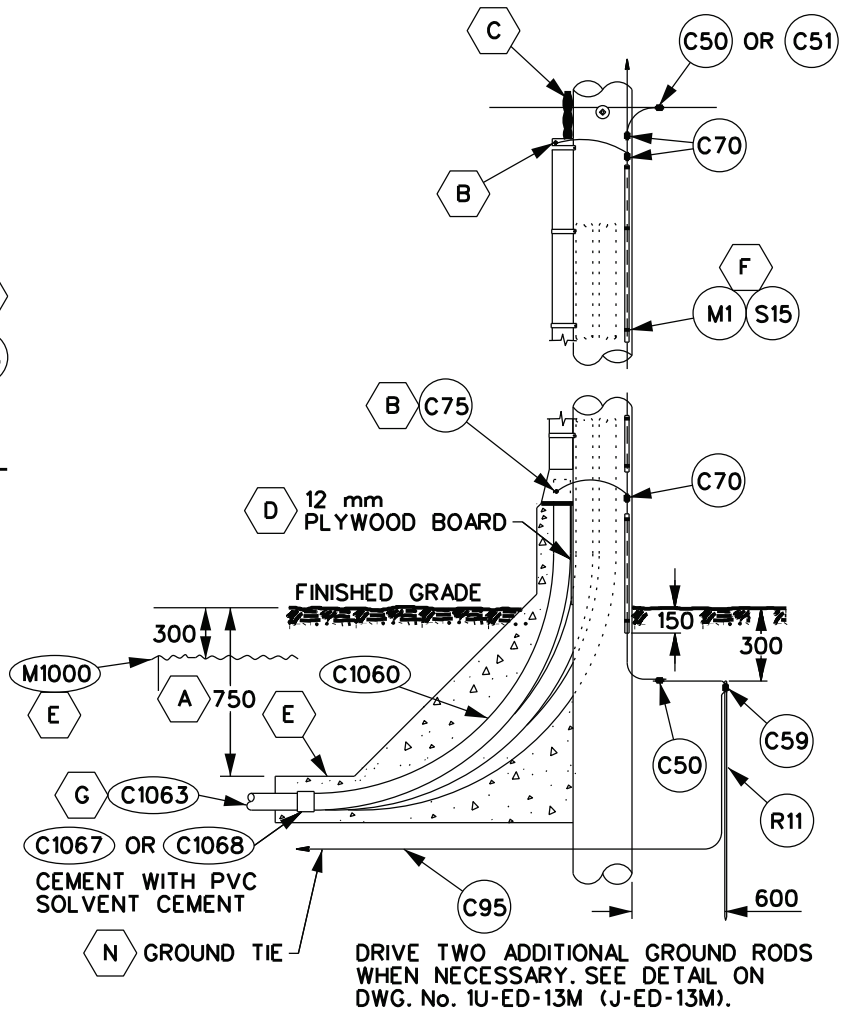
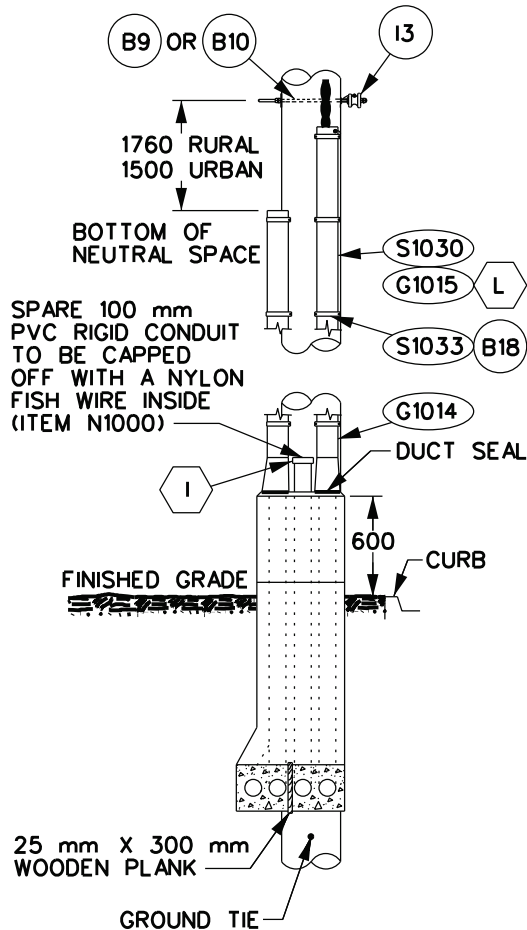
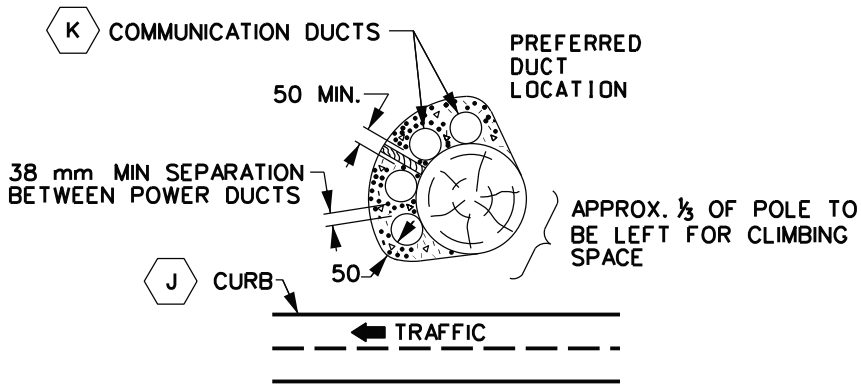

DRIVE TWO ADDITIONAL GROUND RODS WHEN NECESSARY. SEE DETAIL ON DWG. No. 1U-ED-13M (J-ED-13M).

(SAME AS J-ED-14M)

Arthur Ormiston
NSPI APPROVAL:

Arthur Ormiston
AR60851
BELL APPROVAL:

Digitally signed by Arthur Ormiston AR60851 Date: 2017.03.28 19:26:57 -0300

DISTRIBUTION STANDARDS JOINT-USE



JOINT USE DUCT TERMINATION FOR UNDERGROUND PRIMARY SERVICE (MORE THAN 750 VOLTS)

DATE:	1993-07-01	REV DATE:	2016-11-16
DRAWN:	M. HALASZ	STD NO:	1U-ED-14M
APPROVED:	<i>John Halasz</i>	SHT NO:	1 OF 2 (R2)

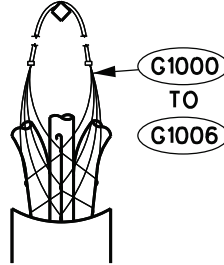



DETAIL OF KELLEMS GRIP

NOTES:

- A. FOR ROADWAY/DRIVEWAY REQUIREMENTS, DEPTH OF BURIAL TO BE 1000 mm. (NSPI: REFER TO DWG. No. 1U-ED-44M).
- B. REFER TO DWG. No. 10U-ED-12M FOR BONDING OF POWER CABLE GUARDS.
- C. REFER TO SECTION '5U' FOR OVERHEAD POWER TERMINATION DETAILS.
- D. DUCTS SHALL BE SECURED TO THE POLE WITH CONDUIT STRAPS AND HAVE A 12 mm THICK PLYWOOD BOARD SPACER BEFORE CONCRETE IS POURED.
- E. DUCT RUNS SHALL BE FORMED BY THE CUSTOMER OR HIS AGENT AND INSEPECTED BY NSPI AND COMMUNICATION REPRESENTATIVES PRIOR TO POURING OF CONCRETE, MARKER TAPE TO BE INSTALLED AS SHOWN.
- F. GROUND WIRE MOULDING TO BE STAPLED TO POLE EVERY 600 mm.
- G. 100 mm DUCTS SHALL NORMALLY BE USED BY NSPI. IN SPECIAL CIRCUMSTANCES, WHEN MORE THAN THREE 90° BENDS ARE NEEDED BETWEEN CABLE PULLING POINTS, OR DUCT RUN EXCEEDS 92 m, 125 mm DUCTS SHALL BE USED.
- H. ANY METAL USED FOR FORMING CONCRETE AT THE BASE OF POLE SHALL BE REMOVED.
- I. ALL DUCTS MUST BE CLEANED AND SWABBED, THEN CAPPED FOR PROTECTION.
- J. DUCTS SHALL NOT BE INSTALLED ON THE CURB OR TRAFFIC SIDE OF THE POLE.
- K. ON DEADEND STRUCTURES THE POSITION OF THE DUCTS MAY BE REVERSED TO FACILITATE COMMUNICATIONS DEADENDING.
- L. STRAP CABLED UNDER GUARD EVERY 3000 mm AND CABLE GUARD TO POLE EVERY 1200 mm.
- M. NUMBER, SIZE AND TYPE OF CONDUITS/DUCTS TO BE SPECIFIED BY THE USER UTILITY.
- N. GROUND TIE TO BE INSTALLED BENEATH THE DUCTBANK AND CONNECTED TO THE DOWN STREAM DISTRIBUTION EQUIPMENT GROUND.
- M. ALL DIMENSIONS ARE IN MILLIMETERS UNLESS OTHERWISE SHOWN.

(SAME AS J-ED-14M)

 NSPI APPROVAL: Arthur Ormiston AR60851 Date: 2017.03.28 19:28:32 -0500 BELL APPROVAL:	DISTRIBUTION STANDARDS JOINT-USE		 Nova Scotia POWER An Emera Company	
	JOINT USE DUCT TERMINATION FOR UNDERGROUND PRIMARY SERVICE (MORE THAN 750 VOLTS)			
DATE:	1993-07-01	REV DATE:	2016-11-16	
DRAWN:	M. HALASZ	STD NO:	1U-ED-14M	
APPROVED:		SHT NO:	2 OF 2 (R2)	

JOINT USE DUCT TERMINATION FOR UNDERGROUND SECONDARY SERVICES (750 VOLTS OR LESS)

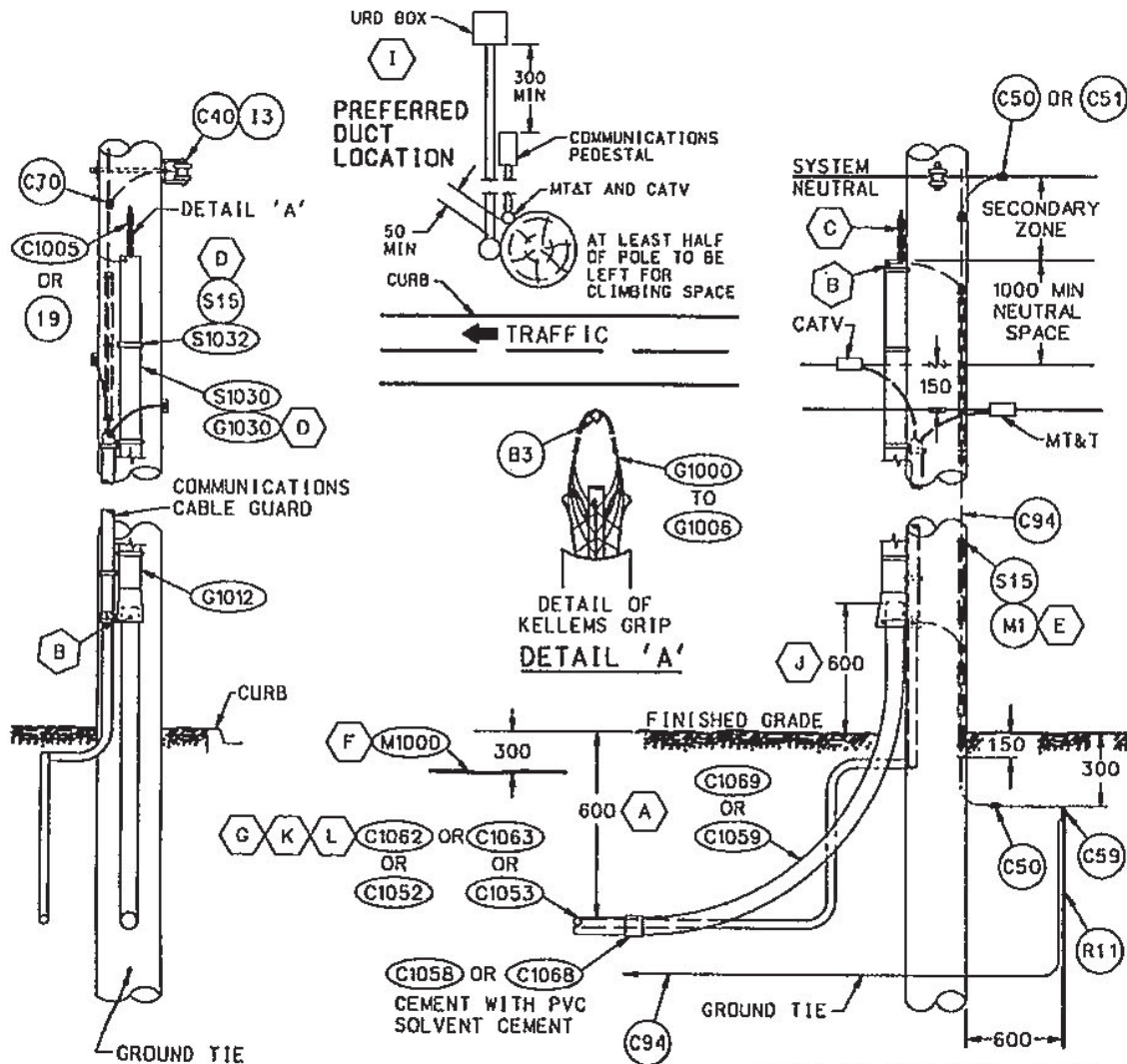

NOTES:

- A. DEPTH SHALL BE INCREASED TO 1000mm IN VEHICULAR AREAS (REFER TO DWG. NO. 1U-ED-44M).
- B. REFER TO DWG. NO. 10U-ED-12M FOR BONDING OF POWER CABLE GUARDS.
- C. REFER TO SECTION '5U' FOR OVERHEAD POWER TERMINATION DETAILS.
- D. STRAP CABLES UNDER GUARD EVERY 3000mm AND CABLE GUARD TO POLE EVERY 1200mm.
- E. GROUND WIRE MOULDING TO BE STAPLED TO POLE EVERY 600mm.
- F. MARKER TAPE (ITEM M1000) SHALL BE INSTALLED AS SHOWN.
- G. ALL CONDUITS AND FITTINGS SHALL BE CSA APPROVED. CONDUIT RUNS SHALL BE CONSTRUCTED BY THE CUSTOMER OR HIS AGENT AND INSPECTED BY NSP AND MT&T REPRESENTATIVES PRIOR TO BACKFILLING.
- H. REFER TO DWG. NO. 1U-ED-12M FOR SERVICE TRENCH DETAILS.
- I. NSP: REFER TO DWG. NO. 7U-ED-21M FOR CONDUIT AND URD BOX LOCATION. CONDUITS SHALL NOT BE INSTALLED ON THE CURB OR TRAFFIC SIDES OF THE POLE.
- J. RIGID PVC CONDUIT TO EXTEND UP THE POLE 600mm WITH CABLE GUARD OVERLAPPING THE CONDUIT.
- K. ALL CONDUIT MUST BE CLEANED AND SWABBED THEN CAPPED FOR PROTECTION.
- L. ALL CONDUIT SHALL HAVE A NYLON FISH LINE (ITEM N1000) INSTALLED PRIOR TO CAPPING.
- M. NUMBER, SIZE AND TYPE OF CONDUITS/DUCTS TO BE SPECIFIED BY THE USER UTILITY.
- N. ALL DIMENSIONS ARE IN MILLIMETRES UNLESS OTHERWISE SPECIFIED.

drawn Craig J. Fair designed W. H. King approved W. H. King NSP
 uSTH FILE NAME: UGS<300,0301U-ED25M.DGN
B. White S. M. M. MT&T

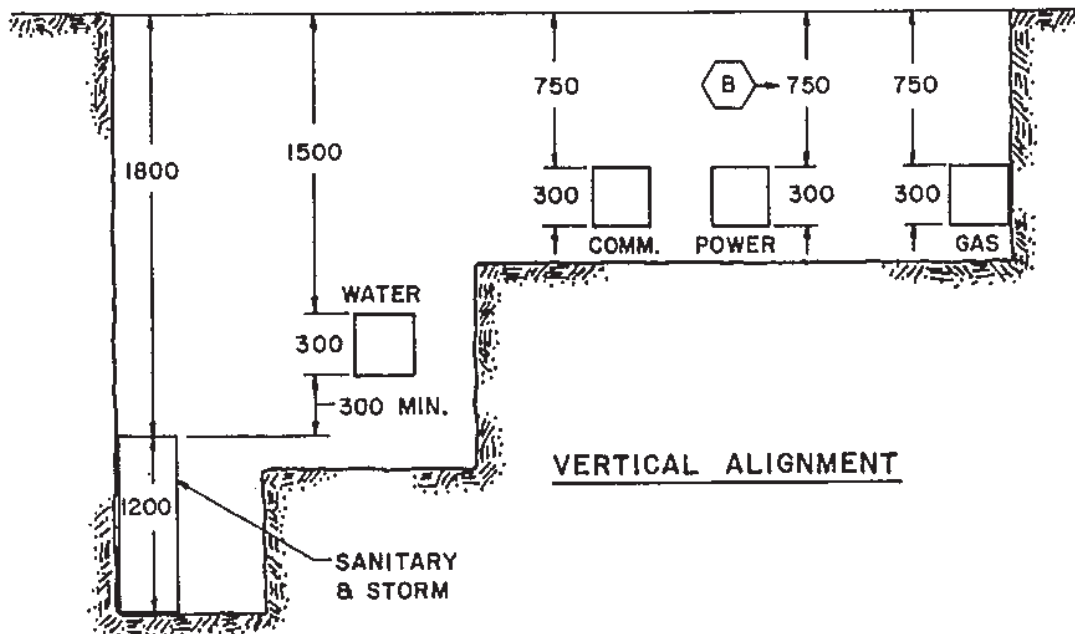
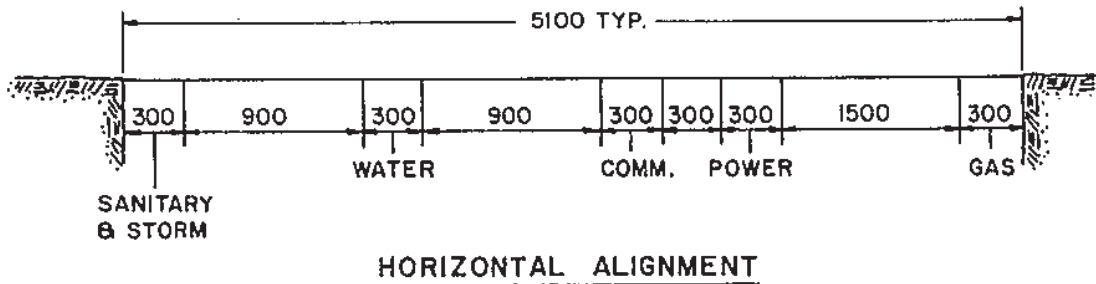

NOTES:

- A. ALL DIMENSIONS GIVEN ARE PREFERRED, BUT MAY BE REDUCED DUE TO EARTH CONDITIONS (I.E. BEDROCK) WITH THE PRIOR WRITTEN APPROVAL OF ALL UTILITIES CONCERNED.
- B. REFER TO DWG. NO. 1U-ED-44M FOR ROADWAY/DRIVEWAY REQUIREMENTS. MAY BE REDUCED TO 600mm IF VOLTAGE DOES NOT EXCEED 750 VOLTS PHASE TO PHASE.
- C. ALL CROSSINGS SHALL BE AT RIGHT ANGLES WITH A MINIMUM CLEARANCE OF 300 mm.
- D. ALL DIMENSIONS ARE IN MILLIMETRES UNLESS OTHERWISE SHOWN.

drawn Carey H. Feary designed Laura J. Feary approved Bonathur
Standards Committee

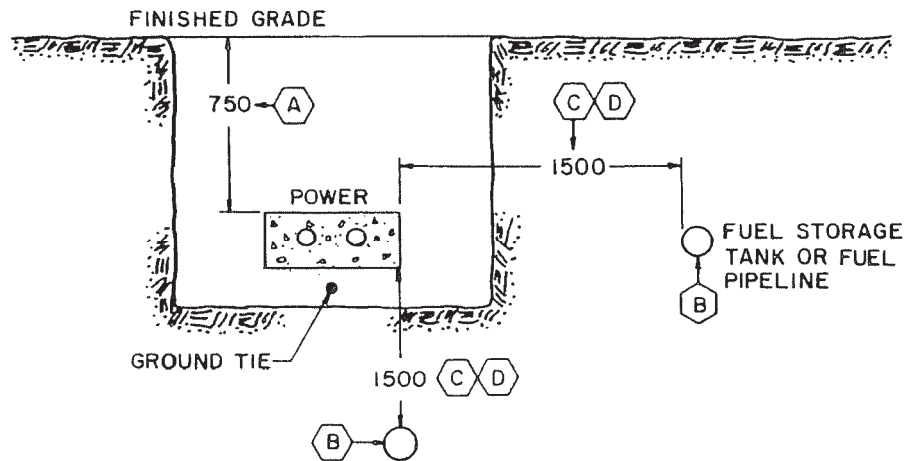

NOTES:

- A . REFER TO DWG. NO. IU-ED-44M FOR ROADWAY/DRIVEWAY REQUIREMENTS
MAY BE REDUCED TO 600 mm IF VOLTAGE DOES NOT EXCEED 750 VOLTS
PHASE TO PHASE .
- B . FUEL STORAGE APPLIES TO OIL , PROPANE OR GASOLINE TANKS OR PIPELINES
- C . 1500 mm IS THE REQUIRED CLEARANCE WHETHER THE DUCTS ARE CONCRETE
ENCASED OR DIRECT BURIED .
- D . MAY BE REDUCED TO 600 mm WHERE THE FUEL STORAGE TANK HOLDS LESS
THAN 7600 LITRES .
- E . UNDERGROUND POWER CABLES SHALL NOT BE ROUTED UNDER STORAGE
TANKS CONTAINING FLAMMABLE LIQUIDS OR GAS .
- F . ALL DIMENSIONS ARE IN MILLIMETRES UNLESS OTHERWISE SHOWN .



**DISTRIBUTION
UNDERGROUND
STANDARDS**



**MINIMUM CLEARANCE BETWEEN
POWER DUCTS
AND FUEL STORAGE TANKS OR PIPE LINES**

DATE: 2008-09-15	REV DATE: 2016-04-11
DRAWN: H. V. HUYNH	STD NO: 1U-ED-41M.
APPROVED: <i>J. V. Tawil</i>	SHEET: 1 of 1 (R1)

MINIMUM CLEARANCES BETWEEN
POWER DUCTS AND PIPELINES

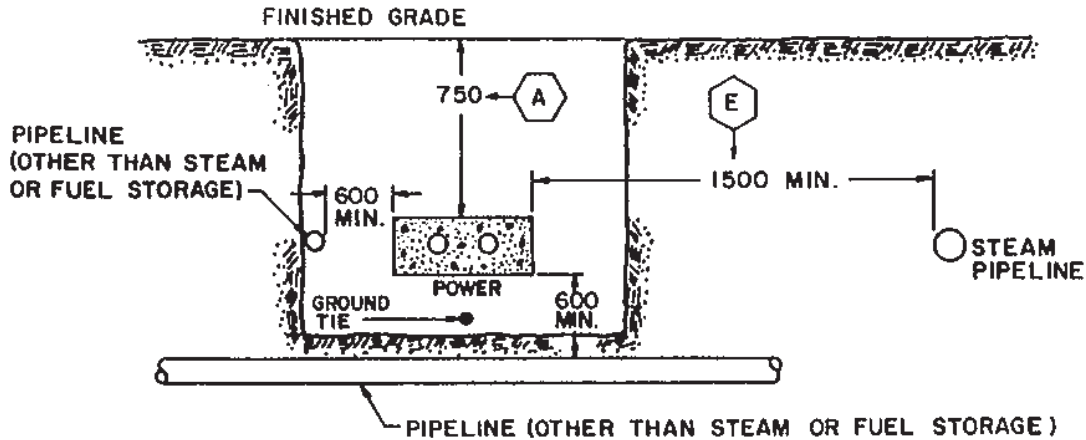

NOTES:

- A. REFER TO DWG. NO. 1U-ED-44M FOR ROADWAY/DRIVEWAY REQUIREMENTS. MAY BE REDUCED TO 600 mm IF VOLTAGE DOES NOT EXCEED 750 VOLTS PHASE TO PHASE.
- B. ALL CROSSINGS SHALL BE AT RIGHT ANGLES WITH A MINIMUM CLEARANCE OF 600 mm.
- C. THE MINIMUM CONCRETE COVER OVER THE DUCTS SHALL BE 75 mm AND SHALL HAVE A MINIMUM STRENGTH OF 20 MPa @ 28 DAYS.
- D. IF THE WIDTH OF THE DUCTBANK EXCEEDS 550 mm, THEN ADDITIONAL STRENGTHENING MAY BE REQUIRED AS DEFINED IN CSA STANDARD C22.3, NO. 7-M.
- E. FOR PARALLEL STEAM LINES THE GREATER THE SEPARATION FROM POWER CABLES THE BETTER, AS STEAM LINES ARE A MAJOR SOURCE OF CABLE HEATING WHEN PRESENT.
- F. ALL CLEARANCES APPLY TO DIRECT BURIED OR CONCRETE ENCASED DUCTS. THE CABLE SHALL BE INSTALLED AT A UNIFORM DEPTH FOR THE FULL WIDTH OF RIGHT-OF-WAY CONCERNED.
- G. ALL DIMENSIONS ARE IN MILLIMETRES UNLESS OTHERWISE SHOWN.

drawn Gregory Fein designed Perry Mason approved Ed Mathew
Standards Committee

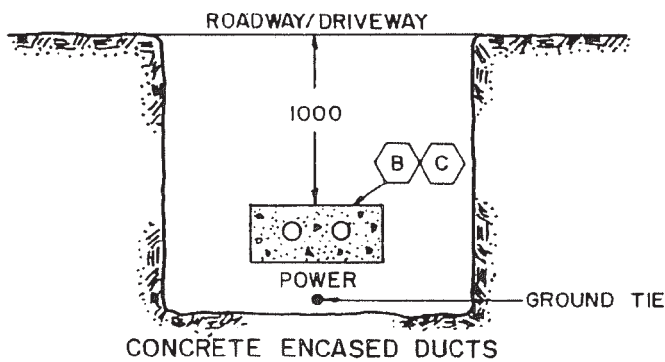
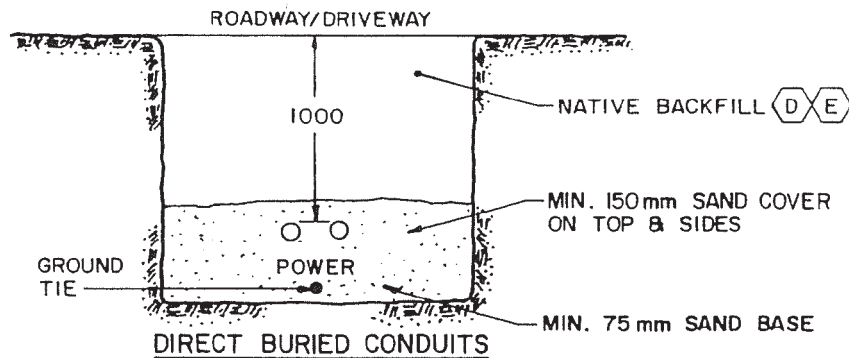

NOTES:

- A . ALL CROSSINGS SHALL BE AT RIGHT ANGLES WITH A MINIMUM CLEARANCE OF 300 mm .
- B . THE MINIMUM CONCRETE COVER OVER THE DUCTS SHALL BE 75 mm AND SHALL HAVE A MINIMUM STRENGTH OF 20 MPa @ 28 DAYS .
- C . IF THE WIDTH OF THE DUCTBANK EXCEEDS 550 mm , THEN ADDITIONAL STRENGTHENING MAY BE REQUIRED AS DEFINED IN CSA STANDARD C22.3 , No. 7-M .
- D . NATIVE BACKFILL MATERIAL SHALL NOT CONTAIN ROCKS OVER 50 mm IN DIAMETER FOR THE FIRST 300 mm OVER DUCTS OR CABLES . CLASS 'A' GRAVEL IS ACCEPTABLE .
- E . BACKFILL TO BE COMPACTED EVERY 300 mm .
- F . WHERE THE DUCTBANK/CONDUIT IS INSTALLED BENEATH A DRAINAGE DITCH THE MINIMUM DEPTH OF BURIAL SHALL BE MAINTAINED FROM THE BOTTOM OF THE DRAINAGE DITCH .
- G . ALL DIMENSIONS ARE IN MILLIMETRES UNLESS OTHERWISE SHOWN .



DISTRIBUTION UNDERGROUND STANDARDS



MINIMUM CLEARANCES UNDER ROADWAYS/DRIVEWAYS

DATE: 2008-09-15	REV DATE: 2016-04-11
DRAWN: H. V. HUYNH	STD NO: 1U-ED-44M
APPROVED: <i>Justin Fudge</i>	SHEET: 1 of 1 (R1)

MINIMUM CLEARANCES BETWEEN
POWER DUCTS AND SWIMMING POOLS

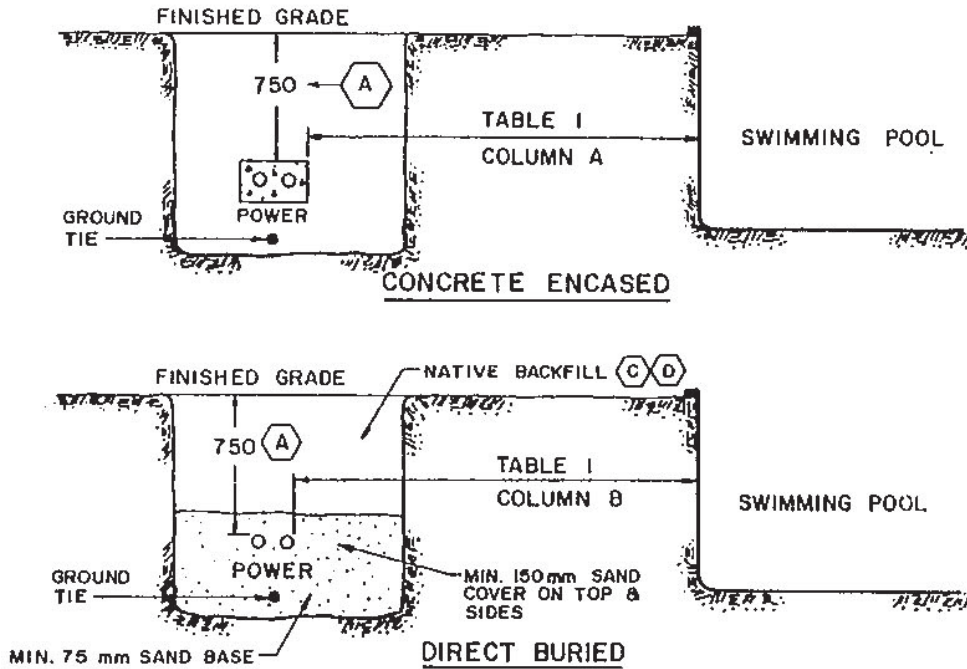

TABLE I		
VOLTAGE (B)	COLUMN A	COLUMN B
0 - 750 V	750	1500
750 V - 15 kV	1500	3000
15 kV - 22 kV	2000	4000

NOTES:

- A . REFER TO DWG. NO. IU-ED-44M FOR ROADWAY/DRIVEWAY REQUIREMENTS . MAY BE REDUCED TO 600 mm IF VOLTAGE DOES NOT EXCEED 750 VOLTS PHASE TO PHASE .
- B . VOLTAGES ARE RMS PHASE TO GROUND .
- C . NATIVE BACKFILL MATERIAL SHALL NOT CONTAIN ROCKS OVER 50 mm IN DIAMETER FOR THE FIRST 300 mm OVER DUCTS OR CABLES . CLASS 'A' GRAVEL IS ACCEPTABLE .
- D . BACKFILL TO BE COMPACTED EVERY 300 mm MINIMUM .
- E . ALL DIMENSIONS ARE IN MILLIMETRES UNLESS OTHERWISE SHOWN .

drawn Greg J. Fahey designed Tim Moore approved Smather
Standards Committee

SINGLE PHASE PADMOUNT TRANSFORMER TRENCH DETAILS

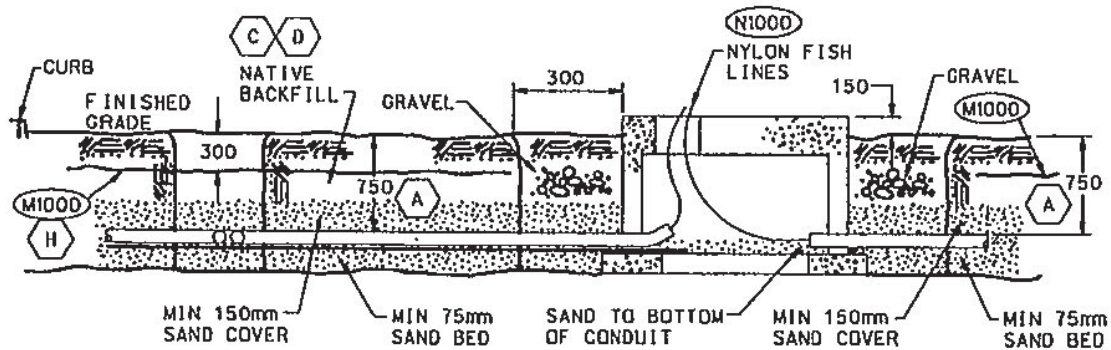
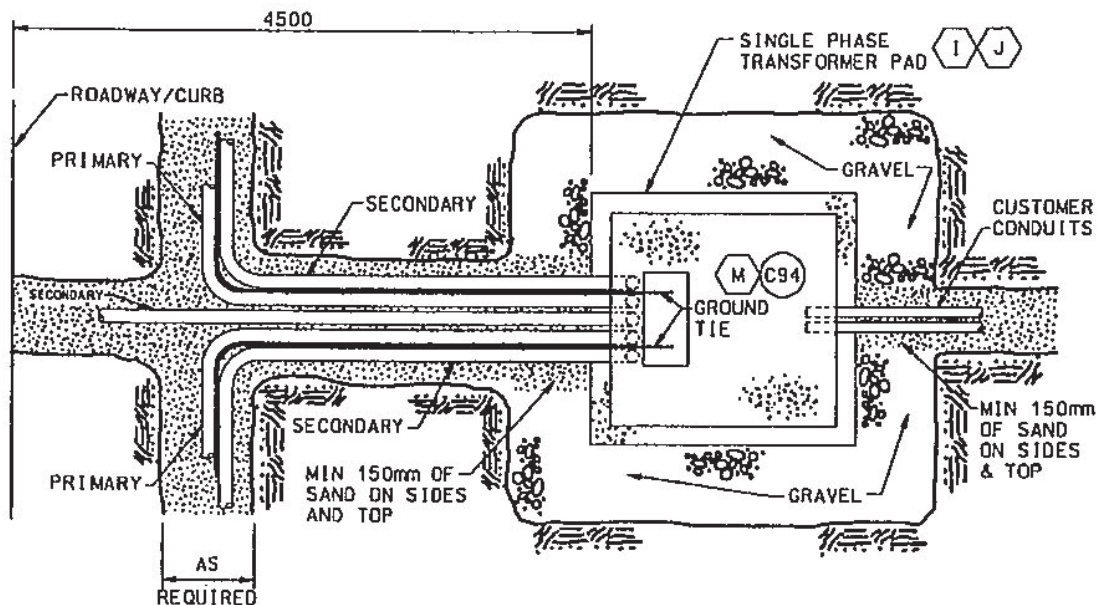

NOTES:

- A. REFER TO DWG. NO. 1U-ED-44M FOR ROADWAY/DRIVEWAY REQUIREMENTS. MAY BE REDUCED TO 600mm IF VOLTAGE DOES NOT EXCEED 750 VOLTS PHASE TO PHASE.
- B. CONDUIT TO BE BEDDED WITH SAND AS SHOWN.
- C. NATIVE BACKFILL MATERIAL SHALL NOT CONTAIN ROCKS OVER 50mm IN DIAMETER FOR THE FIRST 300mm OVER CONDUIT.
- D. BACKFILL TO BE COMPACTED EVERY 300mm MINIMUM.
- E. FOR JOINT USE DETAILS REFER TO DWG. NO. 1U-ED-12M.
- F. ALL CONDUIT MUST BE CLEANED AND SWABBED, THEN CAPPED FOR PROTECTION.
- G. ALL CONDUIT SHALL HAVE A NYLON FISH LINE INSTALLED PRIOR TO CAPPING.
- H. MARKER TAPE (ITEM M1000) SHALL BE INSTALLED AS SHOWN.
- I. FOR TRANSFORMER PAD CONSTRUCTION REFER TO SECTION '6U'.
- J. FOR TRANSFORMER PAD LOCATION REFER TO DWG. NO. 7U-ED-10M.
- K. FOR CONDUIT DETAILS REFER TO DWG. NO. 2U-ED-21M.
- L. FOR CABLE TRAINING DETAILS REFER TO DWG. NO. 2U-ED-22M.
- M. GROUND TIE TO INTERCONNECT PADMOUNT TRANSFORMER GROUND(S) AND RISER POLE GROUND(S). REFER TO DWG. NO. 10U-ED-30M.
- N. ALL DIMENSIONS ARE IN MILLIMETRES UNLESS OTHERWISE SHOWN.

drawn *Craig N. Fairley*

designed *Paul M...*

approved *Ch...*

1Ø PAD-MOUNT TRANSFORMER
CONDUIT DETAILS

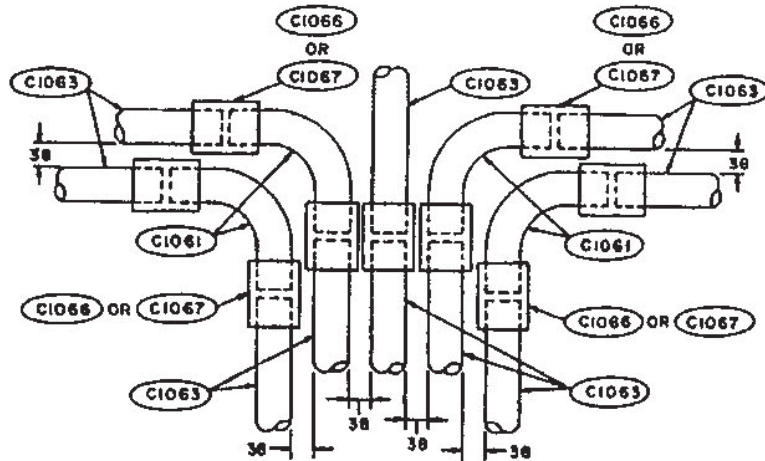

PRIMARY & SECONDARY CONDUITS
AT SERVICE TRENCH

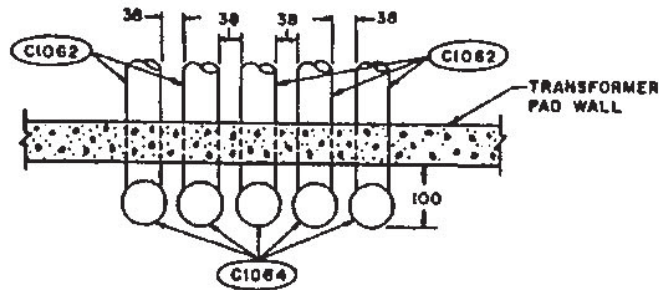

PRIMARY & SECONDARY CONDUITS
AT TRANSFORMER PAD

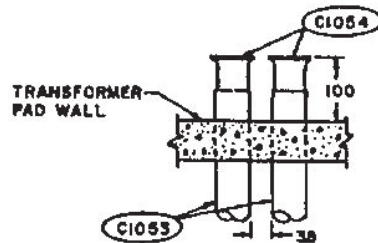

CUSTOMER SERVICE CONDUITS
AT TRANSFORMER PAD

NOTES:

- A. FOR TRENCHING DETAILS REFER TO DWG. NO. 2U-ED-20M.
- B. FOR DESCRIPTION OF HARDWARE ITEMS REFER TO SECTION '17U'.
- C. ALL DIMENSIONS ARE IN MILLIMETRES UNLESS OTHERWISE SHOWN.

drawn Greg H. Feary designed Laura Feary approved Matthew
Standards Committee

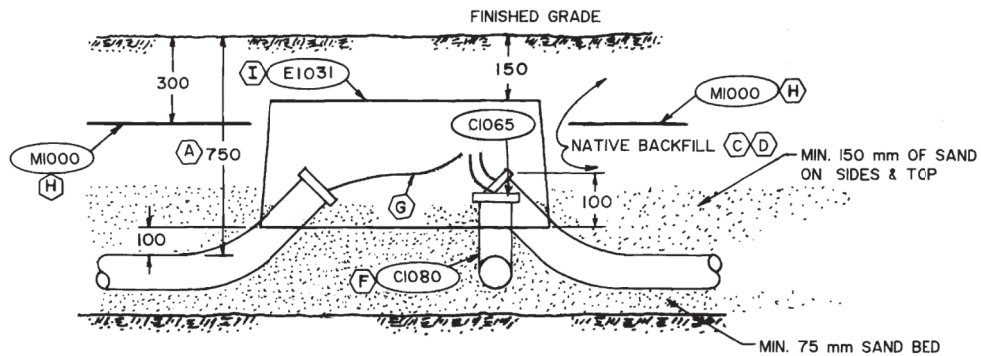
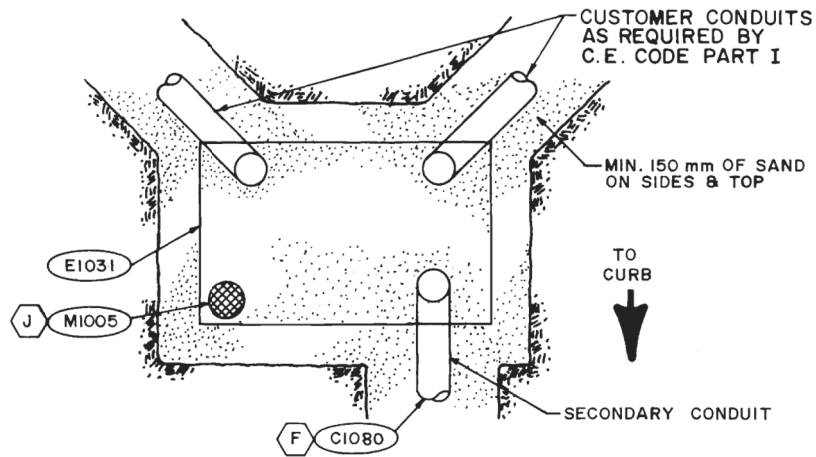

NOTES:

- A. REFER TO DWG. NO. IU-ED-44M FOR ROADWAY/DRIVEWAY REQUIREMENTS, MAY BE REDUCED TO 600 mm IF VOLTAGE DOES NOT EXCEED 750 VOLTS PHASE TO PHASE .
- B. CONDUIT TO BE BEDDED WITH SAND AS SHOWN .
- C. NATIVE BACKFILL MATERIAL SHALL NOT CONTAIN ROCKS OVER 50 mm IN DIAMETER FOR THE FIRST 300 mm OVER CONDUIT .
- D. BACKFILL TO BE COMPACTED EVERY 300mm MINIMUM .
- E. FOR JOINT USE DETAILS REFER TO DWG. NO. IU-ED-12M .
- F. ALL CONDUIT MUST BE CLEANED AND SWABBED, THEN CAPPED FOR PROTECTION .
- G. ALL CONDUIT SHALL HAVE A NYLON FISH LINE (ITEM N1000) INSTALLED PRIOR TO CAPPING .
- H. MARKER TAPE (ITEM M1000) SHALL BE INSTALLED AS SHOWN .
- I. URD BOX (ITEM E1031) SHALL COMPLETELY COVER CAPPED ENDS OF CONDUIT .
- J. LOCATOR (ITEM M1005) MUST BE INSTALLED INSIDE URD BOX .
- K. FOR URD BOX LOCATION REFER TO DWG. NO. 7U-ED-20M .
- L. FOR CABLE TRAINING DETAILS REFER TO DWG. NO. 2U-ED-31M .
- M. ALL DIMENSIONS ARE IN MILLIMETRES UNLESS OTHERWISE SHOWN .



DISTRIBUTION STANDARDS



**URD BOX AND CONDUIT DETAILS
SHOWING SECONDARY AND CUSTOMER'S CONDUITS
FOR SINGLE FAMILY HOMES**

DATE:	1988-08-15	REV DATE:	2018-10-09
DRAWN:	P. HUBLEY	STD NO:	2U-ED-30M
APPROVED:	<i>[Signature]</i>	SHT NO:	1 OF 1 (R2)

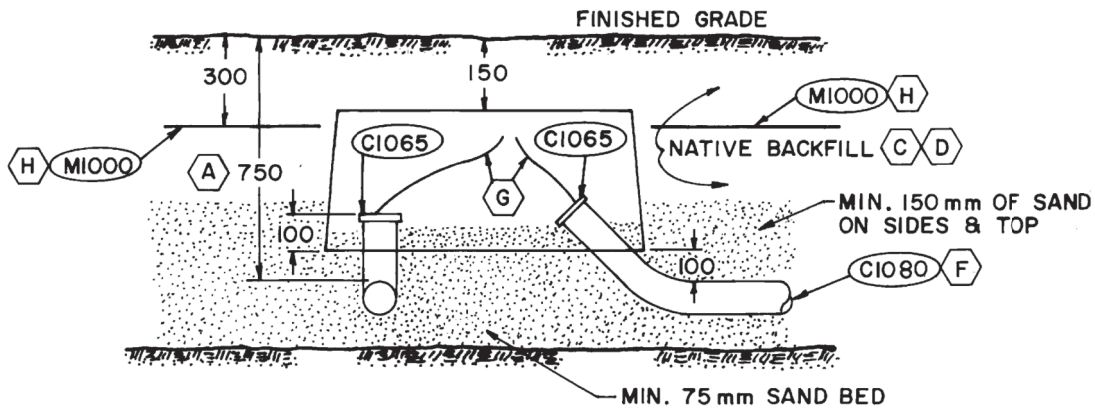
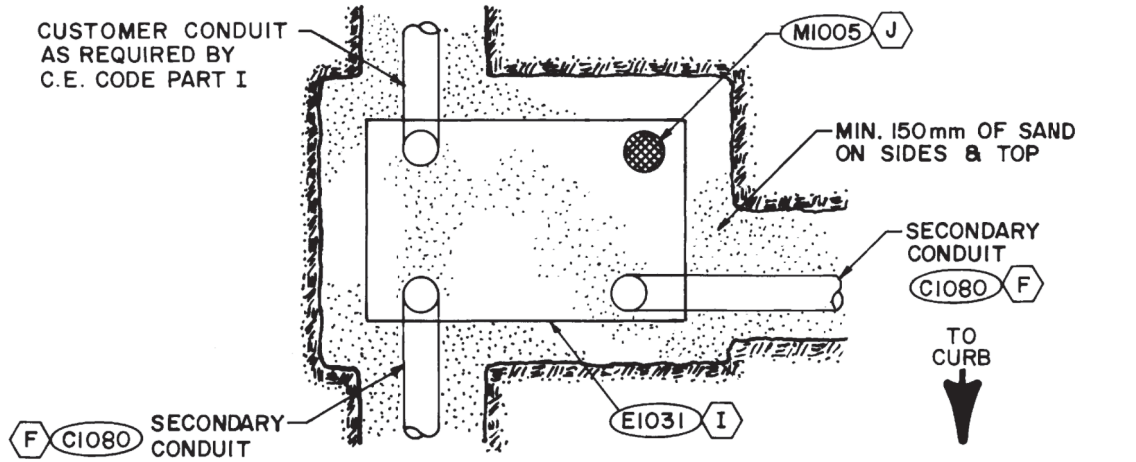

NOTES:

- A . REFER TO DWG. NO. IU-ED-44M FOR ROADWAY/DRIVEWAY REQUIREMENTS .
MAY BE REDUCED TO 600 mm IF VOLTAGE DOES NOT EXCEED 750 VOLTS PHASE TO PHASE .
- B . CONDUIT TO BE BEDDED WITH SAND AS SHOWN .
- C . NATIVE BACKFILL MATERIAL SHALL NOT CONTAIN ROCKS OVER 50 mm IN DIAMETER FOR THE FIRST 300 mm OVER CONDUIT .
- D . BACKFILL TO BE COMPACTED EVERY 300 mm MINIMUM .
- E . FOR JOINT USE DETAILS REFER TO DWG. NO. IU-ED-12M .
- F . ALL CONDUIT MUST BE CLEANED AND SWABBED , THEN CAPPED FOR PROTECTION .
- G . ALL CONDUIT SHALL HAVE A NYLON FISH LINE (ITEM N1000) INSTALLED PRIOR TO CAPPING .
- H . MARKER TAPE (ITEM M1000) SHALL BE INSTALLED AS SHOWN .
- I . URD BOX (ITEM E1031) SHALL COMPLETELY COVER CAPPED ENDS OF CONDUIT .
- J . LOCATOR (ITEM M1005) MUST BE INSTALLED INSIDE URD BOX .
- K . FOR URD BOX LOCATION REFER TO DWG. NO. 7U-ED-20M .
- L . FOR CABLE TRAINING DETAILS REFER TO DWG. NO. 2U-ED-37M .
- M . ALL DIMENSIONS ARE IN MILLIMETRES UNLESS OTHERWISE SHOWN .



DISTRIBUTION STANDARDS



**URD BOX AND CONDUIT DETAILS
SHOWING THROUGH SECONDARY
AND CUSTOMER SERVICE FOR CONDOMINIUMS**

DATE:	1988-08-15	REV DATE:	2018-10-09
DRAWN:	P. HUBLEY	STD NO:	2U-ED-36M
APPROVED:	<i>[Signature]</i>	SHT NO:	1 OF 1 (R2)

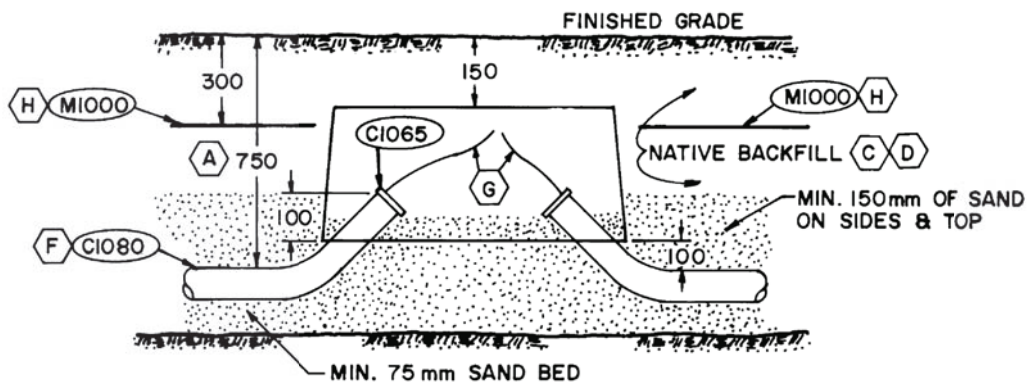
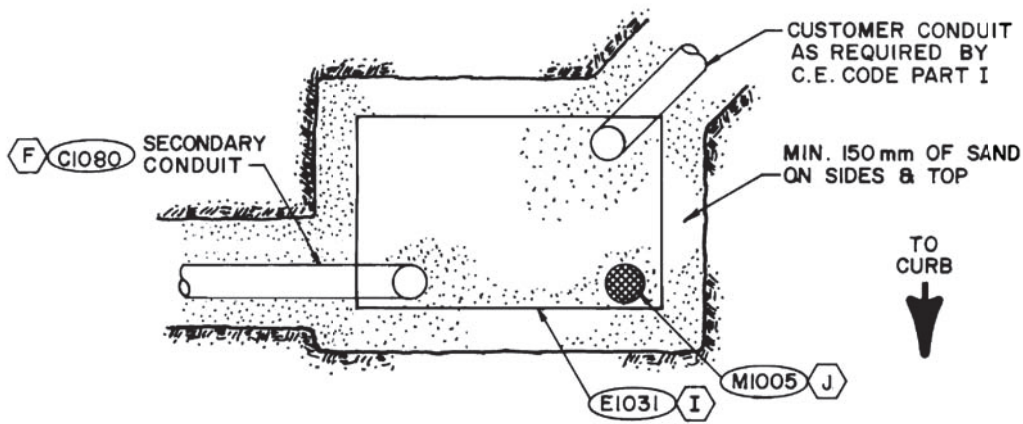

NOTES:

- A . REFER TO DWG. NO. IU-ED-44M FOR ROADWAY/DRIVEWAY REQUIREMENTS . MAY BE REDUCED TO 600 mm IF VOLTAGE DOES NOT EXCEED 750 VOLTS PHASE TO PHASE .
- B . CONDUIT TO BE BEDDED WITH SAND AS SHOWN .
- C . NATIVE BACKFILL MATERIAL SHALL NOT CONTAIN ROCKS OVER 50 mm IN DIAMETER FOR THE FIRST 300 mm OVER CONDUIT .
- D . BACKFILL TO BE COMPACTED EVERY 300 mm MINIMUM .
- E . FOR JOINT USE DETAILS REFER TO DWG. NO. IU-ED-12M .
- F . ALL CONDUIT MUST BE CLEANED AND SWABBED , THEN CAPPED FOR PROTECTION .
- G . ALL CONDUIT SHALL HAVE A NYLON FISH LINE (ITEM N1000) INSTALLED PRIOR TO CAPPING .
- H . MARKER TAPE (ITEM M1000) SHALL BE INSTALLED AS SHOWN .
- I . URD BOX (ITEM E1031) SHALL COMPLETELY COVER CAPPED ENDS OF CONDUIT .
- J . LOCATOR (ITEM M1005) MUST BE INSTALLED INSIDE URD BOX .
- K . FOR URD BOX LOCATION REFER TO DWG. NO. 7U-ED-20M .
- L . FOR CABLE TRAINING DETAILS REFER TO DWG. NO. 2U-ED-39M .
- M . ALL DIMENSIONS ARE IN MILLIMETRES UNLESS OTHERWISE SHOWN .



DISTRIBUTION STANDARDS



**URD BOX AND CONDUIT DETAILS
SHOWING SECONDARY AND
CUSTOMER SERVICE FOR CONDOMINIUMS**

DATE:	1988-08-15	REV DATE:	2018-10-09
DRAWN:	P. HUBLEY	STD NO:	2U-ED-38M
APPROVED:	<i>[Signature]</i>	SHT NO:	1 OF 1 (R2)

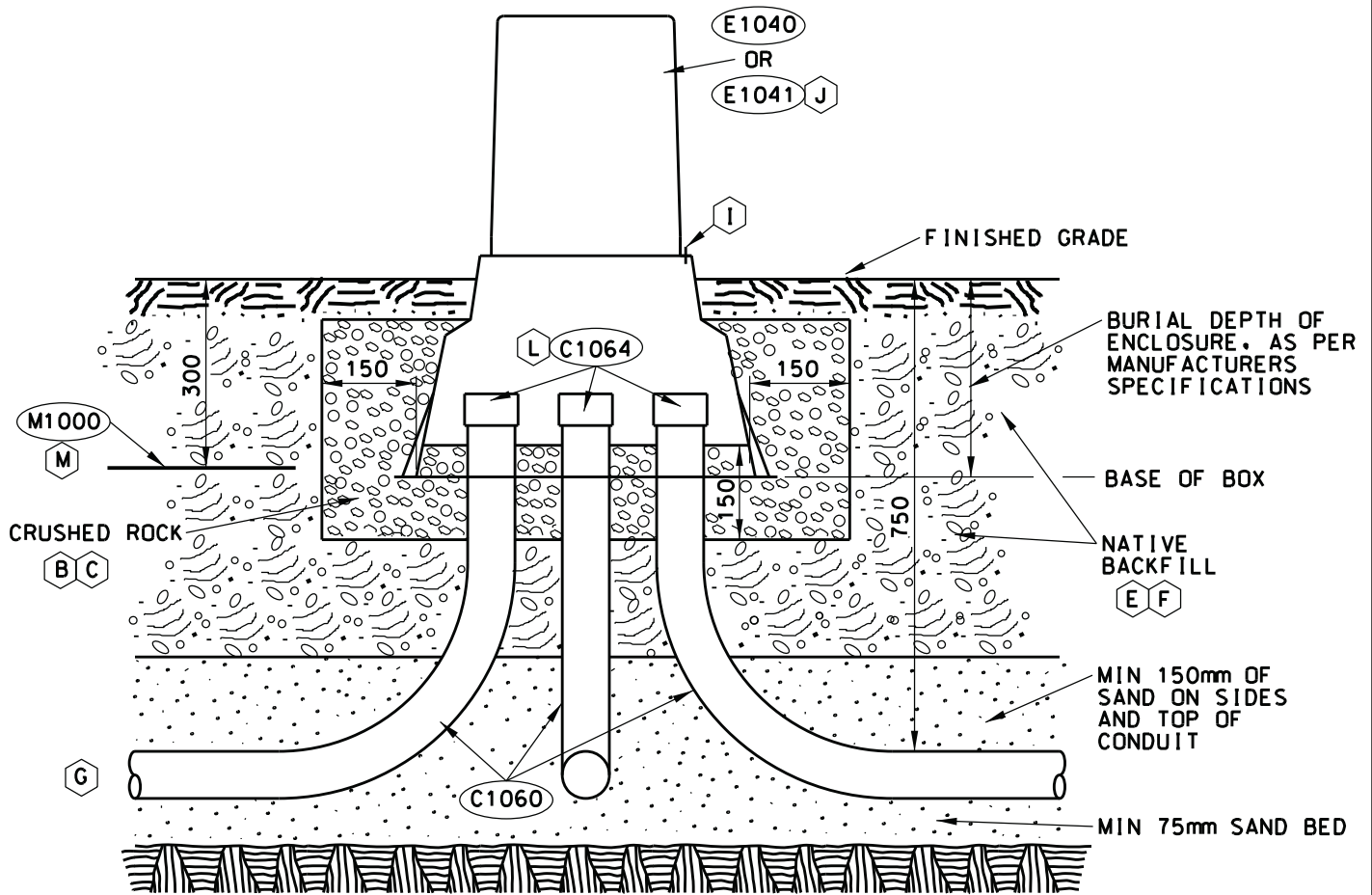

NOTES:

- A. LOCATIONS, SETBACKS AND PROTECTION MUST BE AS PER 7U-ED-10M OR 7U-ED-11M AS APPLICABLE.
- B. BASE OF CRUSHED ROCK MUST BE COMPACTED BEFORE SETTING THE BOX. CRUSHED ROCK TO BE 9.5 TO 19mm (3/8" TO 3/4").
- C. CARE TO BE TAKEN WHEN COMPACTING/BACKFILLING URD BASE SO NOT TO DISTORT SHAPE OF BASE (CAN CAUSE TOP OF URD TO FIT INCORRECTLY OR NOT AT ALL).
- D. PLACE 50mm OF STONE INSIDE THE BOX FIRST THEN FILL OUTSIDE.
- E. NATIVE BACKFILL MATERIAL SHALL NOT CONTAIN ROCKS OVER 50mm IN DIAMETER FOR THE FIRST 300mm OVER CONDUIT.
- F. BACKFILL TO BE COMPACTED EVERY 300mm MINIMUM.
- G. FOR JOINT USE DETAILS REFER TO DWG NO 1U-ED-12M.
- H. ALL SIDES OF URD BASE MUST BE COVERED (CRUSHED ROCK/ BACKFILLING). IN SUBDIVISIONS WITH DITCHES PROVISIONS MUST BE TAKEN TO ENSURE THIS (i.e. EASEMENT ON PRIVATE PROPERTY, CRIBBING).
- I. HEX NUT MUST BE INSTALLED.
- J. SMALLER SIZE ABOVE GRADE URD BOX E1041 MAY BE USED IF USED AS LAST BOX (DOES NOT FEED ANOTHER URD BOX) SMALL MOLDS WILL ALSO BE REQUIRED.
- K. CONDUIT MUST BE AT LEAST 25mm (1") ABOVE THE STONE.
- L. ALL CONDUIT SHALL HAVE A NYLON FISH LINE (ITEM N1000) INSTALLED PRIOR TO CAPPING.
- M. MARKER TAPE (ITEM M1000) SHALL BE INSTALLED AS SHOWN.

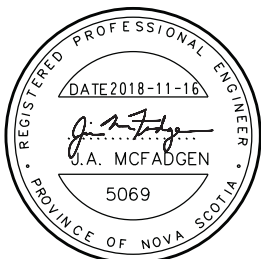

DISTRIBUTION STANDARDS



ABOVE GROUND URD BOX AND CONDUIT INSTALLATION DETAILS

DATE:	2013-10-28	REV DATE:	2018-11-07
DRAWN:	P. HUBLEY	STD NO:	2U-ED-54M
APPROVED:	<i>J.A. MCFADGEN</i>	SHT NO:	1 OF 1 (R2)

TX RATING (KVA)	VOLTAGE RATING OF TRANSFORMER (V)	
	600 Y / 347	208 Y / 120
150	4 - FIG 1	6 - FIG 2
300	4 - FIG 1	6 - FIG 2
500	6 - FIG 2	8 - FIG 3
750	6 - FIG 2	8 - FIG 3
1000	6 - FIG 2	8 - FIG 3
1500	8 - FIG 3	N/A
2000	8 - FIG 3	N/A
2500	8 - FIG 3	N/A
3000	8 - FIG 3	N/A

NUMBER OF ACCEPTABLE CABLE CONNECTIONS

FIG 1

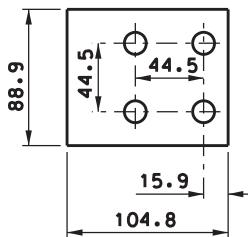

FIG 2

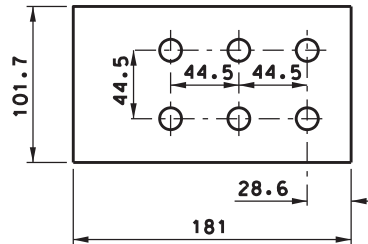
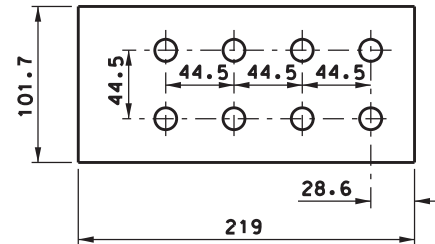

FIG 3



NOTES:

- A. ALL DIMENSIONS ARE IN MILLIMETRES
- B. TWO HOLE TERMINALS ARE TO BE USED.
- C. ALL HOLES ARE 14.3mm ± 0.8mm DIAMETER
- D. REFER TO 4U-11M AND 4U-12M FOR NSPI APPROVED SECONDARY TERMINALS.
- E. SECONDARY TERMINALS ARE NOT TO BE STACKED ON ONE SIDE OF THE LV BUSHING.

DISTRIBUTION STANDARDS



Paul Hubley
NSPI APPROVAL:

MAXIMUM NUMBER OF SECONDARY CABLES ON 3 PHASE PADMOUNTS

DATE:	2016-01-06	REV DATE:	2016-04-12
DRAWN:	PAUL HUBLEY	STD NO:	4U-7M
APPROVED:	<i>Paul Hubley</i>	SHT NO:	1 OF 1 (R1)

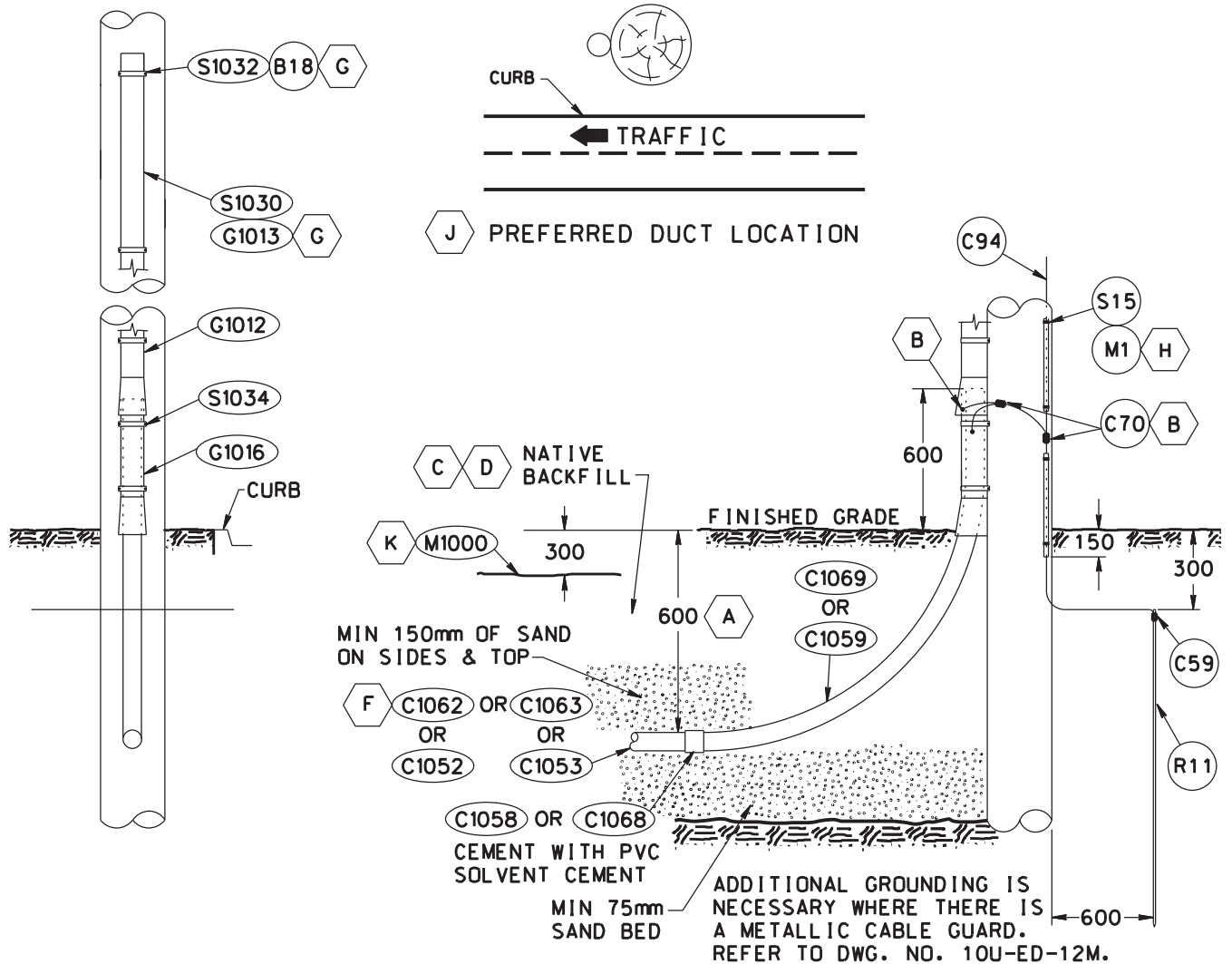

NOTES:

- A. MINIMUM COVER REQUIREMENTS FOR DIRECT BURIED CONDUIT IN VEHICULAR AREAS IS 1000mm.
- B. FOR BONDING OF CABLE GUARDS, REFER TO DWG. NO. 10U-ED-12M.
- C. NATIVE BACKFILL MATERIAL SHALL NOT CONTAIN ROCKS OVER 50mm IN DIAMETER FOR THE FIRST 300mm ABOVE CONDUIT.
- D. BACKFILL SHALL BE COMPACTED EVERY 300mm MINIMUM.
- E. FOR JOINT USE DETAILS, REFER TO DWG. NO. 1U-ED-25M.
- F. ALL CONDUIT MUST BE CLEANED, HAVE NYLON FISH LINE (ITEM N1000) INSTALLED, AND THEN CAPPED FOR PROTECTION.
- G. STRAP CABLE TO THE POLE EVERY 3000mm AND THE CABLE GUARD TO THE POLE EVERY 1200mm.
- H. STAPLE GROUND WIRE MOULDING TO THE POLE EVERY 600mm.
- I. CONDUIT RUNS SHALL BE CONSTRUCTED BY THE CUSTOMER OR HIS AGENT AND BE INSPECTED BY NSPI REPRESENTATIVES PRIOR TO BACKFILLING.
- J. THE CONDUIT SHALL NOT BE INSTALLED ON THE CURB OR TRAFFIC SIDE OF THE POLE.
- K. MARKER TAPE (ITEM M1000) SHALL BE INSTALLED ABOVE THE CONDUIT FOR ITS ENTIRE LENGTH, AS SHOWN.
- L. NOT APPLICABLE TO CUSTOMER OWNED SERVICE ENTRANCE.

(SAME AS OU-ED-20M)



DISTRIBUTION STANDARDS



**CONDUIT TERMINATION AT POLE FOR UNDERGROUND SERVICES
(URD SUPPLY, 750 VOLTS AND LESS)**

DATE:	2008-08-14	REV DATE:	2018-05-29
DRAWN:	M. HALASZ	STD NO:	5U-ED-20M
APPROVED:	J. A. MCFADGEN	SHT NO:	1 OF 1 (R3)

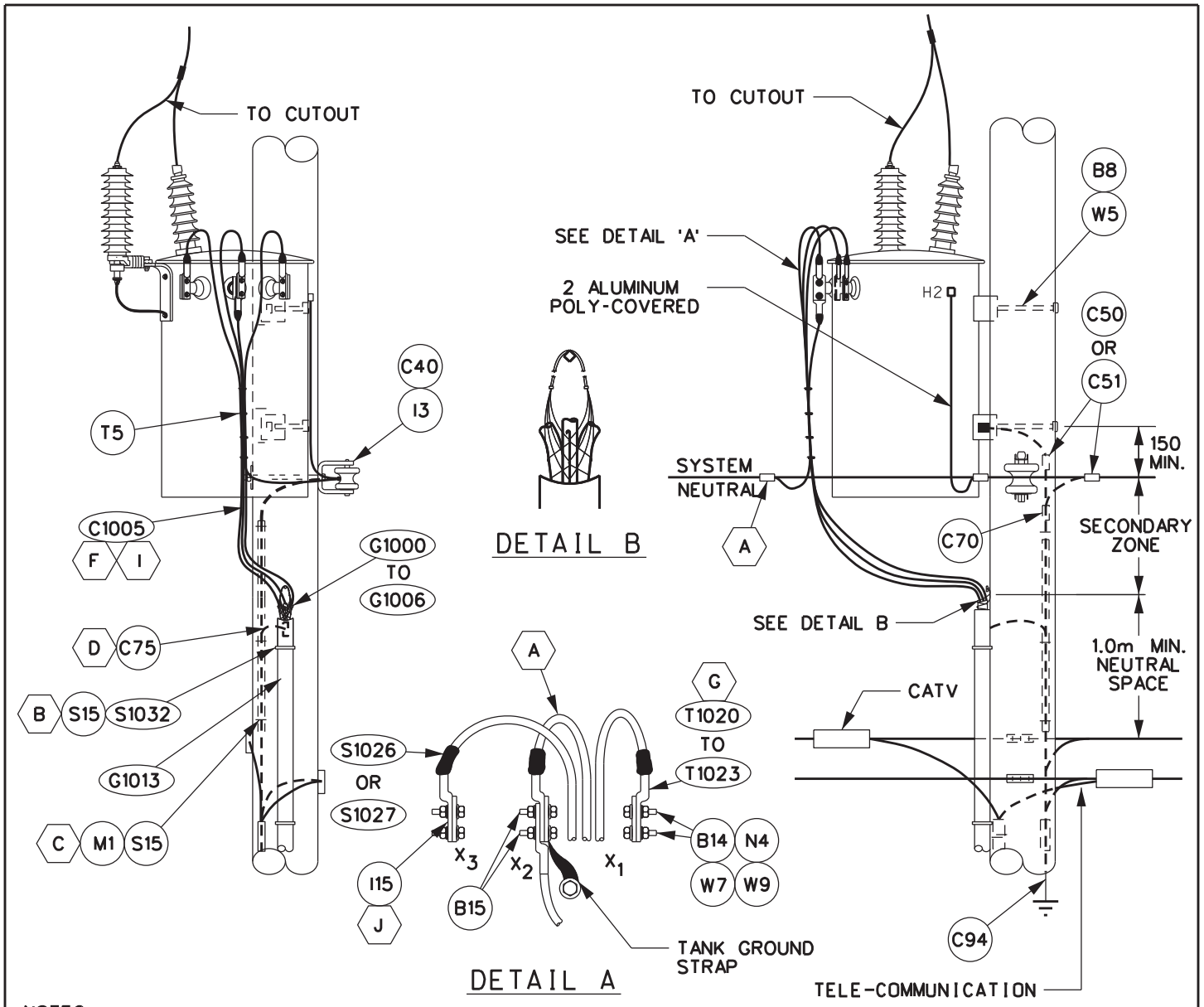

NOTES:

- A. MINIMUM #1/0 ALUMINUM POLY-COVERED SHALL BE USED FOR X2 BOND TO SYSTEM NEUTRAL.
- B. CABLE GUARD TO BE STRAPPED TO POLE EVERY 1200 mm.
- C. GROUND WIRE MOULDING TO BE STRAPPED TO POLE EVERY 600 mm.
- D. ALL CABLE GUARDS SHALL BE CONNECTED TOGETHER AND BONDED TO GROUND WIRE WITH A #2 AWG STRANDED COPPER WIRE. REFER TO DWG. G-ED-12M.
- E. FASTEN CABLES TO POLE WITH KELLEMS GRIP. SEE DETAIL B.
- F. FOR CABLE DATA REFER TO SECTION "3U".
- G. FOR TERMINAL INSTALLATION DETAILS REFER TO SECTION '4U' OF THE U/G STANDARDS MANUAL.
- H. FOR CONDUIT TERMINATION DETAILS REFER TO DWG. NO. OU-ED-20M.
- I. MINIMUM LENGTH OF SECONDARY CABLE FOR MAKING CONNECTIONS AND FORMING DRIP LOOP SHALL BE 1.5 m MEASURED FROM THE TOP OF CONDUIT.
- J. USE AN APPROVED INHIBITOR WHEN THE TRANSFORMER TERMINAL IS OF DISSIMILAR MATERIAL THAN THE CONDUCTOR TERMINAL.
- K. FOR URD BOX LOCATION REFER TO DWG. 7U-ED-21M.
- L. ALL DIMENSIONS ARE IN MILLIMETERS UNLESS OTHERWISE NOTED.

(SAME AS OU-ED-21M)



DISTRIBUTION STANDARDS



**OVERHEAD TRANSFORMER TERMINATION DETAILS
UNDERGROUND SERVICE DIRECTLY TO A URD BOX**

DATE:	1987-12-01	REV DATE:	2017-01-04
DRAWN:	M. HALASZ	STD NO:	5U-ED-21M
APPROVED:	J. A. MCFADGEN	SHT NO:	1 OF 1 (R1)

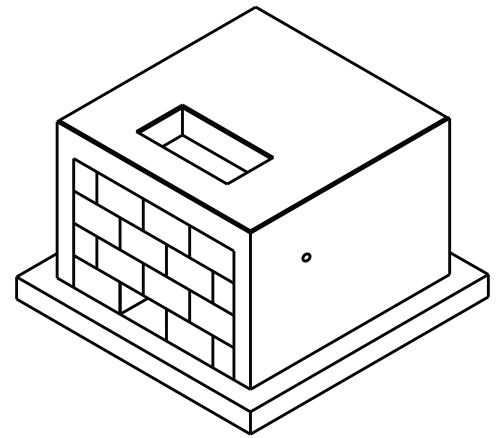
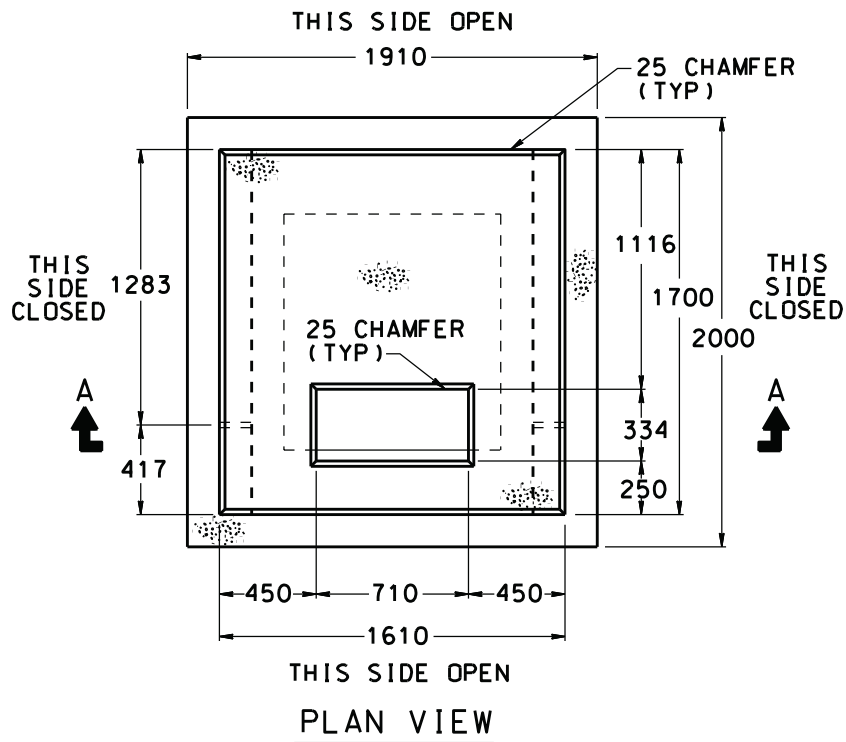

ISO VIEW

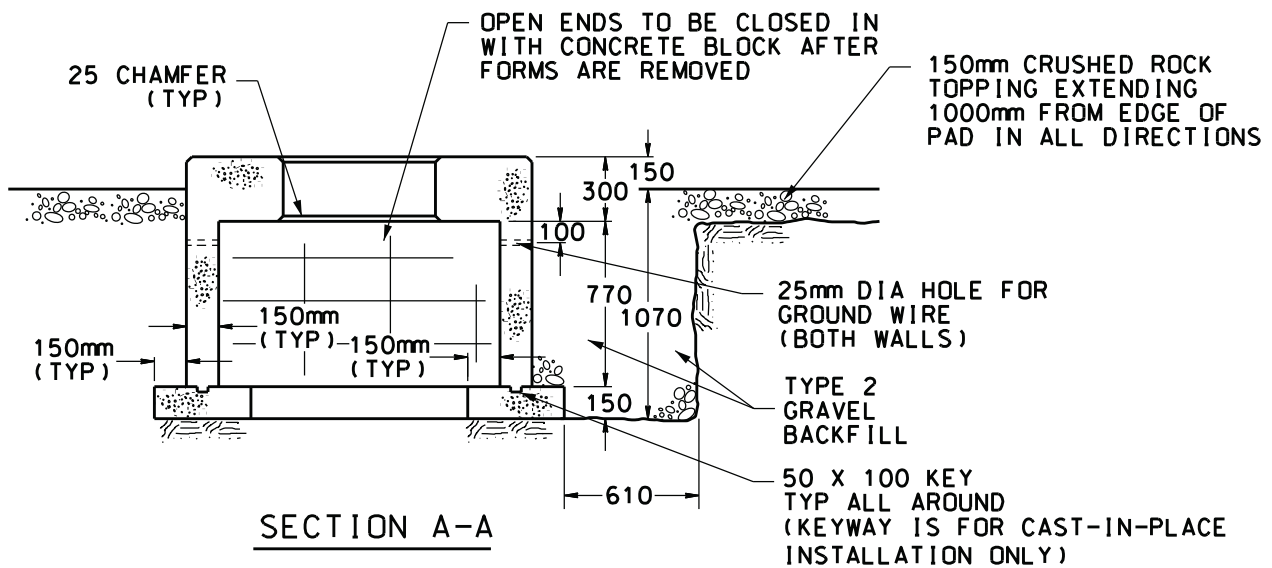

NOTES:

- A. CONCRETE - 30 MPa @ 28 DAYS.
- B. REFER TO DWG. NO. 6U-ED-11M FOR REINFORCING DETAILS .
- C. REFER TO DWG. NO. 6U-ED-12M FOR FIRE-RESISTING BARRIER IF REQUIRED.
- D. REFER TO DWG. NO. 10U-ED-30M FOR GROUNDING DETAILS.
- E. REFER TO DWG. NO. 2U-ED-20M FOR CONDUIT DETAILS.
- F. REFER TO DWG. NO. 2U-ED-22M FOR CABLE TRAINING DETAILS.
- G. LEAVE A MINIMUM OF 2000mm OF SECONDARY CABLE ABOVE THE PAD TO ALLOW FOR CABLE TRAINING AND TERMINATING ON THE TRANSFORMER.



DISTRIBUTION STANDARDS



**CONCRETE PAD FOR
SINGLE - PHASE PADMOUNT TRANSFORMER
50kVA - 167kVA**

DATE:	2008-09-15	REV DATE:	2017-02-03
DRAWN:	P. HUBLEY	STD NO:	6U-ED-10M
APPROVED:	<i>[Signature]</i>	SHT NO:	1 OF 1 (R2)

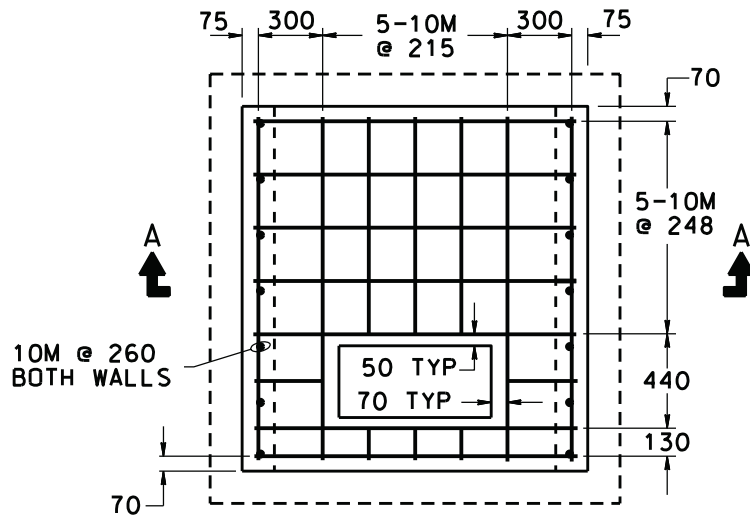

PLAN VIEW

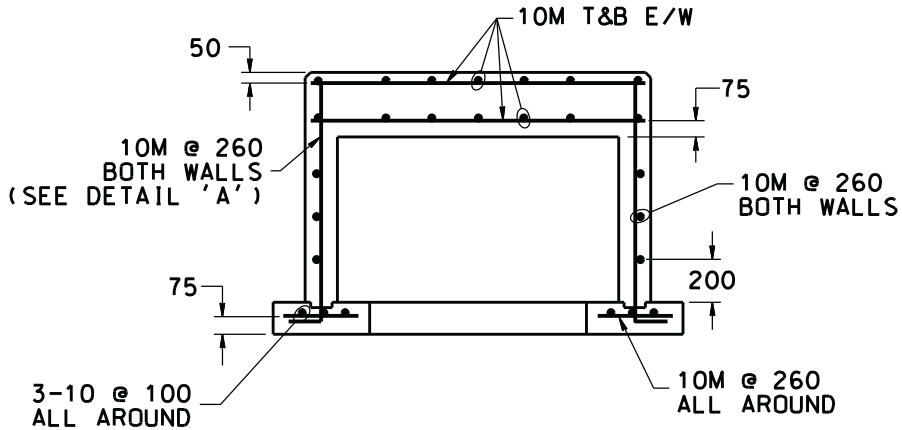
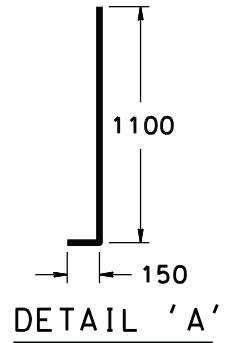

SECTION A-A

NOTES:
 A. REINFORCING - 400 MP_a YIELD.
 B. ALL DIMENSIONS ARE IN MILLIMETRES UNLESS OTHERWISE SHOWN.



DISTRIBUTION STANDARDS



**REINFORCING DETAILS FOR CONCRETE PAD
 SINGLE - PHASE PADMOUNT TRANSFORMER
 50kVA - 167kVA**

DATE:	2008-09-15	REV DATE:	2017-02-03
DRAWN:	P. HUBLEY	STD NO:	6U-ED-11M
APPROVED:	<i>[Signature]</i>	SHT NO:	1 OF 1 (R2)

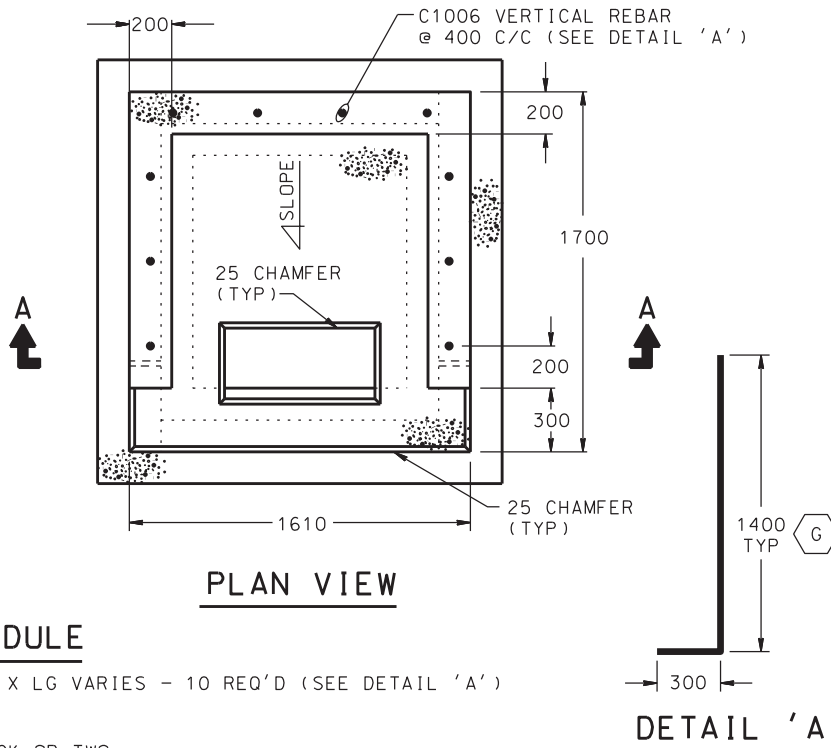

REBAR SCHEDULE

C1006 - #10M BAR X LG VARIES - 10 REQ'D (SEE DETAIL 'A')

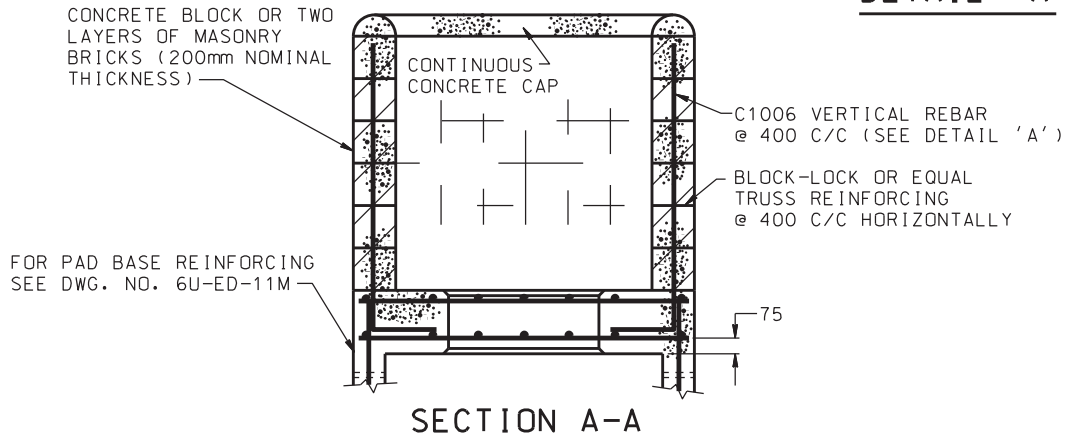

NOTES:

- A. REINFORCING - 400 MP_a YIELD.
- B. WHEN HOLLOW CONCRETE BLOCK IS USED, ALL OPENINGS IN THE BLOCK SHALL BE FILLED WITH MORTAR.
- C. IF MASONRY BRICK IS USED, PLACE VERTICAL REBAR (C1006) BETWEEN COLUMNS.
- D. SLOPE TRANSFORMER PAD TOWARDS OPEN END - 1:200.
- E. REFER TO DWG. NO. 6U-ED-13M FOR CONCRETE TOP IF REQUIRED.
- F. FOR TYPICAL CONSTRUCTION DETAILS REFER TO DWG. NO. 6U-ED-38M.
- G. LENGTH OF BAR WILL BE DETERMINED BY HEIGHT OF WALL, OR WALLS, REQUIRED TO SATISFY CANADIAN ELECTRICAL CODE REQUIREMENTS. FOR A BARRIER WITH A TOP, THE MINIMUM HEIGHT OF THE WALLS SHALL BE 2000mm AND THE BAR DIMENSION SHALL BE 2500mm TOTAL (2200mm ON THE LONG LEG AND 300mm ON THE SHORT LEG).



**DISTRIBUTION
UNDERGROUND
STANDARDS**



**FIRE-RESISTING BARRIER FOR
SINGLE-PHASE PADMOUNT TRANSFORMER
50 KVA - 167 KVA**

DATE: 2008-09-15	REV DATE: 2016-04-11
DRAWN: H. V. HUYNH	STD NO: 6U-ED-12M
APPROVED: <i>J. V. Tawil</i>	SHEET: 1 of 1 (R1)

**CONCRETE TOP OF FIRE-RESISTING BARRIER
SINGLE-PHASE PADMOUNT TRANSFORMER
50 KV·A - 167 KV·A**

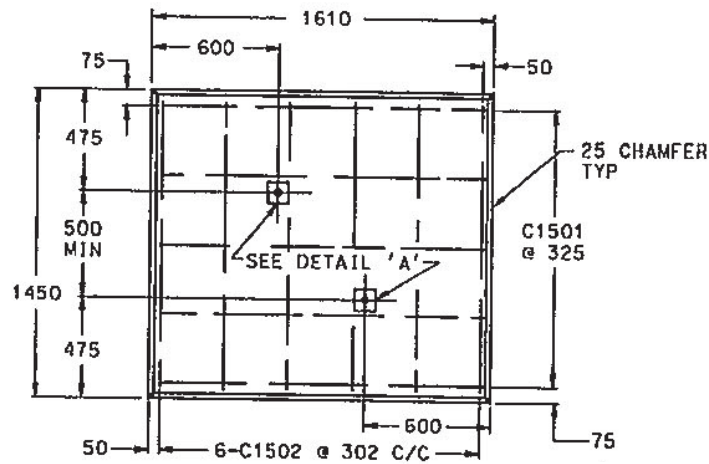

PLAN VIEW

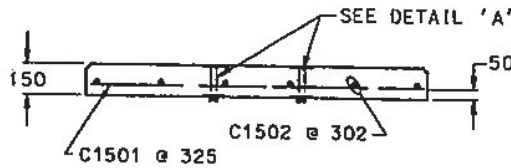

TYPICAL SECTION

REBAR SCHEDULE

- C1501 - #15M BAR X 1500mm LG - 5 REQ'D
- C1502 - #15M BAR X 1350mm LG - 6 REQ'D

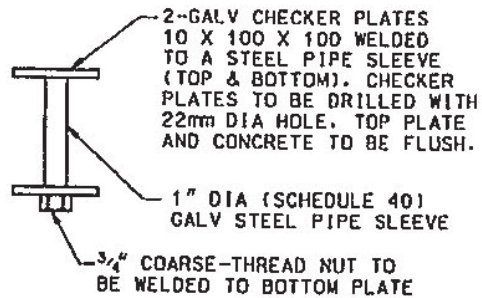

DETAIL 'A'

NOTES:

- A. CONCRETE - 30 MPa @ 28 DAYS.
- B. REINFORCING - 400 MPa YIELD.
- C. DO NOT LIFT PRECAST TOP UNTIL IT HAS BEEN ALLOWED TO CURE FOR A MINIMUM OF SEVEN DAYS.
- D. USE 3/4" EYE BOLTS (89kN STRENGTH AS PER CSA STD C83, ITEM B-24) FOR LIFTING CONCRETE TOP. THESE BOLTS ARE LISTED UNDER ITEM *B12 IN THE STANDARD HARDWARE AND MATERIAL LIST.
- E. ALL DIMENSIONS ARE IN MILLIMETRES UNLESS OTHERWISE SHOWN.

drawn *Craig N. Foy* designed *Al Bereng* approved *Construm*
 6STN FILE NAME: UCS-300,02316ED13M.DGN
 STANDARDS COMMITTEE

25 CHAMFER
(TYP)

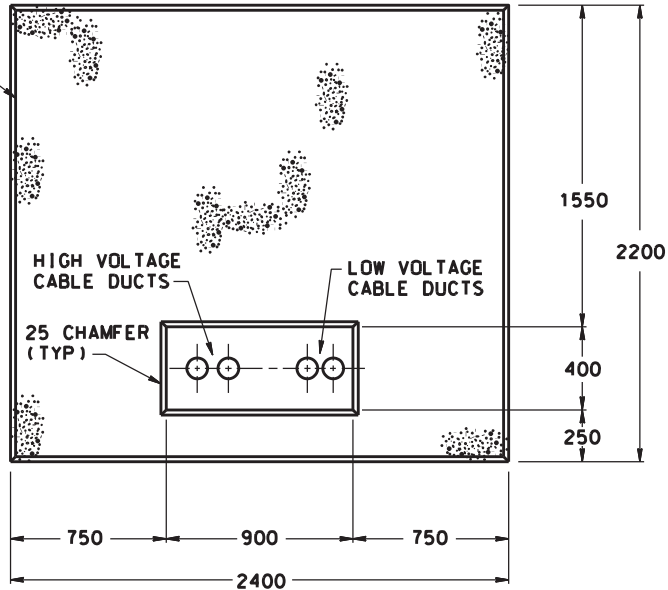

PLAN VIEW

* FOR OIL CONTAINMENT SLAB SEE 6U-ED-50M

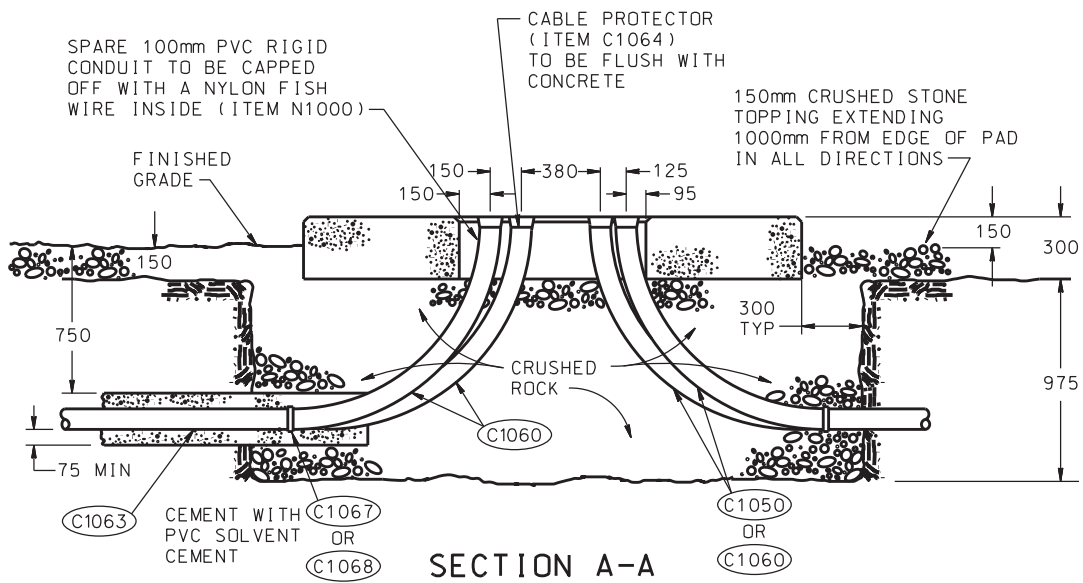

SECTION A-A

NOTES:

- A. CONCRETE - 30 MPa @ 28 DAYS.
- B. REFER TO DWG. NO. 6U-ED-21M FOR REINFORCING DETAILS .
- C. REFER TO DWG. NO. 6U-ED-22M FOR FIRE-RESISTING BARRIER IF REQUIRED.
- D. REFER TO DWG. NO. 10U-ED-30M FOR GROUNDING DETAILS.
- E. LEAVE A MINIMUM OF 2000mm OF SECONDARY CABLE ABOVE THE TOP OF THE PAD.



**DISTRIBUTION
UNDERGROUND
STANDARDS**



**CONCRETE PAD FOR
THREE-PHASE PADMOUNT TRANSFORMER
150 kVA - 500 kVA**

DATE: 2008-09-15	REV DATE: 2016-04-11
DRAWN: H. V. HUYNH	STD NO: 6U-ED-20M
APPROVED: <i>J. M. Tawil</i>	SHEET: 1 of 1 (R1)

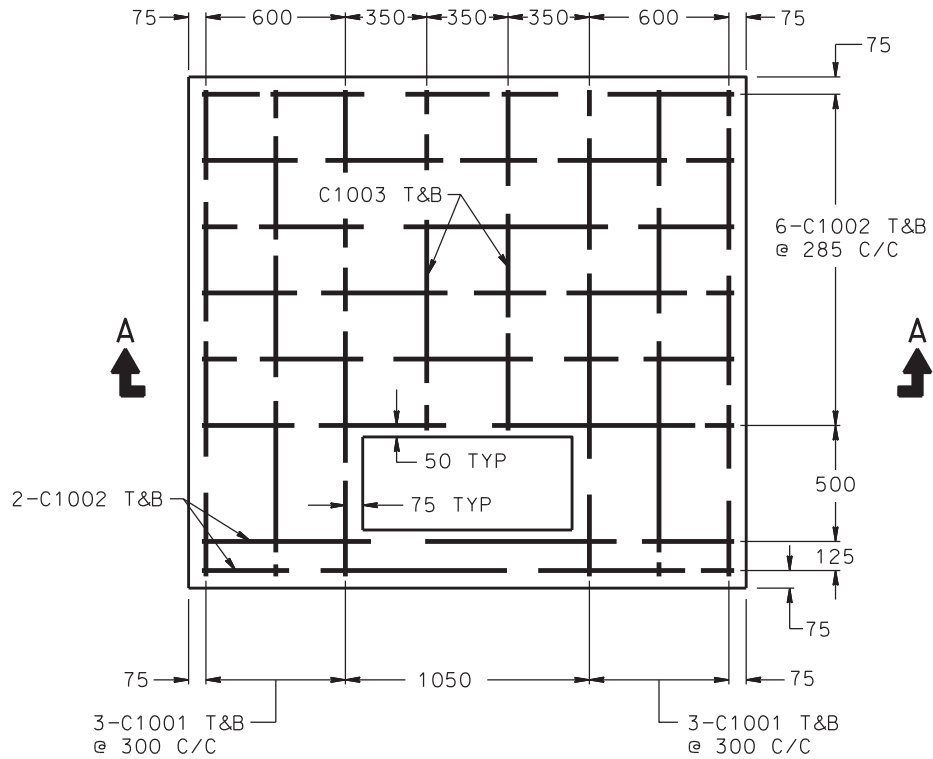

PLAN VIEW

REBAR SCHEDULE

- C1001 - #10M BAR X 2100mm LG - 12 REQ'D
- C1002 - #10M BAR X 2300mm LG - 16 REQ'D
- C1003 - #10M BAR X 1450mm LG - 4 REQ'D

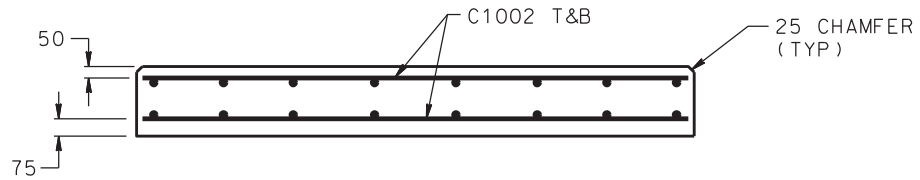

SECTION A-A

NOTES:

- A. REINFORCING - 400 MP_a YIELD.
- B. ALL DIMENSIONS ARE IN MILLIMETRES UNLESS OTHERWISE SHOWN.



**DISTRIBUTION
UNDERGROUND
STANDARDS**



**REINFORCING DETAILS FOR CONCRETE PAD
THREE-PHASE PADMOUNT TRANSFORMER
150 kVA - 500 kVA**

DATE: 2008-09-15	REV DATE: 2016-04-11
DRAWN: H. V. HUYNH	STD NO: 6U-ED-21M
APPROVED: <i>Justin Fadyen</i>	SHEET: 1 of 1 (R1)

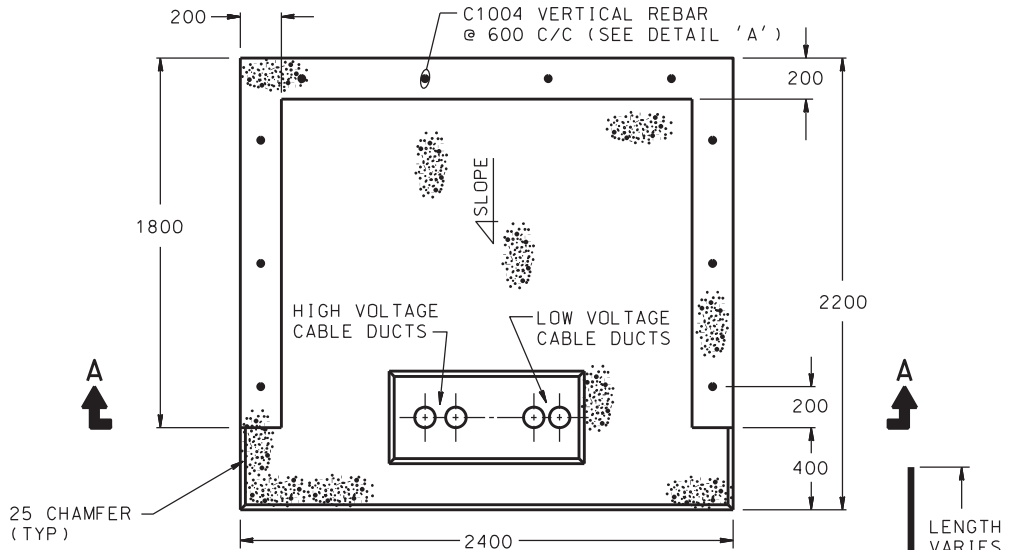

PLAN VIEW

REBAR SCHEDULE

C1004 - #10M BAR X LG VARIES - 10 REQ'D (SEE DETAIL 'A')

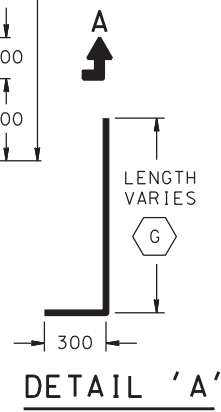

CONCRETE BLOCK OR TWO LAYERS OF MASONRY BRICKS (200mm NOMINAL THICKNESS)

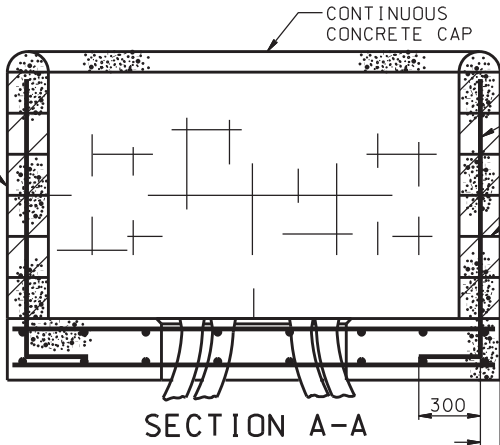

SECTION A-A

NOTES:

- A. REINFORCING - 400 MPa YIELD.
- B. WHEN HOLLOW CONCRETE BLOCK IS USED, ALL OPENINGS IN THE BLOCK SHALL BE FILLED WITH MORTAR.
- C. IF MASONRY BRICK IS USED, PLACE VERTICAL REBAR (C1004) BETWEEN COLUMNS.
- D. SLOPE TRANSFORMER PAD TOWARDS OPEN END - 1:200.
- E. FOR TYPICAL CONSTRUCTION DETAILS REFER TO DWG. NO. 6U-ED-38M.
- F. FOR CONCRETE TOP, IF REQUIRED FOR FIRE-RESISTING BARRIER, REFER TO DWG. NO. 6U-ED-23M.
- G. LENGTH OF BAR WILL BE DETERMINED BY HEIGHT OF WALL, OR WALLS, REQUIRED TO SATISFY CANADIAN ELECTRICAL CODE REQUIREMENTS. FOR A BARRIER WITH A TOP, THE MINIMUM HEIGHT OF THE WALLS SHALL BE 2000mm AND THE BAR DIMENSION SHALL BE 2500mm TOTAL (2200mm ON THE LONG LEG AND 300mm ON THE SHORT LEG).



DISTRIBUTION UNDERGROUND STANDARDS



FIRE-RESISTING BARRIER FOR THREE-PHASE PADMOUNT TRANSFORMER 150 kVA - 500 kVA

DATE: 2008-09-15	REV DATE: 2016-04-12
DRAWN: H. V. HUYNH	STD NO: 6U-ED-22M
APPROVED: <i>J. V. Huynh</i>	SHEET: 1 of 1 (R1)

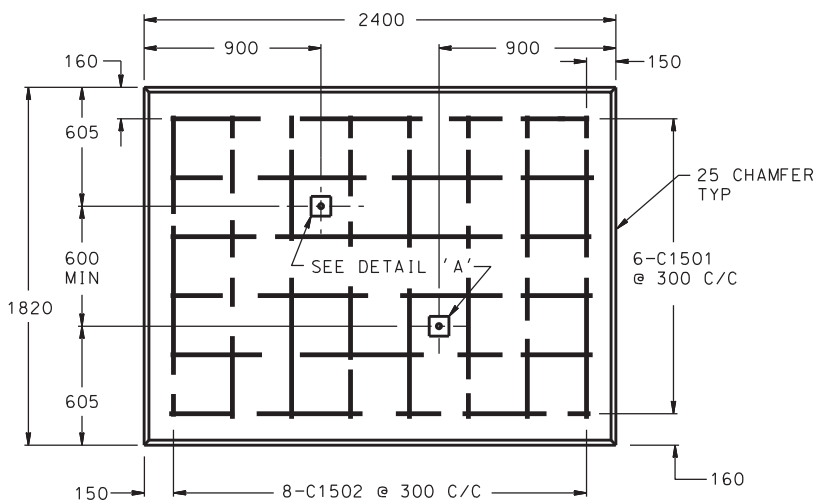

PLAN VIEW

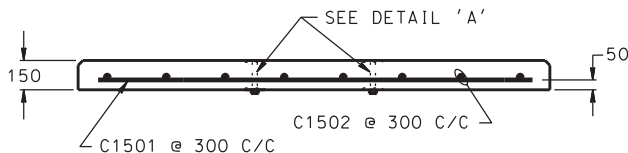

TYPICAL SECTION

REBAR SCHEDULE

- C1501 - #15M BAR X 2300mm LG - 6 REO'D
- C1502 - #15M BAR X 1600mm LG - 8 REO'D

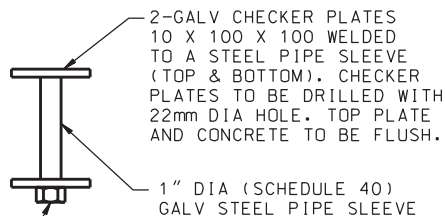

DETAIL 'A'

NOTES:

- A. CONCRETE - 30 MPa @ 28 DAYS.
- B. REINFORCING - 400 MPa YIELD.
- C. DO NOT LIFT PRECAST TOP UNTIL IT HAS BEEN ALLOWED TO CURE FOR A MINIMUM OF SEVEN DAYS.
- D. USE 3/4" EYE-BOLTS (89 kN STRENGTH AS PER CSA STD C83, ITEM B-24) FOR LIFTING CONCRETE TOP. THESE BOLTS ARE LISTED UNDER ITEM #B12 IN THE STANDARD HARDWARE AND MATERIAL LIST.
- E. ALL DIMENSIONS ARE IN MILLIMETRES UNLESS OTHERWISE SHOWN.



**DISTRIBUTION
UNDERGROUND
STANDARDS**



**CONCRETE TOP OF FIRE-RESISTING BARRIER
THREE-PHASE PASMOUNT TRANSFORMER
150 KVA - 500 KVA**

DATE: 2008-09-15	REV DATE: 2016-04-12
DRAWN: H. V. HUYNH	STD NO: 6U-ED-23M
APPROVED: <i>Justin Fudge</i>	SHEET: 1 of 1 (R1)

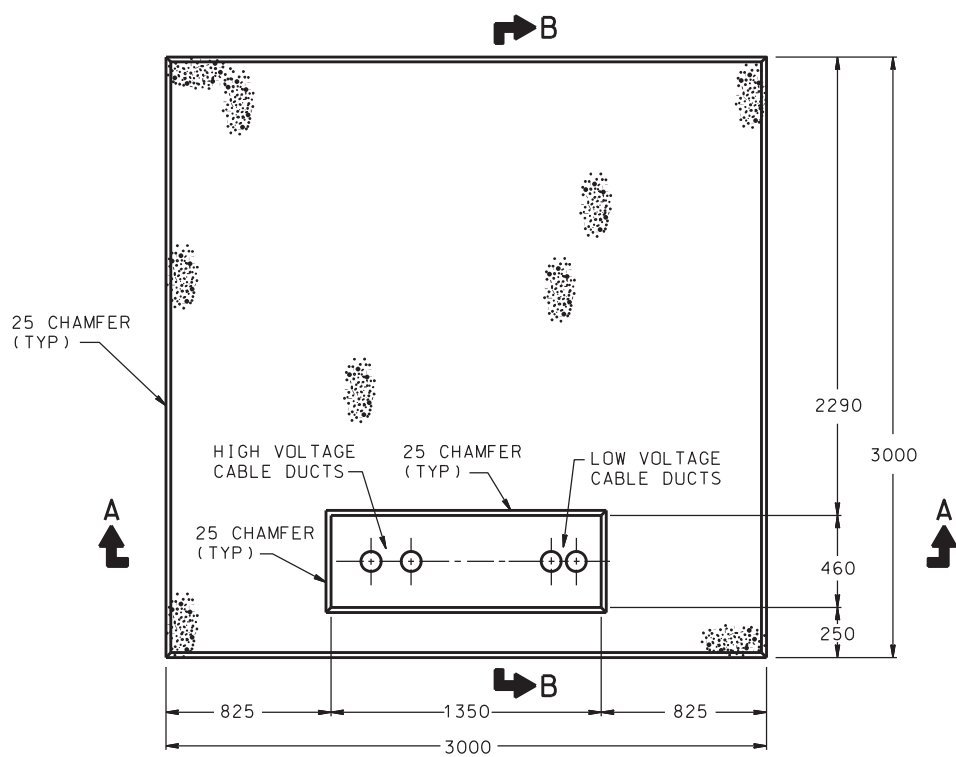

PLAN VIEW

* FOR OIL CONTAINMENT SLAB SEE 6U-ED-51M

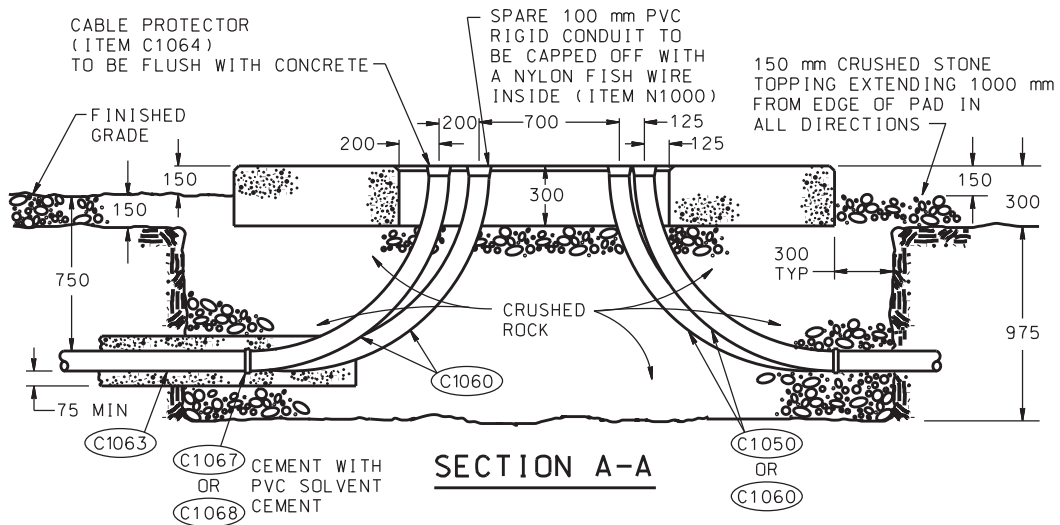

SECTION A-A

NOTES:

- A. CONCRETE - 30 MPa @ 28 DAYS.
- B. REFER TO DWG. NO. 6U-ED-25M FOR REINFORCING DETAILS.
- C. REFER TO DWG. NO. 10U-ED-30M FOR GROUNDING DETAILS.
- D. LEAVE A MINIMUM OF 2000 mm OF SECONDARY CABLE ABOVE TOP OF PAD.
- E. WHEN THE SECONDARY CABLES ARE LARGER THAN #750 kcmil THE 'DEEP-WELL' TRANSFORMER PAD IS REQUIRED. REFER TO DWG. NO. 6U-ED-26M FOR MODIFIED TRANSFORMER PAD CONSTRUCTION DETAILS.



**DISTRIBUTION
UNDERGROUND
STANDARDS**



**CONCRETE PAD FOR
THREE-PHASE PADMOUNT TRANSFORMER
750 KVA - 2500 KVA (STANDARD VERSION)**

DATE: 2008-08-14	REV DATE: 2016-04-12
DRAWN: H. V. HUYNH	STD NO: 6U-ED-24M
APPROVED: <i>Justin Fudge</i>	SHEET: 1 of 1 (R1)

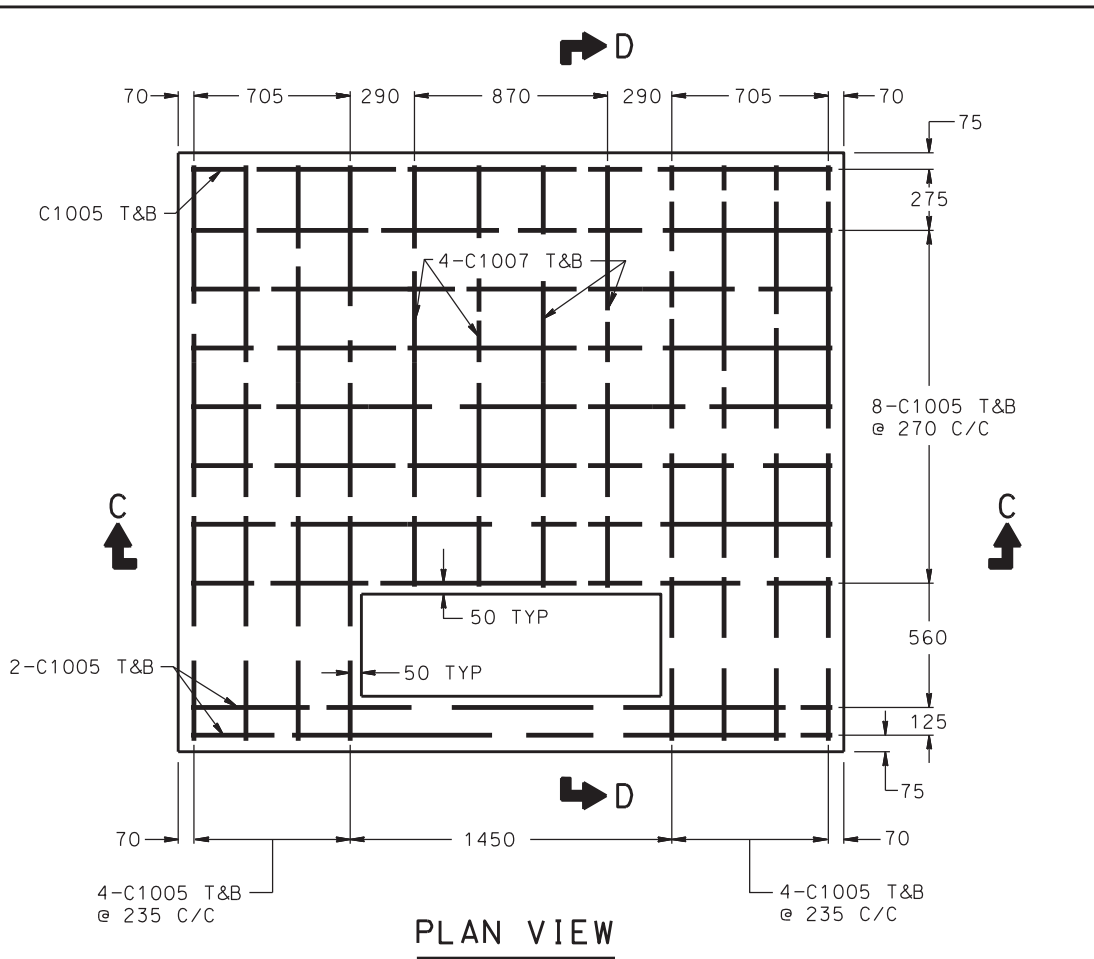

REBAR SCHEDULE

C1005 - #10M BAR X 2900mm LG - 38 REQ'D
 C1007 - #10M BAR X 2190mm LG - 8 REQ'D

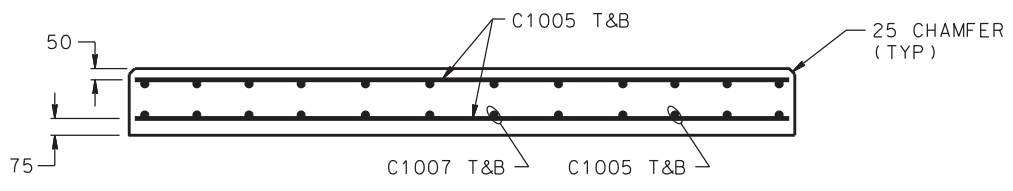

NOTES:

- A. REINFORCING - 400 MPa YIELD.
- B. WHEN THE SECONDARY CABLES ARE LARGER THAN #750 kcmil THE 'DEEP-WELL' TRANSFORMER PAD IS REQUIRED. REFER TO DWG. NO. 6U-ED-26M FOR MODIFIED CONSTRUCTION AND PAD REINFORCING DETAILS.

	DISTRIBUTION UNDERGROUND STANDARDS	
	REINFORCING DETAILS FOR CONCRETE PAD THREE-PHASE PADMOUNT TRANSFORMER 750 kVA - 2500 kVA (STANDARD VERSION)	
	DATE: 2008-09-15	REV DATE: 2016-04-12
	DRAWN: H. V. HUYNH	STD NO: 6U-ED-25M
APPROVED: <i>[Signature]</i>	SHEET: 1 of 1 (R1)	

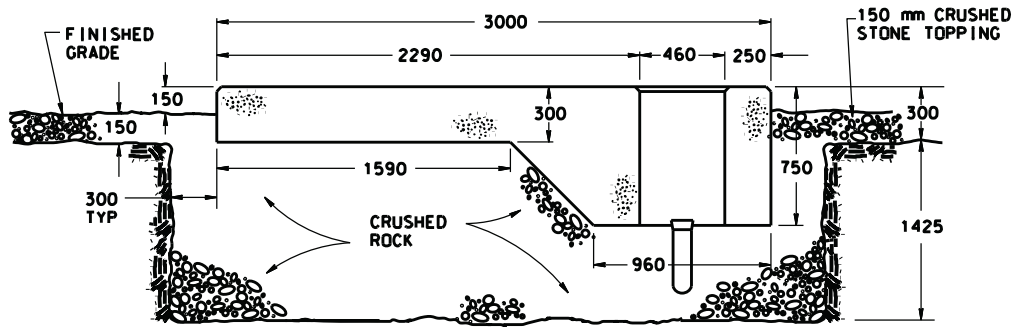

SECTION B-B

(DWG. NO. 6U-ED-24M)

REFER TO DWG. NO. 6U-ED-25M FOR REINFORCING DETAILS AND REBAR SCHEDULE FOR UPPER PART OF PAD

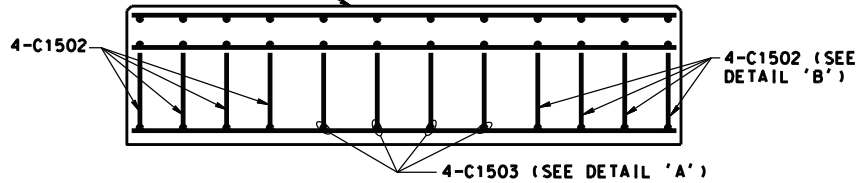

SECTION C-C

(DWG. NO. 6U-ED-25M)

REFER TO DWG. NO. 6U-ED-25M FOR REINFORCING DETAILS AND REBAR SCHEDULE FOR UPPER PART OF PAD

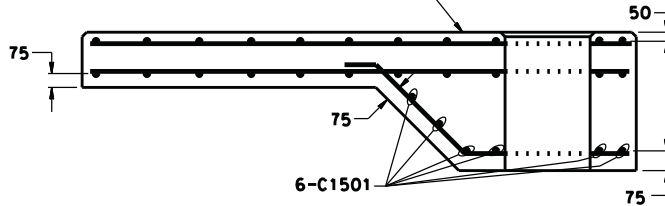

SECTION D-D

(DWG. NO. 6U-ED-25M)

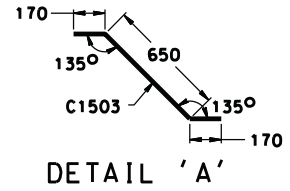

DETAIL 'A'

REBAR SCHEDULE

- C1501 - #15M BAR X 2900 mm LG - 6 REQ'D
- C1502 - #15M BAR X 1700 mm LG - 8 REQ'D
- C1503 - #15M BAR X 990 mm LG - 4 REQ'D

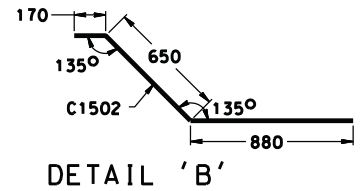

DETAIL 'B'

NOTES:

- A. REINFORCING - 350 MPa YIELD.
- B. TRANSFORMER PAD CONSTRUCTION TO BE AS SHOWN ONLY WHEN THE SECONDARY CABLES ARE LARGER THAN #750 kcmil.
- C. LEAVE A MINIMUM OF 2000 mm OF SECONDARY CABLE ABOVE SLAB.



DISTRIBUTION STANDARDS



**CONCRETE PAD FOR THREE-PHASE PADMOUNT TRANSFORMER
750KVA - 2500KVA
(DEEP-WELL DESIGN)**

DATE:	2008-08-14	REV DATE:	2017-02-15
DRAWN:	H. V. HUYNH	STD NO:	6U-ED-26M
APPROVED:	<i>[Signature]</i>	SHT NO:	1 OF 1 (R1)

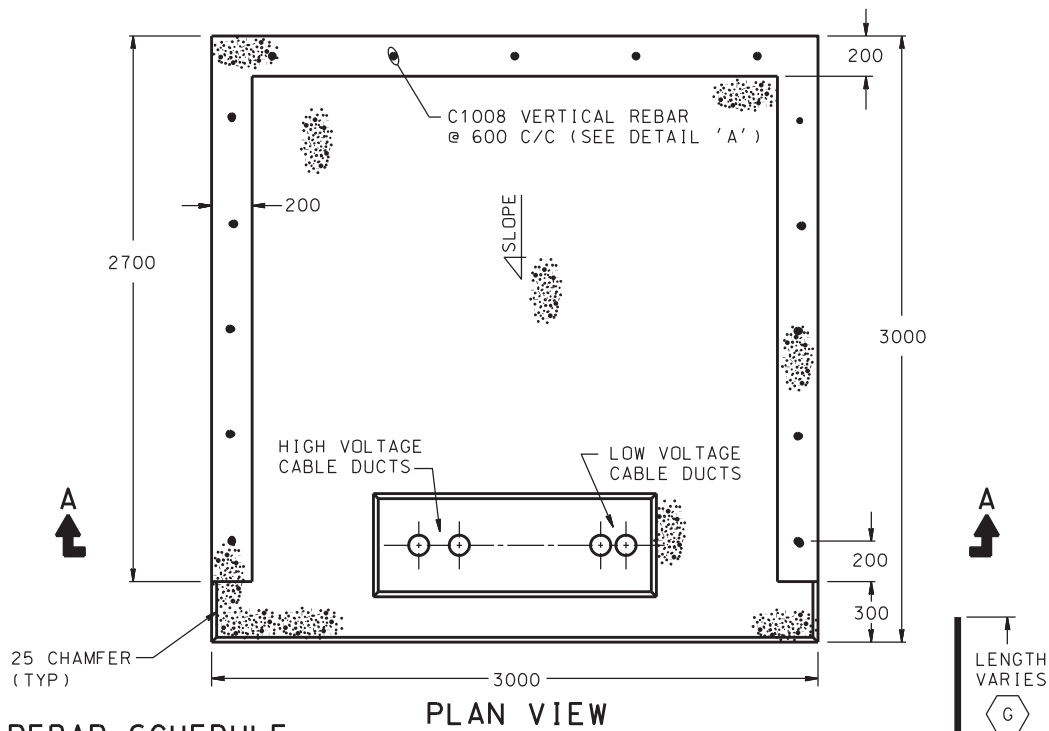

REBAR SCHEDULE

C1008 - #10M BAR X LG VARIES - 15 REQ'D (SEE DETAIL 'A')

CONCRETE BLOCK OR TWO LAYERS OF MASONRY BRICKS (200 mm NOMINAL THICKNESS)

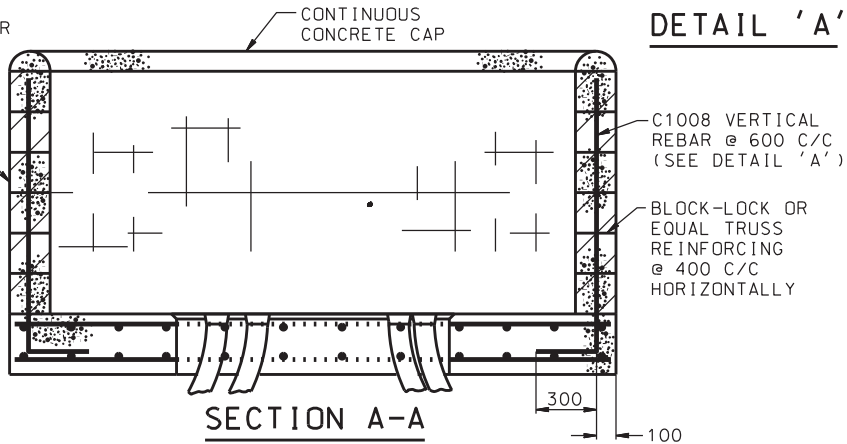

NOTES:

- A. REINFORCING - 400 MP_a YIELD.
- B. WHEN HOLLOW CONCRETE BLOCK IS USED, ALL OPENINGS IN THE BLOCK SHALL BE FILLED WITH MORTAR.
- C. IF MASONRY BRICK IS USED, PLACE VERTICAL REBAR (C1008) BETWEEN COLUMNS.
- D. SLOPE TRANSFORMER PAD TOWARDS OPEN END - 1:200.
- E. FOR TYPICAL CONSTRUCTION DETAILS REFER TO DWG. NO. 6U-ED-38M.
- F. FOR CONCRETE TOP, IF REQUIRED FOR FIRE-RESISTING BARRIER, REFER TO DWG. NO. 6U-ED-29M.
- G. LENGTH OF BAR WILL BE DETERMINED BY HEIGHT OF WALL, OR WALLS, REQUIRED TO SATISFY CANADIAN ELECTRICAL CODE REQUIREMENTS. FOR A BARRIER WITH A TOP, THE MINIMUM HEIGHT OF THE WALLS SHALL BE 2400 mm AND THE BAR DIMENSION SHALL BE 2900 mm TOTAL (2600 mm ON THE LONG LEG AND 300 mm ON THE SHORT LEG).



DISTRIBUTION UNDERGROUND STANDARDS



FIRE-RESISTING BARRIER FOR THREE-PHASE PADMOUNT TRANSFORMER 750 kVA - 2500 kVA

DATE: 2008-08-14	REV DATE: 2016-04-12
DRAWN: H. V. HUYNH	STD NO: 6U-ED-28M
APPROVED: <i>Justin Fadya</i>	SHEET: 1 of 1 (R1)

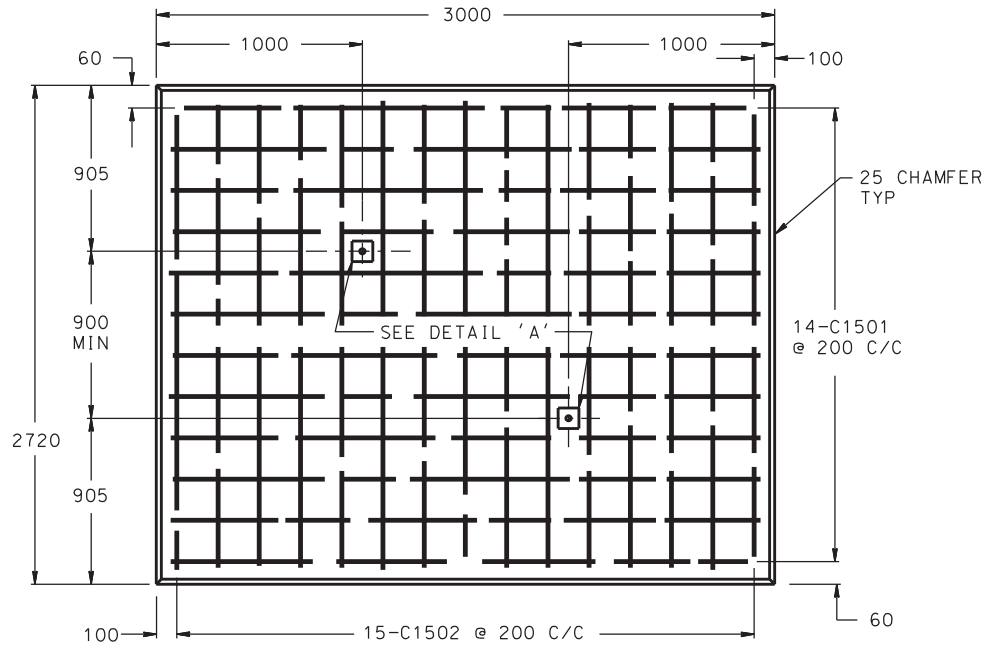

PLAN VIEW

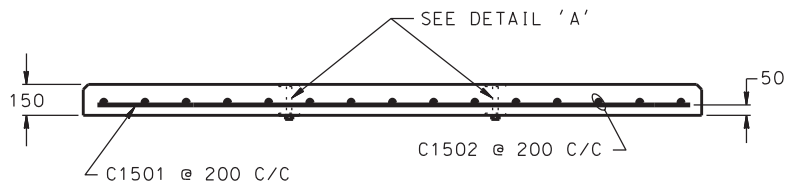

TYPICAL SECTION

REBAR SCHEDULE

- C1501 - #15M BAR X 2800 mm LG - 14 REQ'D
- C1502 - #15M BAR X 2500 mm LG - 15 REQ'D

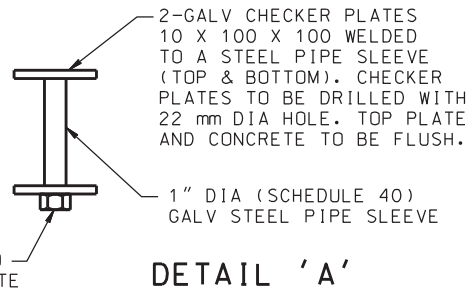

DETAIL 'A'

NOTES:

- A. CONCRETE - 30 MPa @ 28 DAYS.
- B. REINFORCING - 400 MPa YIELD.
- C. DO NOT LIFT PRECAST TOP UNTIL IT HAS BEEN ALLOWED TO CURE FOR A MINIMUM OF SEVEN DAYS.
- D. USE 3/4" EYE-BOLTS (89kN STRENGTH AS PER CSA STD C83, ITEM B-24) FOR LIFTING CONCRETE TOP. THESE BOLTS ARE LISTED UNDER ITEM #B12 IN THE STANDARD HARDWARE AND MATERIAL LIST.



**DISTRIBUTION
UNDERGROUND
STANDARDS**



**REINFORCING DETAILS FOR CONCRETE TOP
OF FIRE-RESISTING BARRIER THREE-PHASE
PADMOUNT TRANSFORMER
750 KVA - 2500 KVA**

DATE: 2006-05-30	REV DATE: 2016-04-12
DRAWN: H. V. HUYNH	STD NO: 6U-ED-29M
APPROVED: <i>[Signature]</i>	SHEET: 1 of 1 (R1)

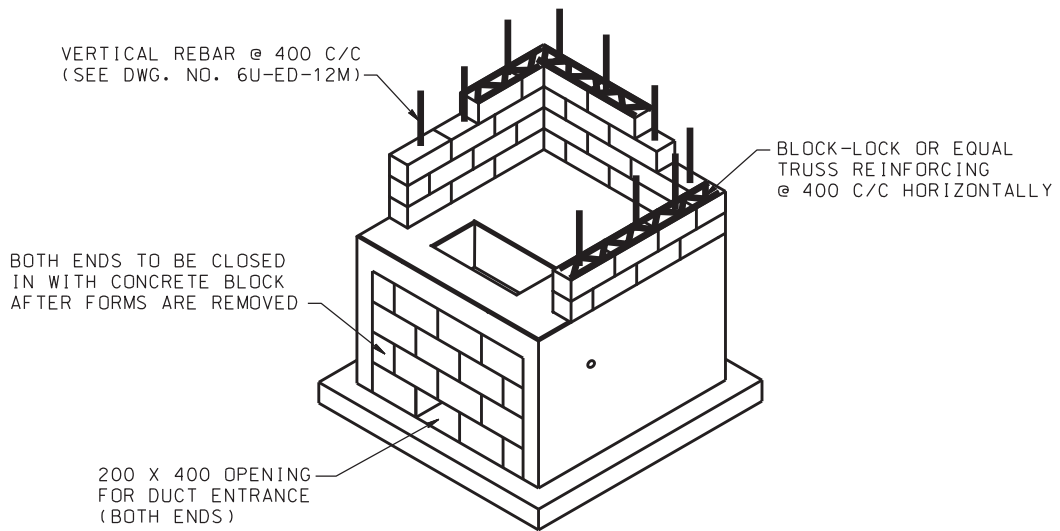

SINGLE-PHASE PAD CONSTRUCTION

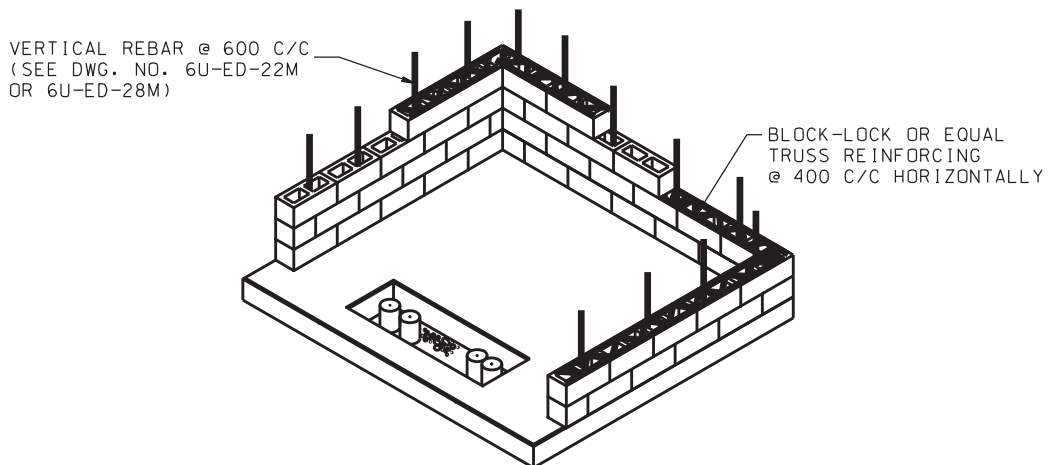

THREE-PHASE PAD CONSTRUCTION

NOTES:

A. ALL DIMENSIONS ARE IN MILLIMETRES UNLESS OTHERWISE SHOWN.



DISTRIBUTION UNDERGROUND STANDARDS



TYPICAL CONSTRUCTION DETAILS OF FIRE-RESISTING BARRIERS FOR PADMOUNT TRANSFORMERS

DATE: 2008-09-15	REV DATE: 2016-04-12
DRAWN: H. V. HUYNH	STD NO: 6U-ED-38M
APPROVED: <i>Justin Fadya</i>	SHEET: 1 of 1 (R1)

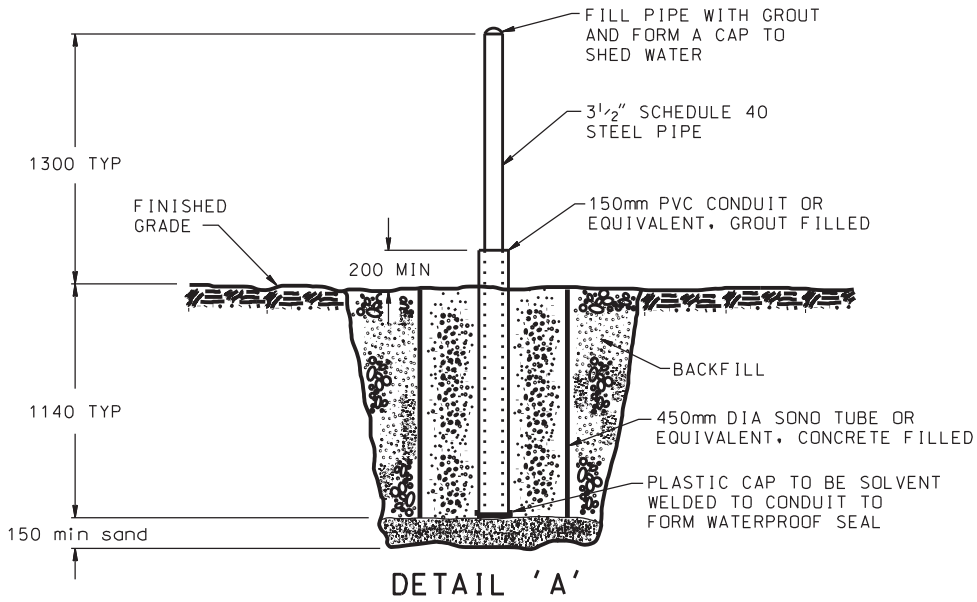
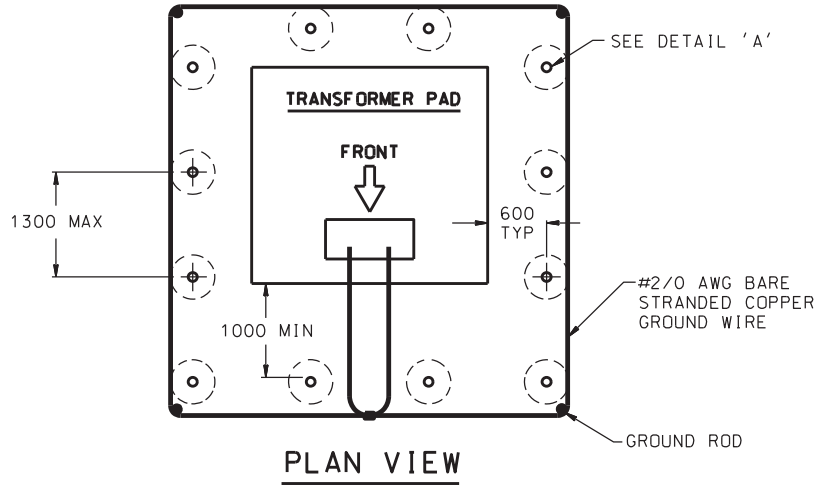

NOTES:

- A. THE PVC CONDUIT, OR EQUIVALENT, MUST BE INSTALLED TO INSULATE THE STEEL PIPE AND THUS PREVENT TRANSFER OF DANGEROUS TOUCH POTENTIAL IN THE EVENT OF A FAULT.
- B. STAND-OFFS SHALL BE PLACED SO AS TO NOT OBSTRUCT ANY DOORS OR RESTRICT THE SAFE OPERATION OF THE UNIT. IN ALL CASES, THEY SHALL BE A MINIMUM OF 1000mm FROM THE EDGE OF THE PAD ALONG THE FRONT SIDE.
- C. THE MAXIMUM ALLOWABLE DISTANCE BETWEEN STAND-OFFS SHALL BE 1300mm.
- D. GROUNDING SHALL EXTEND OUT BEYOND THE STAND-OFF FOOTINGS. THEREFORE, THE SPACING OF THE GROUND RODS FROM THE BASE MAY BE INCREASED ABOVE THAT SHOWN IN DWG. NO. 10U-ED-30M TO ACCOMMODATE THE STAND-OFF FOOTINGS. WHERE NO STAND-OFFS ARE REQUIRED GROUNDING SHALL BE AS PER DWG. NO. 10U-ED-30M.
- E. STAND-OFFS NEED ONLY BE LOCATED ON SIDES WHERE VEHICULAR TRAFFIC MAY BE A HAZARD.



**DISTRIBUTION
UNDERGROUND
STANDARDS**



**TRANSFORMER PAD PROTECTION
AGAINST VEHICULAR TRAFFIC**

DATE: 2008-09-15	REV DATE: 2016-04-12
DRAWN: H. V. HUYNH	STD NO: 6U-ED-40M
APPROVED: <i>Justin Fudge</i>	SHEET: 1 of 1 (R1)

**1Ø PADMOUNT TRANSFORMER
TO CUSTOMER SERVICES FOR CONDOMINIUMS
AND DUPLEX, LINK AND ROW/TOWN HOUSES**

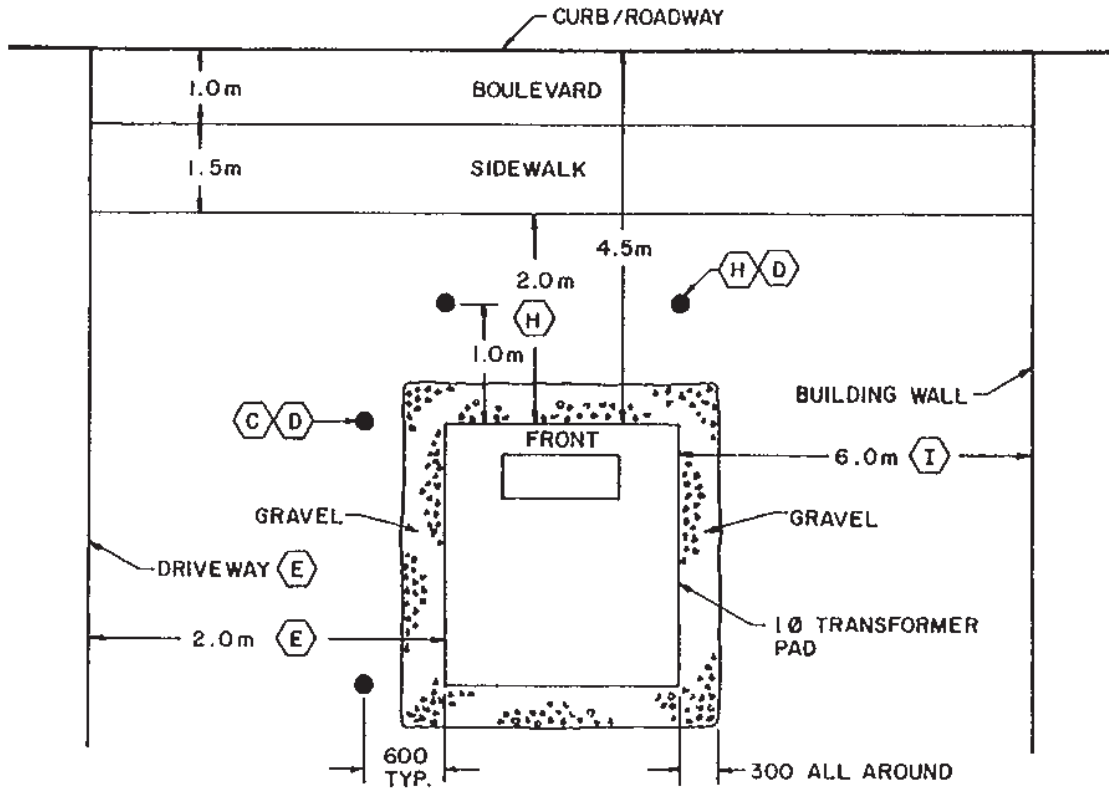

NOTES:

- A . FOR TRANSFORMER PAD CONSTRUCTION REFER TO SECTION '6U' .
- B . TRANSFORMER PAD TO BE SURROUNDED BY GRAVEL AS SHOWN .
- C . SIDE POSTS ARE ONLY REQUIRED IF A DRIVEWAY OR ROADWAY IS LOCATED WITHIN 2.0 m OF THE TRANSFORMER PAD .
- D . ALL POSTS ARE TO BE INSTALLED AS PER DWG. NO. 6U-ED-40M .
- E . NO DRIVEWAY IS TO BE LOCATED WITHIN 1.3 m OF THE TRANSFORMER PAD .
- F . EACH TRANSFORMER SHALL DISPLAY A 'DANGER - HIGH VOLTAGE' SIGN AS PER DWG. NO. 6U-ED-16M .
- G . FOR CONDUIT/TRENCH DETAILS REFER TO DWG. NO.'S 2U-ED-20M AND 2U-ED-21M .
- H . FRONT POSTS ARE ONLY REQUIRED IF THE SIDEWALK IS LOCATED WITHIN 2.0 m OF THE PAD .
- I . PADMOUNT TRANSFORMER IS NOT TO BE LOCATED WITHIN 6.0 m OF BUILDING UNLESS A FIRE RESISTING BARRIER IS EMPLOYED . REFER TO DWG. NO. 6U-ED-12M FOR CONSTRUCTION DETAILS .
- J . ALL DIMENSIONS ARE IN MILLIMETRES UNLESS OTHERWISE SHOWN .

drawn Craig J. Fein designed Craig J. Fein approved Ed Matton
Standards Committee

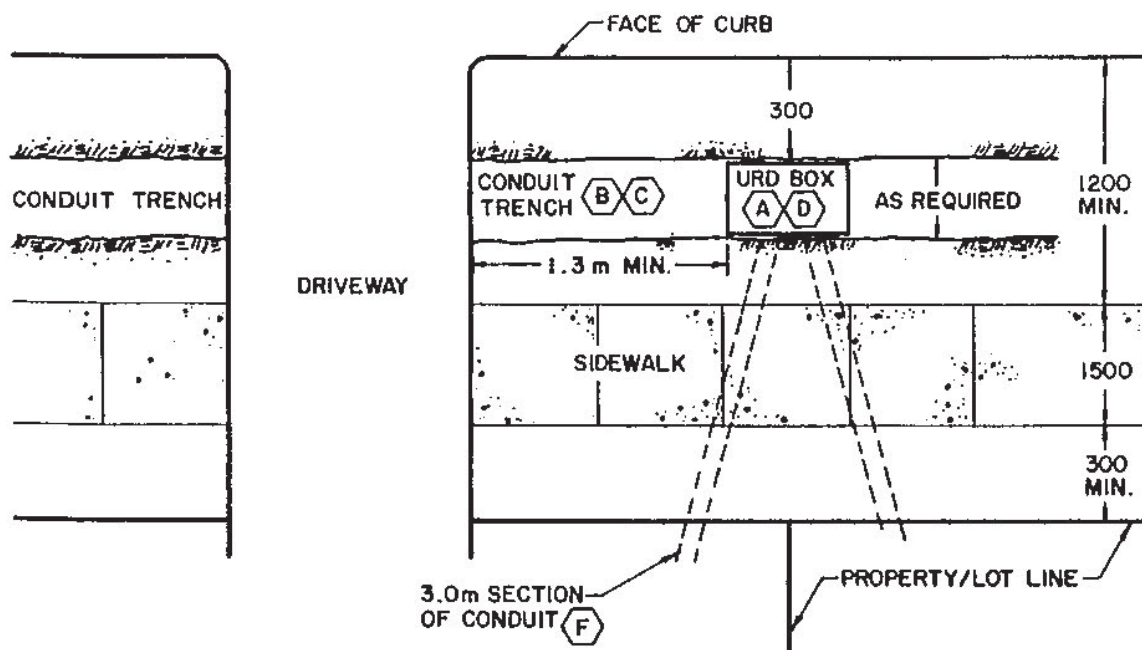
CONDUIT AND URD BOX
- NO RISER POLE -

NOTES:

- A . URD BOX SHALL BE LOCATED ON THE PROPERTY/LOT LINE , BUT NOT CLOSER THAN 1.3m TO A DRIVEWAY .
- B . FOR CLEARANCES AND JOINT USE DETAILS REFER TO SECTION 'IU' .
- C . FOR TRENCHING DETAILS REFER TO DWG. No. 2U-ED-10M .
- D . FOR URD BOX DETAILS REFER TO DWG. No.'s 2U-ED-30M TO 2U-ED-35M FOR SINGLE FAMILY HOMES AND DWG. No.'s 2U-ED-36M TO 2U-ED-39M FOR CONDOMINIUMS , AND DWG. No.'s 2U-ED-40M TO 2U-ED-43M FOR DUPLEX , LINK AND ROW/TOWN HOUSES .
- E . URD BOX SHALL NOT BE LOCATED UNDERNEATH THE SIDEWALK .
- F . CUSTOMER CONDUITS AS REQUIRED BY C.E. CODE PART I , WHICH SHALL BE INSTALLED AT TIME OF URD BOX INSTALLATION .
- G . ALL DIMENSIONS ARE IN MILLIMETRES UNLESS OTHERWISE SHOWN .

drawn Greg N. Fein designed Ray M. Lee approved Matthew
Standards Committee

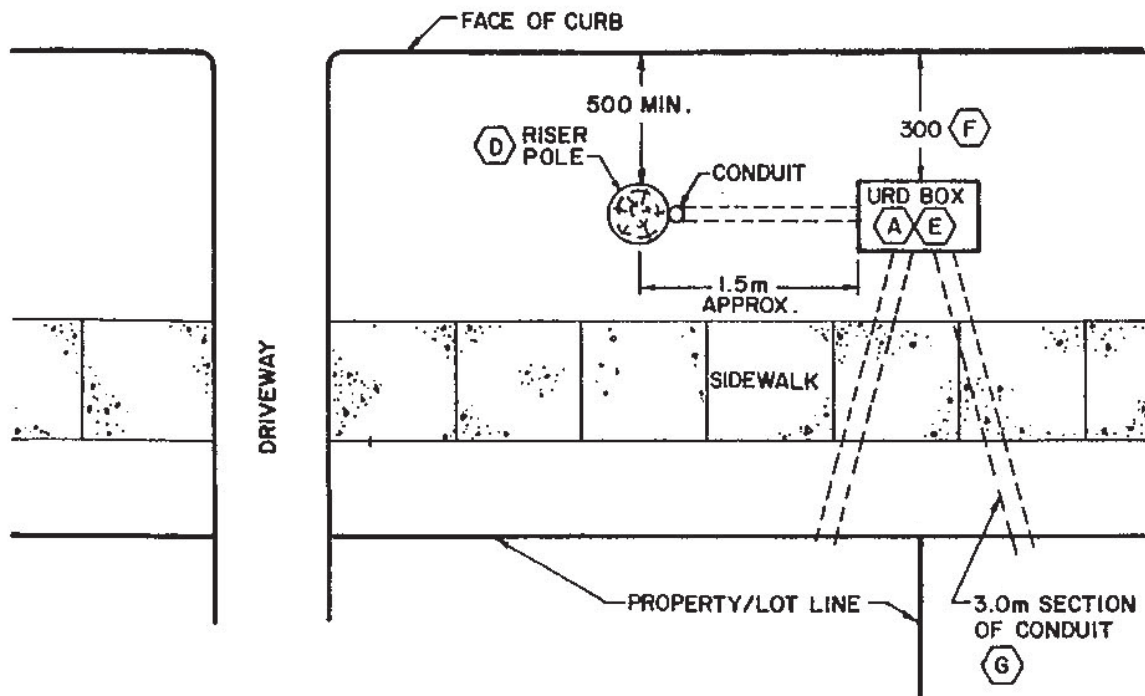
CONDUIT AND URD BOX
- RISER POLE -

NOTES:

- A . URD BOX SHALL BE LOCATED ON THE PROPERTY/LOT LINE , IF POSSIBLE , BUT NOT CLOSER THAN 1.3m TO A DRIVEWAY .
- B . FOR CLEARANCES AND JOINT USE DETAILS REFER TO SECTION 'IU' .
- C . FOR TRENCHING DETAILS REFER TO DWG. No. 2U-ED-10M .
- D . FOR RISER POLE DETAILS REFER TO DWG. No. 5U-ED-20M .
- E . FOR URD BOX DETAILS REFER TO DWG.No.'s 2U-ED-50M TO 2U-ED-53M FOR SINGLE FAMILY HOMES AND DWG.No.'s 2U-ED-40M AND 2U-ED41M FOR DUPLEX , LINK AND ROW/TOWN HOUSES .
- F . URD BOX SHALL NOT BE LOCATED UNDERNEATH THE SIDEWALK .
- G . CUSTOMER CONDUITS AS REQUIRED BY C.E. CODE PART I , WHICH SHALL BE INSTALLED AT TIME OF URD BOX INSTALLATION .
- H . ALL DIMENSIONS ARE IN MILLIMETRES UNLESS OTHERWISE SHOWN .

drawn Carey N. Feary designed Neil W. Hume approved Ken Mattheis
Standards Committee

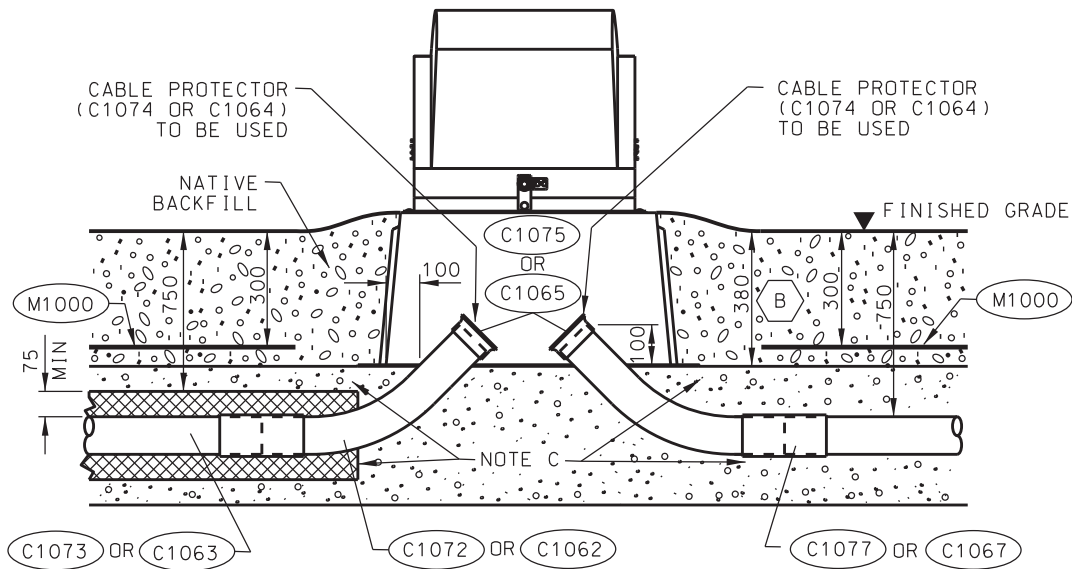

FOR USE WITH CABLE SIZE 3/0 OR SMALLER

NOTES:

- A. LOCATIONS, SETBACKS AND PROTECTION MUST BE AS PER 7U-ED-10M OR 7U-ED-11M AS APPLICABLE.
- B. BURIAL DEPTH MAY BE INCREASED DEPENDING ON THE MANUFACTURER RECOMMENDATION, BURIAL DEPTH SHOWN FOR NORDIC ND-2202442-MG AND HUBBELL P1342542MD.
- C. CONCRETE ENCASED AND OR DIRECT BURIED CONDUITS ARE ACCEPTABLE. FOR DIRECT BURIED CONDUIT CRUSHER DUST IS TO BE USED, FOR CONCRETE ENCASED CONDUIT CRUSHED ROCK TYPE 2 IS TO BE USED, FOR COMBINATION OF DIRECT BURIED CONDUIT AND CONCRETE ENCASED CONDUIT CRUSHER DUST IS TO BE USED.
- D. NATIVE BACKFILLING MATERIAL SHALL NOT CONTAIN ROCKS OVER 50mm IN DIAMETER FOR THE FIRST 300mm OVER CONDUIT.
- E. NATIVE BACKFILL TO BE COMPACTED EVERY 300mm MINIMUM.
- F. PLACE AT LEAST 100mm OF EXCESS FILL AROUND THE JUNCTION BOX TO COMPENSATE FOR SETTLING.
- G. ALL CONDUITS MUST BE CLEANED AND SWABBED, THEN CAPPED FOR PROTECTION.
- H. ALL CONDUIT SHALL HAVE A NYLON FISH LINE (ITEM N1000) INSTALLED PRIOR TO CAPPING.
- I. MARKER TAPE (M1000) SHALL BE INSTALLED AS SHOWN.
- J. REFER TO DWG NO 10U-ED-31M FOR GROUNDING DETAILS.
- K. REFER TO DWG NO 6U-ED-40M FOR PROTECTION AGAINST VEHICULAR TRAFFIC.
- L. ALL DIMENSIONS ARE IN MILLIMETRES UNLESS OTHERWISE SHOWN.



**DISTRIBUTION
UNDERGROUND
STANDARDS**



**INSTALLATION DETAILS FOR SINGLE PHASE
ABOVE GROUND MV JUNCTION BOX**

DATE: 2015-07-09	REV DATE: 2016-04-12
DRAWN: H. V. HUYNH	STD NO: 8U-ED-35M
APPROVED: <i>Justin Fudge</i>	SHEET: 1 of 1 (R1)

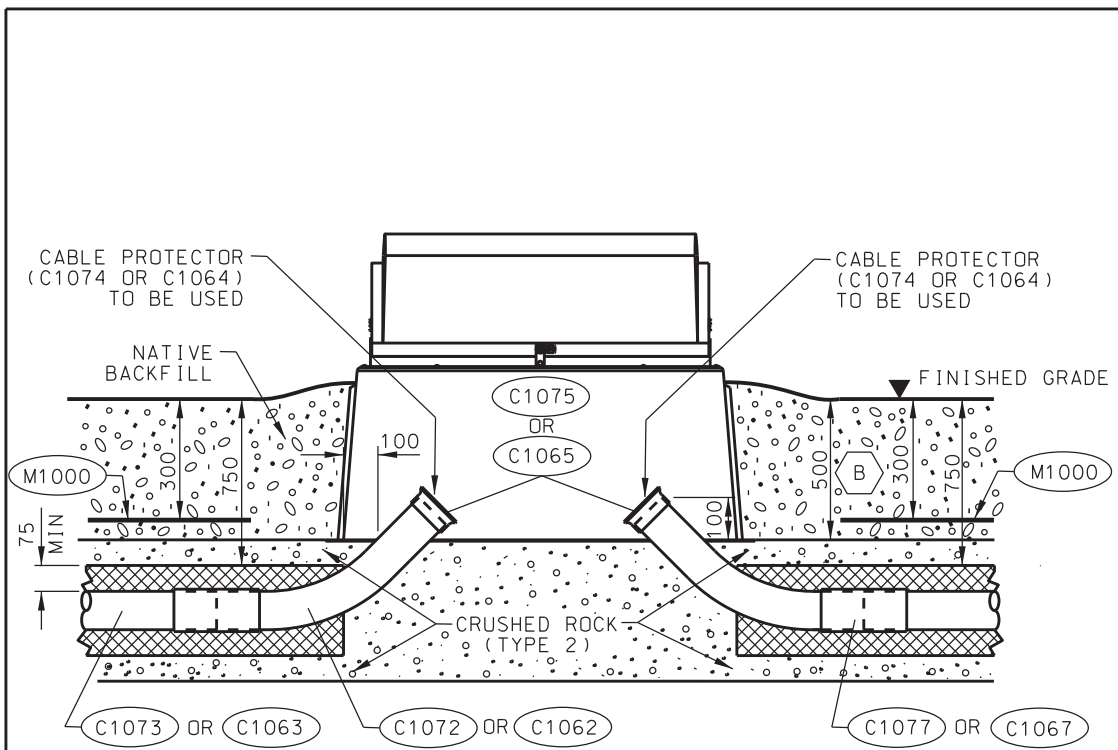

FOR USE WITH CABLE SIZE 3/0 OR SMALLER

NOTES:

- A. LOCATIONS, SETBACKS AND PROTECTION MUST BE AS PER 7U-ED-10M OR 7U-ED-11M AS APPLICABLE.
- B. BURIAL DEPTH MAY BE INCREASED DEPENDING ON THE MANUFACTURER RECOMMENDATION , BURIAL DEPTH SHOWN FOR NORDIC ND-2552450-MG AND HUBBELL P3582548MD.
- C. NATIVE BACKFILLING MATERIAL SHALL NOT CONTAIN ROCKS OVER 50mm IN DIAMETER FOR THE FIRST 300mm OVER CONDUIT.
- D. NATIVE BACKFILL TO BE COMPACTED EVERY 300mm MINIMUM.
- E. PLACE AT LEAST 100mm OF EXCESS FILL AROUND THE JUNCTION BOX TO COMPENSATE FOR SETTLING.
- F. ALL CONDUITS MUST BE CLEANED AND SWABBED, THEN CAPPED FOR PROTECTION.
- G. ALL CONDUIT SHALL HAVE A NYLON FISH LINE (ITEM N1000) INSTALLED PRIOR TO CAPPING.
- H. MARKER TAPE (M1000) SHALL BE INSTALLED AS SHOWN.
- I. REFER TO DWG NO 10U-ED-31M FOR GROUNDING DETAILS.
- J. REFER TO DWG NO 6U-ED-40M FOR PROTECTION AGAINST VEHICULAR TRAFFIC.
- K. ALL DIMENSIONS ARE IN MILLIMETRES UNLESS OTHERWISE SHOWN.

	<p>DISTRIBUTION UNDERGROUND STANDARDS</p>	
	<p>INSTALLATION DETAILS FOR THREE PHASE ABOVE GROUND MV JUNCTION BOX</p>	
	DATE: 2015-07-09	REV DATE: 2016-04-12
	DRAWN: PEH	STD NO: 8U-ED-36M
APPROVED: <i>Justin Fadyen</i>	SHEET: 1 of 1 (R1)	

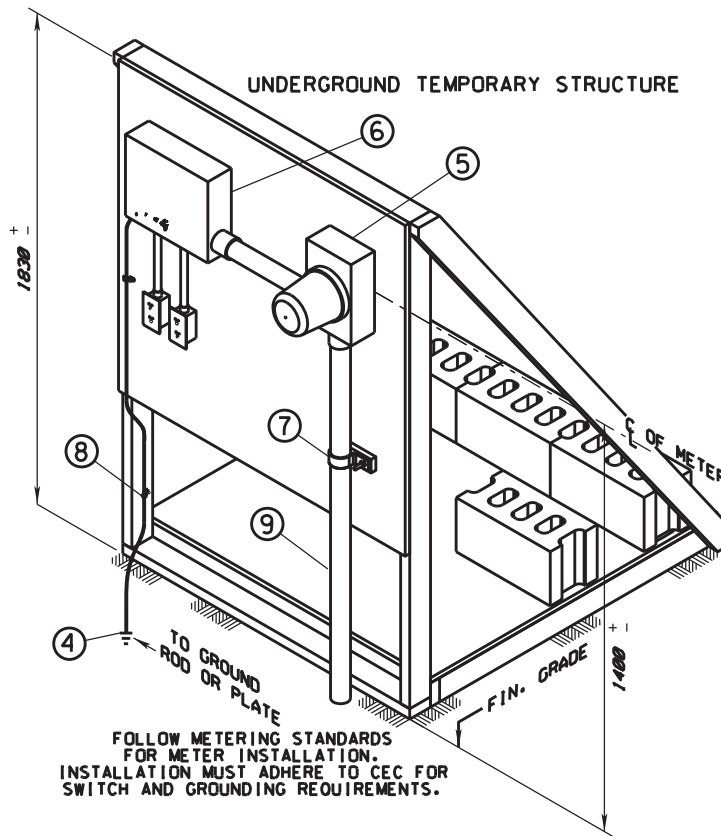

CUSTOMER MATERIAL

- 1 FACE - MINIMUM 4'-0" x 2'-0" x 3/4" PLYWOOD OR BOARDS
- 2 FRAMING - 2" x 4" LUMBER
- 3 BASE - MINIMUM 4'-0" x 2'-0" x 3/4" (SAME AS FACE)
- 4 10' GROUND ROD OR GROUND PLATE
- 5 SQUARE METER SOCKET
- 6 WEATHERPROOF SERVICE ENTRANCE RATED SWITCH
- 7 CONDUIT OR CABLE CLAMP
- 8 GROUND WIRE CLAMP
- 9 RIGID CONDUIT (PVC OR METAL) OR ARMoured CABLE (TECK 90 OR ACWU90)

WEIGHT ON BASE - MINIMUM 330 kg. (ROCK, BLOCK, CONCRETE)

ELECTRICAL - MUST MEET CANADIAN ELECTRICAL CODE FOR TEMPORARY SERVICES. CENTER OF METER TO BE MINIMUM 1.4 M FROM GROUND.

NOTES

1. CARE SHOULD BE TAKEN IF DRIVING GROUND ROD, NOT TO HIT UNDERGROUND CABLE. GROUND PLATE IS RECOMMENDED.
2. STRUCTURE IS TO BE SECURELY ASSEMBLED TO ASSURE RIGIDITY & MOUNTED ON LEVEL GROUND.
3. CONDUIT TO BE SECURELY FASTENED TO STRUCTURE.
4. STRUCTURE MUST NOT IMPEDE ACCESS TO URD BOX.
5. CARE SHOULD BE TAKEN THAT URD BOX AREA IS LEFT IN A SAFE MANNER.
6. SERVICE SWITCH MUST BE CAPABLE OF BEING LOCKED.
7. WHEN MORE THAN ONE SET OF WIRE CONDUCTOR IS INSTALLED IN URD BOX, TEMPORARY WIRE CONDUCTOR MUST BE IDENTIFIED BY LABELLING.
8. STRUCTURE TO BE PLACED ON CUSTOMER PROPERTY - NOT TO IMPEDE PEDESTRIAN AREA ON SIDEWALKS OR BLOCK FIRE HYDRANTS.

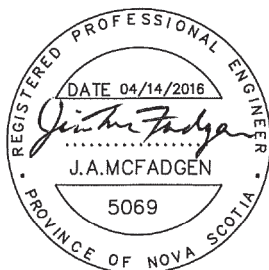

**DISTRIBUTION
UNDERGROUND
STANDARDS**



UNDERGROUND TEMPORARY SERVICE

DATE: 2008-08-14	REV DATE: 2016-04-12
DRAWN: H. V. HUYNH	STD NO: 8U-ED-40M
APPROVED: <i>J.A. MCFADGEN</i>	SHEET: 1 of 1 (R1)

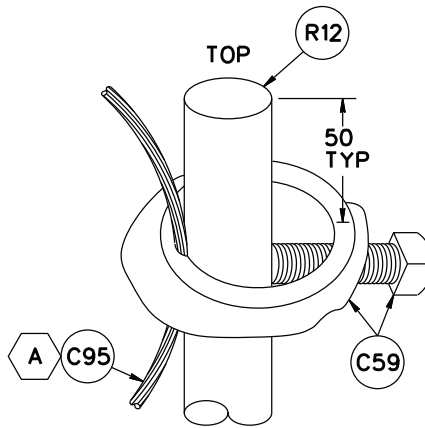

PADMOUNT TRANSFORMERS

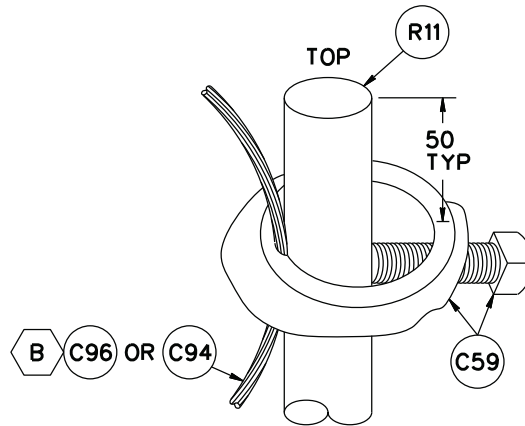

DISTRIBUTION LINES

NOTES:

- A. FOR PADMOUNT TRANSFORMER INSTALLATIONS THE GROUND WIRE SHALL PASS THROUGH THE CONNECTOR IN A CONTINUOUS LOOP AROUND THE TRANSFORMER PAD. REFER TO DWG. No. 10U-ED-30M.
- B. FOR DISTRIBUTION LINES WHERE THREE GROUND RODS ARE USED THE GROUND WIRE SHALL PASS THROUGH THE CONNECTOR IN A CONTINUOUS LOOP AROUND THE POLE. REFER TO DWG. No. 10U-ED-10M.

(SAME AS G-ED-11M)



DISTRIBUTION STANDARDS



**CONNECTION DETAILS FOR
GROUND RODS**

DATE:	2008-08-14	REV DATE:	2016-04-12
DRAWN:	M. HALASZ	STD NO:	10U-ED-11M
APPROVED:	J. A. MCFADGEN	SHT NO:	1 OF 1 (R1)

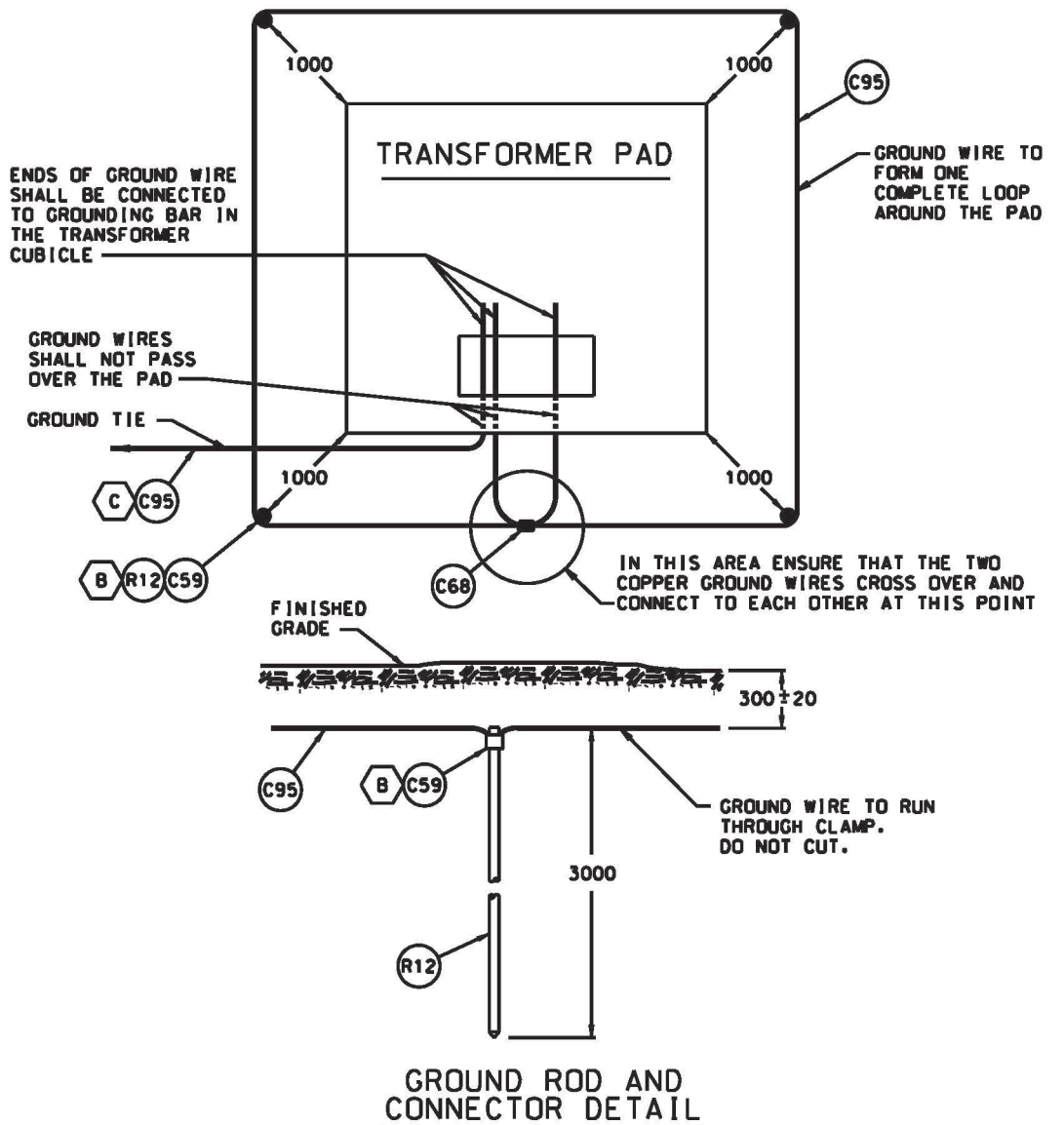

GROUND ROD AND CONNECTOR DETAIL

NOTES:

- A. GROUNDING SHALL BE IN ACCORDANCE WITH SECTION 36 OF THE LATEST EDITION OF THE CANADIAN ELECTRICAL CODE, PART I.
- B. REFER TO DWG. NO. 10U-ED-11M FOR GROUND ROD CONNECTION DETAILS.
- C. THE GROUND TIE SHALL BE A BARE COPPER CONDUCTOR INSTALLED UNDERNEATH THE CONCRETE ENCASED DUCTBANK OR ADJACENT TO THE DIRECT BURIED CONDUITS.
- D. THE MINIMUM WIRE SIZE SHALL BE #2/0 AWG.
- E. THE GROUND TIE SHALL INTERCONNECT THE PADMOUNT GROUND TO THE RISER POLE GROUND ROD(S) AND ANY OTHER PADMOUNT GROUND.
- F. UNDER SPECIAL CIRCUMSTANCES A CUSTOMER GROUND TIE FROM THE PAD TO THE CUSTOMER SERVICE SWITCH MAY BE REQUIRED BY THE INSPECTION AUTHORITY.

SAME AS (G-ED-30M)

	<p>DISTRIBUTION UNDERGROUND STANDARDS</p>	
	<p>GROUNDING DETAILS FOR PADMOUNT TRANSFORMER</p>	
DATE: 2008-04-14	REV DATE: 2016-04-12	
DRAWN: H. V. HUYNH	STD NO: 10U-ED-30M	
APPROVED: <i>J. H. H. H.</i>	SHEET: 1 of 1 (R1)	

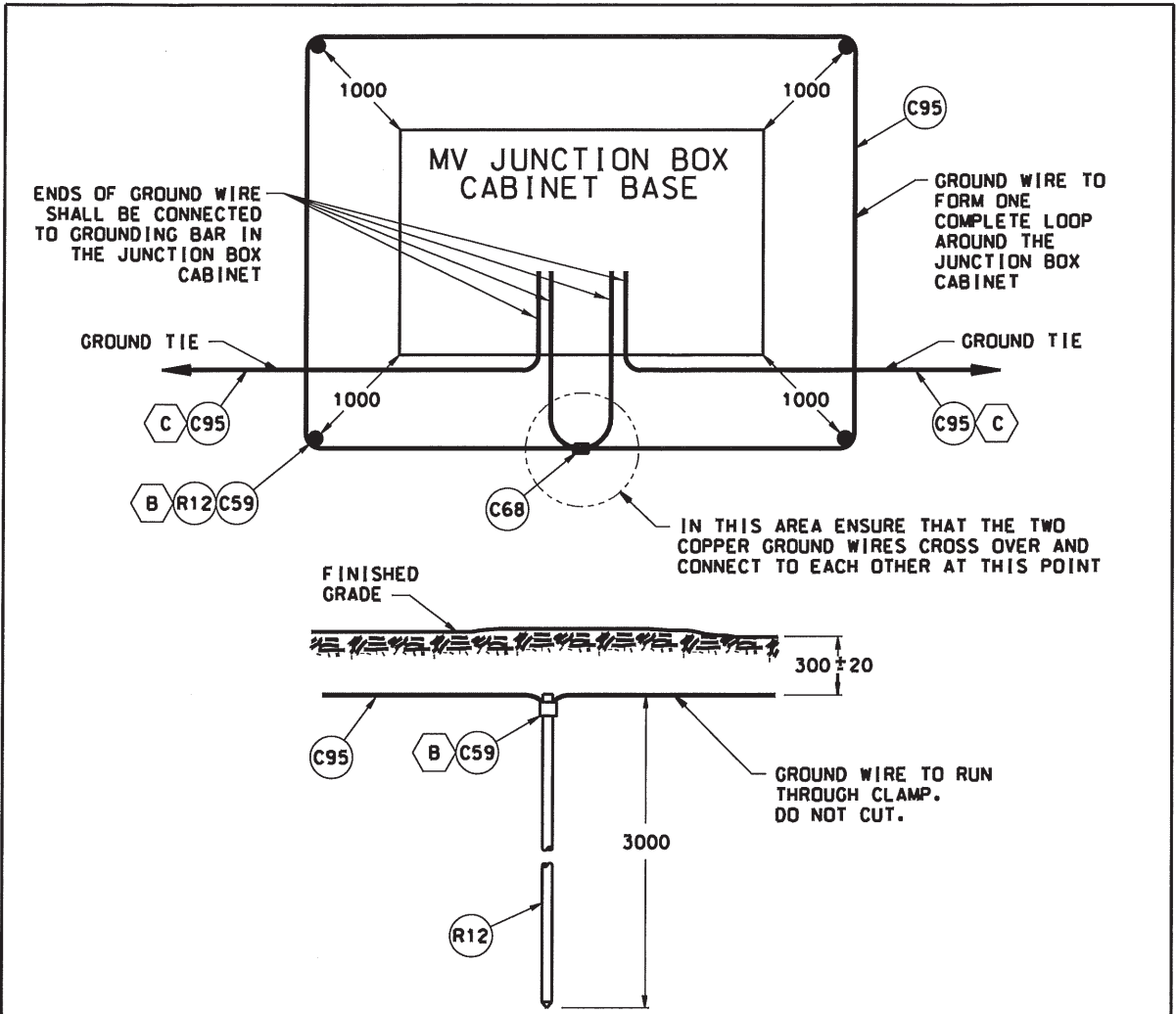

GROUND ROD AND CONNECTOR DETAIL

NOTES:

- A. GROUNDING SHALL BE IN ACCORDANCE WITH SECTION 36 OF THE LATEST EDITION OF THE CANADIAN ELECTRICAL CODE, PART ONE.
- B. REFER TO DWG. NO. 10U-ED-11M FOR GROUND ROD CONNECTION DETAILS.
- C. THE GROUND TIE SHALL BE A BARE COPPER CONDUCTOR INSTALLED UNDERNEATH THE CONCRETE ENCASED DUCTBANK OR THE DIRECT BURIED CONDUITS.
- D. THE MINIMUM WIRE SIZE SHALL BE #2/0 AWG.
- E. THE GROUND TIE SHALL INTERCONNECT TO THE JUNCTION BOX GROUND TO THE RISER POLE GROUND ROD(S) AND ANY OTHER JUNCTION BOX/PADMOUNT GROUND.
- F. UNDER SPECIAL CIRCUMSTANCES A CUSTOMER GROUND TIE FROM THE JUNCTION BOX TO THE CUSTOMER SERVICE SWITCH MAY BE REQUIRED BY THE INSPECTION AUTHORITY.
- G. ALL DIMENSIONS ARE IN MILLIMETRES UNLESS OTHERWISE SHOW.



**DISTRIBUTION
UNDERGROUND
STANDARDS**



**GROUNDING DETAILS FOR
ABOVE GROUND MV JUNCTION BOX**

DATE: 2015-07-09	STD NO: 10U-ED-31M
DRAWN: PEH	Sheet 1 of 1
APPROVED: <i>Justin Fudge</i>	

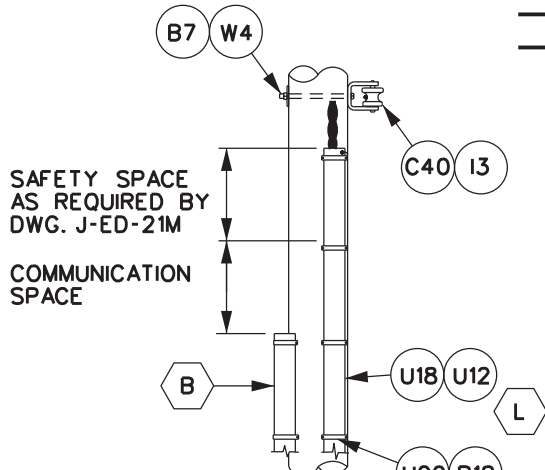
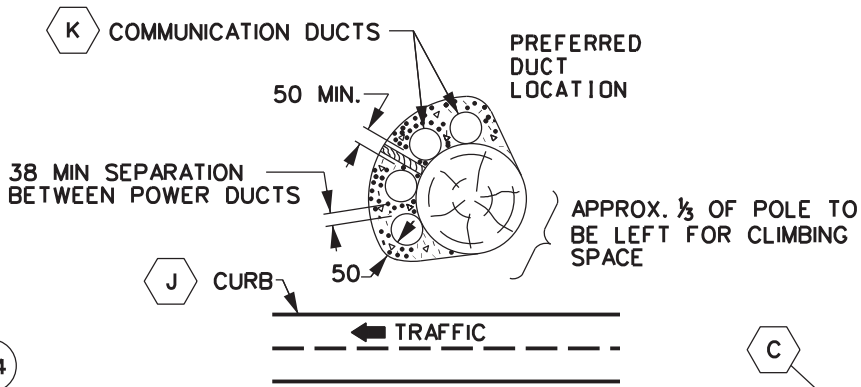

SPARE 100 PVC RIGID CONDUIT TO BE CAPPED OFF WITH A NYLON FISH WIRE INSIDE (ITEM U16)

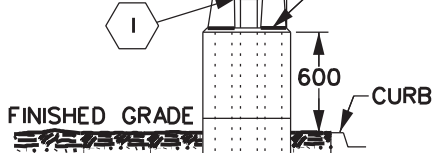

25 mm X 300 mm WOODEN PLANK

GROUND TIE

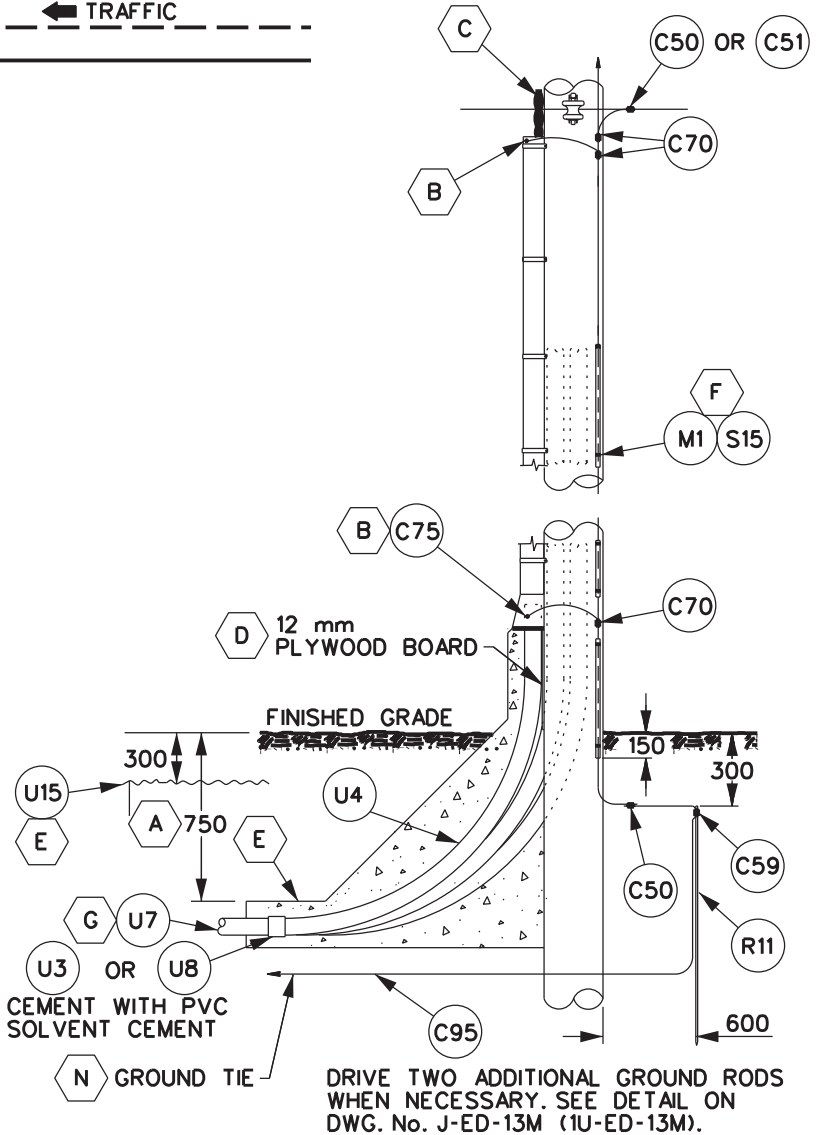

NOTES:
SEE SHEET 2 OF 2 FOR NOTES

NSPI & BELL CANADA JOINT-USE DISTRIBUTION STANDARDS

JOINT USE DUCT TERMINATION FOR UNDERGROUND PRIMARY SERVICE (MORE THAN 750 VOLTS)

Jim McFadgen P. Eng.

FOR NSPI:
JIM MCFADGEN, P.ENG

Stephen Cumming

FOR BELL:
STEPHEN CUMMING, P.ENG

DRAWN:	M.HALASZ
REV DATE:	2021-12-13
STD NO:	J-ED-14M
SHT:	1 OF 2

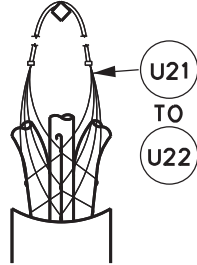



DETAIL OF KELLEMS GRIP

NOTES:

- A. FOR ROADWAY/DRIVEWAY REQUIREMENTS, DEPTH OF BURIAL TO BE 1000mm. (NSPI: REFER TO DWG. No. 1U-ED-44M).
- B. REFER TO DWG. No. 10U-ED-12M FOR BONDING OF POWER CABLE GUARDS. TELECOMMUNICATIONS CABLE GUARD AND/OR CONDUITS ARE TO BE BONDED TO GROUND IF THEY ARE METALLIC.
- C. REFER TO SECTION '5U' FOR OVERHEAD POWER TERMINATION DETAILS.
- D. DUCTS SHALL BE SECURED TO THE POLE WITH CONDUIT STRAPS AND HAVE A 12mm THICK PLYWOOD BOARD SPACER BEFORE CONCRETE IS POURED.
- E. DUCT RUNS SHALL BE FORMED BY THE CUSTOMER OR THEIR AGENT AND INSPECTED BY NSPI AND COMMUNICATION REPRESENTATIVES PRIOR TO POURING OF CONCRETE, MARKER TAPE TO BE INSTALLED AS SHOWN.
- F. FOR GROUNDING DETAILS REFER TO J-ED-13M.
- G. 100mm DUCTS SHALL NORMALLY BE USED BY NSPI. IN SPECIAL CIRCUMSTANCES, WHEN MORE THAN THREE 90° BENDS ARE NEEDED BETWEEN CABLE PULLING POINTS, OR DUCT RUN EXCEEDS 92mm, 125mm DUCTS SHALL BE USED.
- H. ANY METAL USED FOR FORMING CONCRETE AT THE BASE OF POLE SHALL BE REMOVED.
- I. ALL DUCTS MUST BE CLEANED AND SWABBED, THEN CAPPED FOR PROTECTION.
- J. DUCTS SHALL NOT BE INSTALLED ON THE CURB OR TRAFFIC SIDE OF THE POLE.
- K. ON DEADEND STRUCTURES THE POSITION OF THE DUCTS MAY BE REVERSED TO FACILITATE COMMUNICATIONS DEADENDING.
- L. STRAP CABLED UNDER GUARD EVERY 3000mm AND CABLE GUARD TO POLE EVERY 1200mm.
- M. NUMBER, SIZE AND TYPE OF CONDUITS/DUCTS TO BE SPECIFIED BY THE USER UTILITY.
- N. GROUND TIE TO BE INSTALLED BENEATH THE DUCTBANK AND CONNECTED TO THE DOWN STREAM DISTRIBUTION EQUIPMENT GROUND.
- O. ALL DIMENSIONS ARE IN MILLIMETERS UNLESS OTHERWISE SHOWN.

NSPI & BELL CANADA JOINT-USE DISTRIBUTION STANDARDS

JOINT USE DUCT TERMINATION FOR UNDERGROUND PRIMARY SERVICE (MORE THAN 750 VOLTS)

 FOR NSPI: JIM MCFADGEN, P.ENG	 FOR BELL: STEPHEN CUMMINGER, P.ENG	DRAWN: M.HALASZ
		REV DATE: 2021-12-13
		STD NO: J-ED-14M
		SHT: 2 OF 2

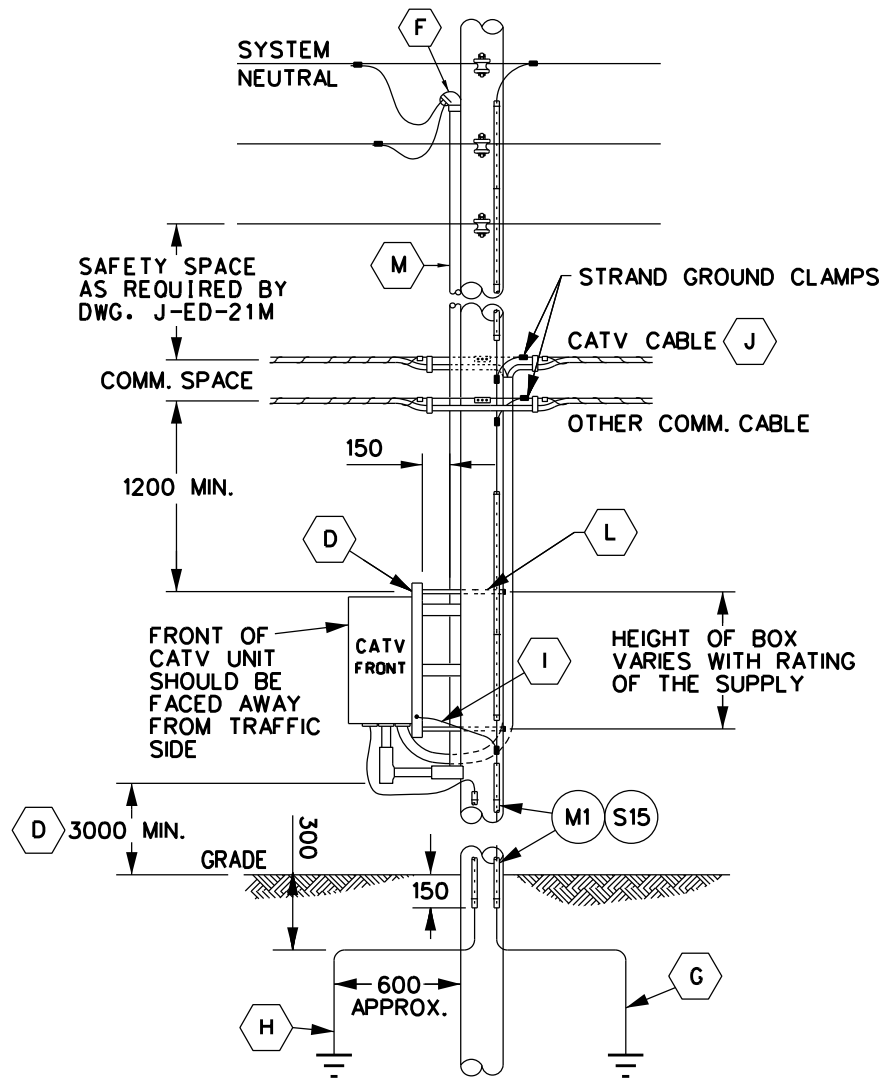

NOTES:

A. SEE SHEET 2 OF 2 FOR NOTES.

NSPI & BELL CANADA JOINT-USE DISTRIBUTION STANDARDS

LOCATION OF REMOTE POWER CABINET FOR CATV

Jim McFadgen P. Eng.

Stephen Cumming

FOR NSPI:
JIM MCFADGEN, P.ENG

FOR BELL:
STEPHEN CUMMING, P.ENG

DRAWN:	M.HALASZ
REV DATE:	2023-02-03
STD NO:	J-ED-15M
SHT:	1 OF 2

NOTES:

- A. NSP SERVICES SAFE CLEARANCE REPORT SHALL BE ISSUED FOR ALL INSTALLATIONS.
- B. POWER CABINET NOT TO BE INSTALLED ON ANY POLE THAT HAS:
 - a) A THREE PHASE GANG OPERATED SWITCH.
 - b) HAS ANY POWER CABLE OR CONDUIT RISERS.
 - c) HAS A THREE PHASE TAKE-OFF.
 - d) ANY POLE WITH COMMUNICATIONS CABLE OR CONDUIT RISERS.
 - e) HAS OTHER COMMUNICATIONS EQUIPMENT INSTALLED ON IT.
 - f) WHERE IT MAY IMPEDE THE USE OF STRAND MOUNTED WORK EQUIPMENT.
 - g) CABINET MUST BE INSTALLED ON THE OPPOSITE SIDE OF POLE FROM ANY LARGE SPLICE.
 - h) THERE MAY NOT BE MORE THAN ONE SERVICE ENTRANCE GROUND ELECTRODE AT THE BASE OF EACH POLE. THIS LIMITS THE NUMBER OF POWERED DEVICES OF ANY TYPE TO ONE PER POLE.
 - i) EXCEPTIONS TO THE ABOVE MUST BE APPROVED BY BOTH NSPI AND BELL ENGINEERING.
- C. PLACE RIGID PVC CONDUIT AS FAR AWAY AS IS PRACTICAL FROM TELEPHONE PLANT.
- D. NO PART OF THE POWER SUPPLY BOX MAY PROTRUDE INTO A VEHICLE LANE REGARDLESS OF WHICH SIDE OF THE POLE THE BOX OR LANE IS ON. (THIS INCLUDES DRIVEWAY SPACES)
- E. THE CABINET SHALL BE OFFSET A MIN. 150mm FROM THE POLE TO ALLOW FOR CLIMBING SPACE.
- F. WEATHERHEAD SHALL BE 400mm BELOW NEUTRAL LINE WHEN NO SECONDARY CONDUCTOR(S) ARE PRESENT.
- G. IF THERE IS NO NSPI SYSTEM GROUND ON THE POLE, THEN ONE MUST BE INSTALLED AS REQUIRED BY NSPI STANDARD J-ED-13M.
- H. THE SERVICE GROUND IS REQUIRED SEPARATELY FROM THE NSPI SYSTEM GROUND ON ALL INSTALLATIONS AS PER CANADIAN ELECTRICAL CODE, PART 1.
- I. ALL METALLIC ENCLOSURES SHALL BE BONDED TO GROUND. CASE GROUNDS FOR THE CATV CABINET, AND ALL EXISTING STRANDS ARE TO BE BONDED TO THE NSPI DOWN GROUND.
- J. ACTUAL CATV GAIN LOCATION MAY VARY IN THE FIELD.
- K. ALL LOCATIONS SHALL BE JOINTLY SCOPED BY NSPI AND THE COMMUNICATION COMPANY INVOLVED.
- L. MOUNTING BOLTS ARE TO BE CUT OFF WITH A MAXIMUM OF 12mm OF EXPOSED THREAD PAST THE NUT AND TREATED WITH COLD GALVANIZED PAINT TO PREVENT CORROSION.
- M. COMMUNICATION COMPANY SHALL PROVIDE A MINIMUM OF 1000mm OF WIRE AND CONDUIT FOR NSPI TO COMPLETE THE CONNECTION.
- N. ALL DIMENSIONS ARE IN MILLIMETERS UNLESS OTHERWISE SHOWN.

NSPI & BELL CANADA JOINT-USE DISTRIBUTION STANDARDS

LOCATION OF REMOTE POWER CABINET FOR CATV

Jim McFadgen P. Eng.

Stephen Cumming

FOR NSPI:
JIM MCFADGEN, P.ENG

FOR BELL:
STEPHEN CUMMING, P.ENG

DRAWN:	M.HALASZ
REV DATE:	2023-02-03
STD NO:	J-ED-15M
SHT:	2 OF 2

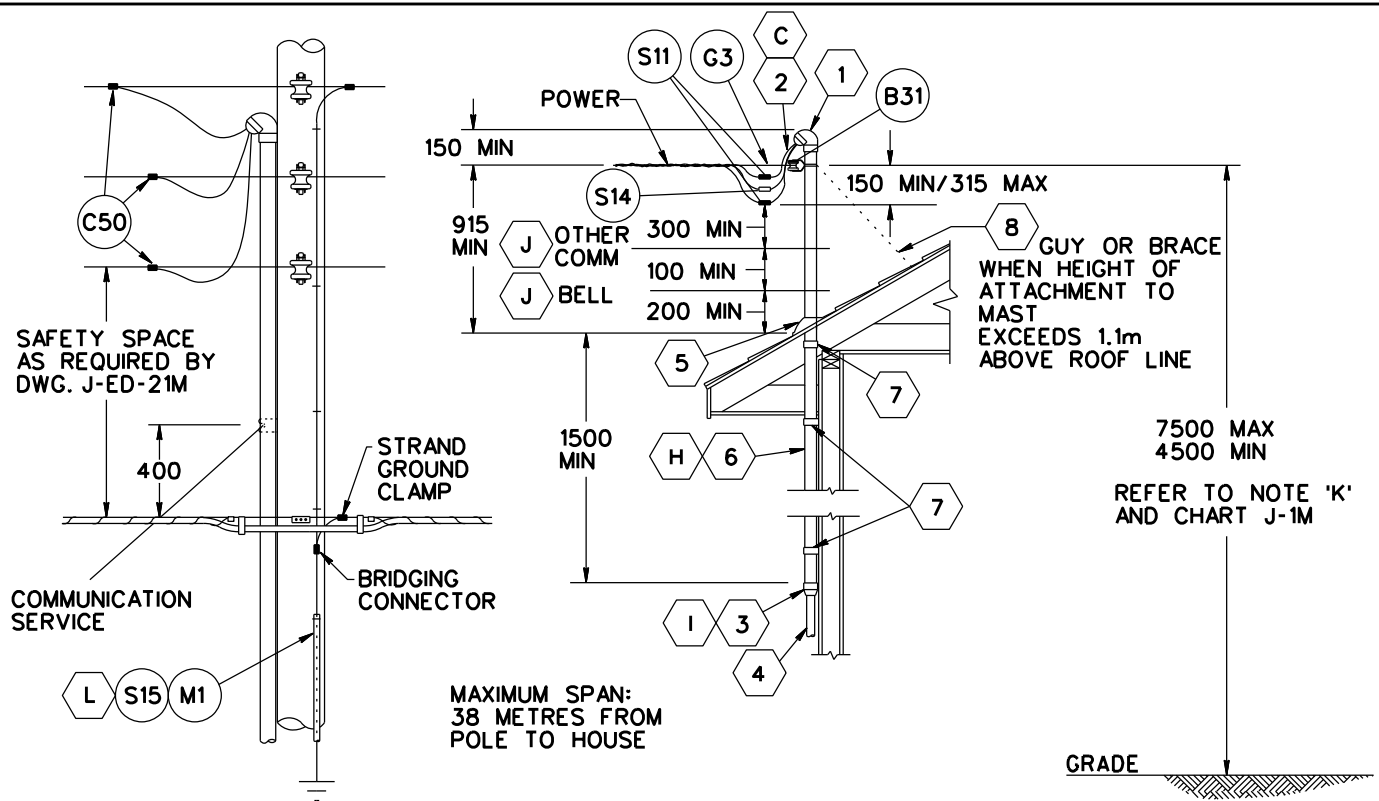

CUSTOMER'S MATERIAL (No.)

- | | |
|--|---|
| 1. SERVICE HEAD | 6. MAST SUPPORT MEMBER |
| 2. SERVICE ENTRANCE CONDUCTOR, INSULATED | 7. SERVICE MAST CLAMP, GALVANIZED, 2 1/2" |
| 3. OFFSET CONDUIT REDUCER | 8. 6mm GALVANIZED STEEL WIRE |
| 4. RIGID CONDUIT | 9. METER BASE |
| 5. ROOF FLASHING | |

NOTES:

- A. THE CUSTOMER SHALL BE RESPONSIBLE FOR INSTALLING THE SERVICE BRACKET AND THE MAST IN A LOCATION SATISFACTORY TO BOTH THE INSPECTION DEPT. AND THE SUPPLY AUTHORITY, AND ENSURING THE ATTACHMENT WILL SUPPORT A HORIZONTAL LOAD OF 3kN.
- B. MATERIAL REQUIRED FOR SERVICE ATTACHMENT SHALL BE SUPPLIED BY NSP.
- C. CUSTOMER'S SERVICE ENTRANCE CONDUCTORS SHALL EACH EXTEND NOT LESS THAN 750mm BEYOND THE SERVICE HEAD.
- D. SERVICE ATTACHMENT SHALL BE INSTALLED A MINIMUM OF 150 mm BELOW THE SERVICE HEAD.
- E. DRIP LOOP ON SERVICE CONDUCTOR TO BE LEFT AT THE POLE AND HOUSE CONNECTION.
- F. REFER TO CHART SS-1M FOR RECOMMENDED SIZES OF TRIPLEX CABLE TO BE USED.
- G. ANCHORING AND GUYING TO BE IN ACCORDANCE WITH SECTION 'A'.
- H. 2 1/2" GALVANIZED STEEL MAST TUBING OR 2 1/2" MINIMUM GALVANIZED RIGID STEEL CONDUIT ARE ACCEPTABLE AS SERVICE MASTS. RIGID ALUMINUM CONDUIT IS NOT ACCEPTABLE.
- I. ITEM No. 3 IS NOT REQUIRED WHEN THE MAST IS CONNECTED DIRECTLY TO A 2 1/2" HUB ON THE METER CONNECTION BOX.
- J. COMMUNICATION DROP WIRE MAY BE ATTACHED TO THE MAST WITH MINIMUM CLEARANCES AS SHOWN.
- K. AT THE DISCRETION OF THE NSP FIELD ENGINEER, OR THEIR REPRESENTATIVE, AND BELL DISTRICT MANAGER (O.P.E.) OR THEIR REPRESENTATIVE, MINIMUM SERVICE ATTACHMENT HEIGHT MAY BE INCREASED OR DECREASED TO MEET CLEARANCE REQUIREMENTS UNDER MAXIMUM SAG CONDITIONS AS SPECIFIED IN CHART J-1M.
- L. FOR GROUNDING DETAILS REFER TO DWG. J-ED-13M.
- M. ALL DIMENSIONS ARE IN MILLIMETERS UNLESS OTHERWISE SHOWN.

NSPI & BELL CANADA JOINT-USE DISTRIBUTION STANDARDS

JOINT-USE CLEARANCES SERVICE ATTACHMENTS FOR SINGLE FAMILY DWELLINGS

<p><i>Jim McFadgen P. Eng.</i></p> <p>FOR NSPI; JIM MCFADGEN, P.ENG</p>	<p><i>Stephen Cumming</i></p> <p>FOR BELL; STEPHEN CUMMING, P.ENG</p>	DRAWN: M.HALASZ
		REV DATE: 2022-05-20
		STD NO: J-ED-23M
		SHT: 1 OF 1

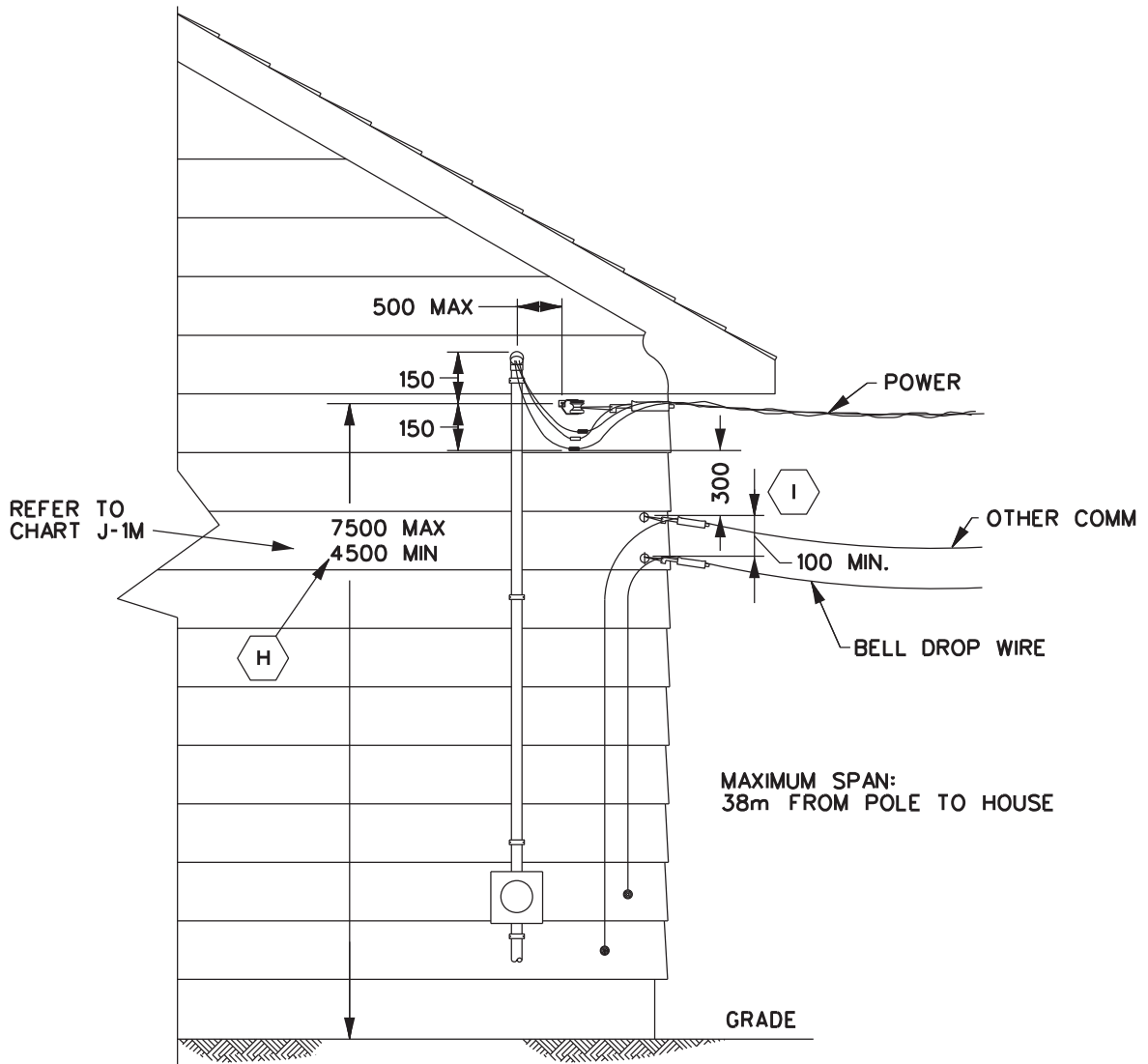

NOTES:

- A. THE CUSTOMER SHALL BE RESPONSIBLE FOR INSTALLING THE POWER SERVICE ATTACHMENT DEVICE ON NEW HOMES AT THE TIME OF CONSTRUCTION AND ENSURING THE ATTACHMENT WILL SUPPORT A HORIZONTAL LOAD OF 3kN.
- B. MATERIAL REQUIRED FOR POWER SERVICE ATTACHMENT SHALL BE SUPPLIED BY NSP.
- C. CUSTOMER'S SERVICE ENTRANCE CONDUCTOR SHALL EACH EXTEND NOT LESS THAN 750mm BEYOND THE SERVICE HEAD.
- D. SERVICE ATTACHMENT SHALL BE INSTALLED A MINIMUM OF 150 mm BELOW THE SERVICE HEAD.
- E. DRIP LOOP ON SERVICE CONDUCTORS TO BE LEFT AT THE POLE AND HOUSE CONNECTIONS.
- F. REFER TO CHART SS-1M FOR RECOMMENDED SIZES OF TRIPLEX CABLE TO BE USED.
- G. ANCHORING AND GUYING TO BE IN ACCORDANCE WITH SECTION 'A'.
- H. AT THE DISCRETION OF NSPI FIELD ENGINEERING, OR THEIR REPRESENTATIVE, AND BELL DISTRICT MANAGER (O.P.E.) OR THEIR REPRESENTATIVE, MINIMUM SERVICE ATTACHMENT HEIGHT MAY BE INCREASED OR DECREASED TO MEET CLEARANCE REQUIREMENTS UNDER MAXIMUM SAG CONDITIONS AS SPECIFIED IN CHART J-1M.
- I. COMMUNICATION DROP WIRE SHALL BE ATTACHED WITH MINIMUM CLEARANCES AS SHOWN.
- J. ALL DIMENSIONS ARE IN MILLIMETERS UNLESS OTHERWISE SHOWN.

NSPI & BELL CANADA JOINT-USE DISTRIBUTION STANDARDS

JOINT-USE CLEARANCES AT SERVICE ATTACHMENTS TERMINATED ON SINGLE FAMILY DWELLINGS

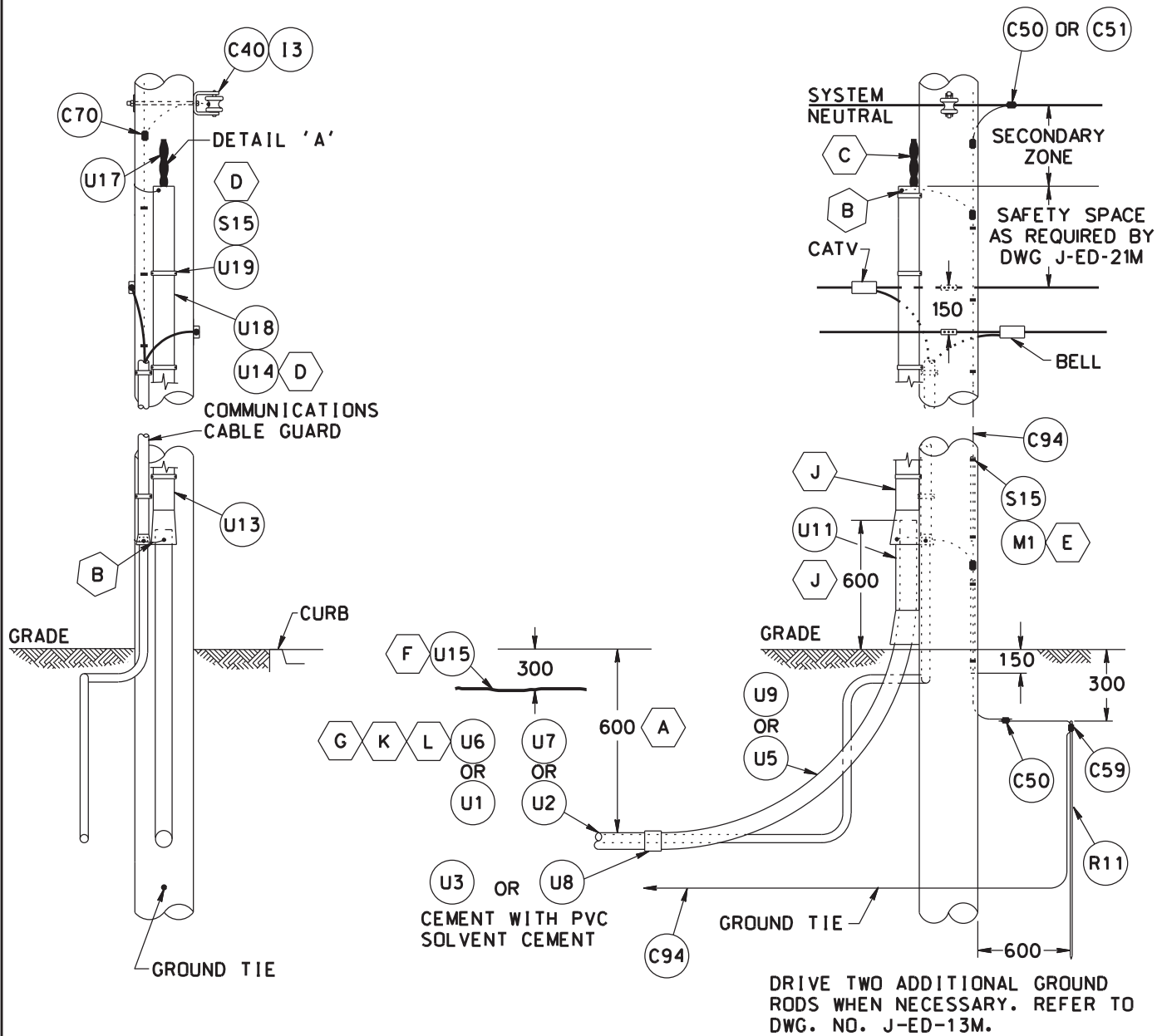

<p><i>Jim McFadgen P. Eng.</i></p> <p>FOR NSPI; JIM MCFADGEN, P.ENG</p>	<p><i>Stephen Cumming</i></p> <p>FOR BELL; STEPHEN CUMMING, P.ENG</p>	DRAWN: M.HALASZ
		REV DATE: 2021-12-13
		STD NO: J-ED-24M
		SHT: 1 OF 1



NOTES:
 REFER TO SHEET 2 OF 2 FOR GENERAL NOTES.

NSPI & BELL CANADA JOINT-USE DISTRIBUTION STANDARDS

JOINT USE DUCT TERMINATION FOR UNDERGROUND SECONDARY SERVICES (750 VOLTS OR LESS)

 FOR NSPI; JIM MCFADGEN, P.ENG	 FOR BELL; STEPHEN CUMMING, P.ENG	DRAWN: M.HALASZ
		REV DATE: 2022-03-11
		STD NO: J-ED-25M
		SHT: 1 OF 2

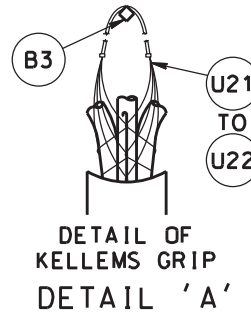
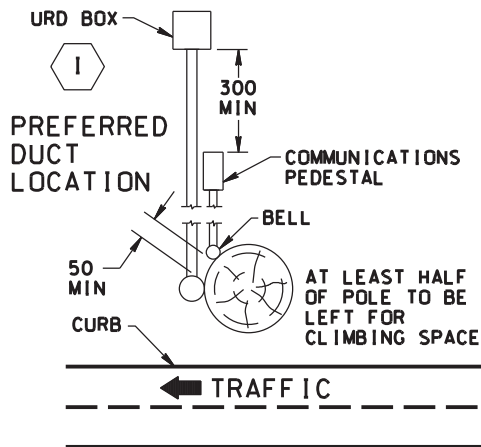

NOTES:

- A. DEPTH SHALL BE INCREASED TO 1000mm IN VEHICULAR AREAS.
- B. REFER TO DWG. NO. G-ED-12M FOR BONDING OF POWER CABLE GUARD.
- C. REFER TO SECTION 'OU' FOR OVERHEAD POWER TERMINATION DETAILS.
- D. STRAP CABLES UNDER GUARD EVERY 3000mm AND CABLE GUARD TO POLE EVERY 1200mm.
- E. FOR GROUNDING DETAILS REFER TO DWG. J-ED-13M.
- F. MARKER TAPE (ITEM U15) SHALL BE INSTALLED AS SHOWN.
- G. ALL CONDUITS AND FITTINGS SHALL BE CSA APPROVED. CONDUIT RUNS SHALL BE CONSTRUCTED BY THE CUSTOMER OR THEIR AGENT AND INSPECTED BY NSP AND BELL REPRESENTATIVES PRIOR TO BACKFILLING.
- H. REFER TO DWG. NO. J-ED-12M FOR SERVICE TRENCH DETAILS.
- I. NSP: REFER TO U/G STANDARDS MANUAL FOR CONDUIT AND URD BOX LOCATION. CONDUITS SHALL NOT BE INSTALLED ON THE CURB OR TRAFFIC SIDES OF THE POLE.
- J. RIGID PVC CONDUIT TO EXTEND UP THE POLE 600mm WITH CABLE GUARD OVERLAPPING THE CONDUIT.
- K. RIGID PVC CONDUIT MUST BE CLEANED AND SWABBED THEN CAPPED FOR PROTECTION.
- L. ALL CONDUIT SHALL HAVE A NYLON FISH LINE (ITEM U16) INSTALLED PRIOR TO CAPPING.
- M. NUMBER, SIZE AND TYPE OF CONDUITS/DUCTS TO BE SPECIFIED BY THE USER UTILITY.
- N. CABLE GUARD IS NOT REQUIRED WHEN ARMORED CABLE (TECK) IS USED.
- O. ALL DIMENSIONS ARE IN MILLIMETERS UNLESS OTHERWISE SHOWN.

NSPI & BELL CANADA JOINT-USE DISTRIBUTION STANDARDS

JOINT USE DUCT TERMINATION FOR UNDERGROUND SECONDARY SERVICES (750 VOLTS OR LESS)

 FOR NSPI; JIM MCFADGEN, P.ENG	 FOR BELL; STEPHEN CUMMING, P.ENG	DRAWN: M.HALASZ
		REV DATE: 2022-03-11
		STD NO: J-ED-25M
		SHT: 2 OF 2

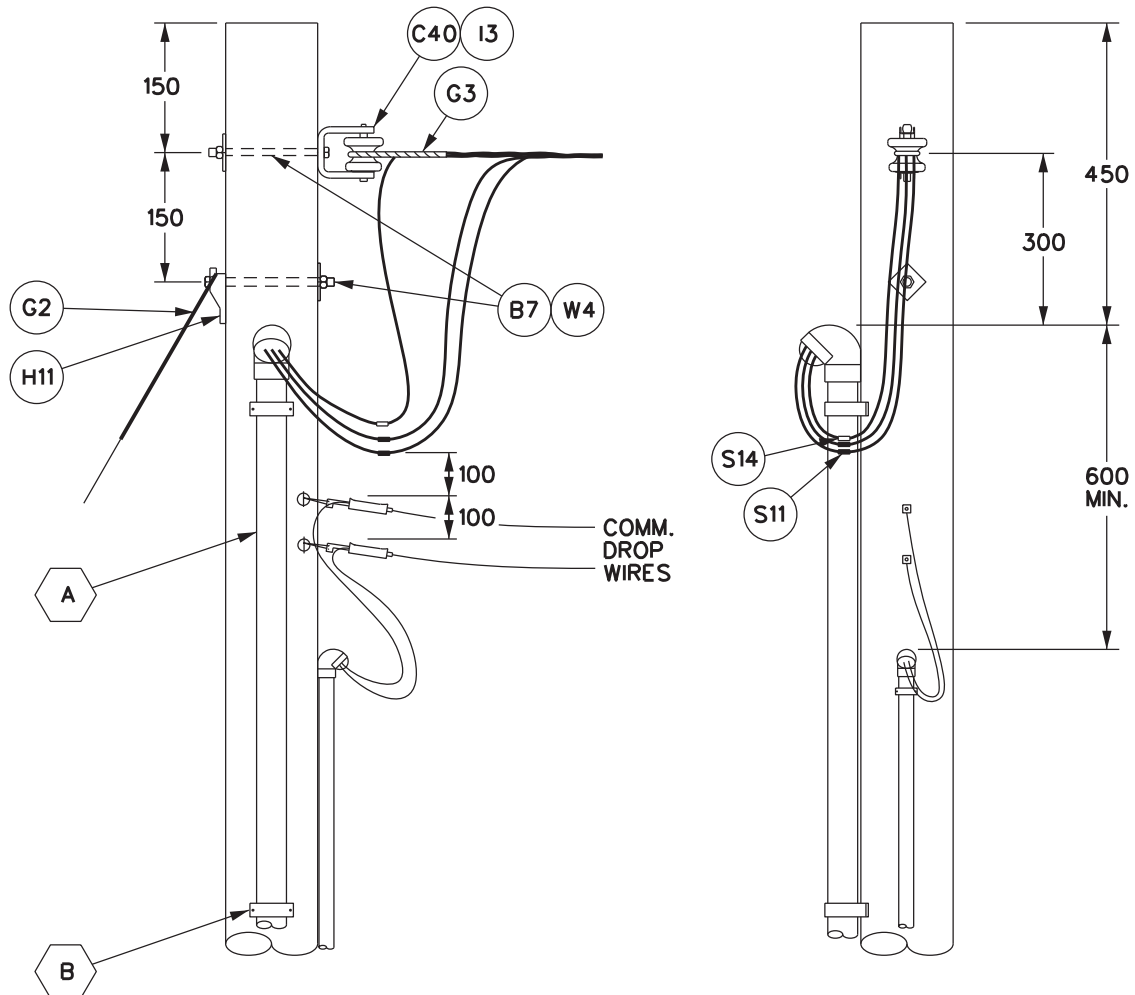

NOTES:

- A. TECK CABLE MAY BE USED INSTEAD OF CONDUIT, BUT STILL REQUIRES A WEATHERHEAD.
- B. STRAP CONDUIT OR TECK CABLE TO THE POLE EVERY 1200 MAXIMUM.
- C. ALL DIMENSIONS ARE IN MILLIMETERS UNLESS OTHERWISE SHOWN.

NSPI & BELL CANADA JOINT-USE DISTRIBUTION STANDARDS

JOINT-USE UNDERGROUND SERVICE POLE

Jim McFadgen P. Eng.

FOR NSPI;
JIM MCFADGEN, P.ENG

Stephen Cumming

FOR BELL;
STEPHEN CUMMING, P.ENG

DRAWN: M.HALASZ

REV DATE: 2021-12-13

STD NO: **J-ED-34M**

SHT: 1 OF 1

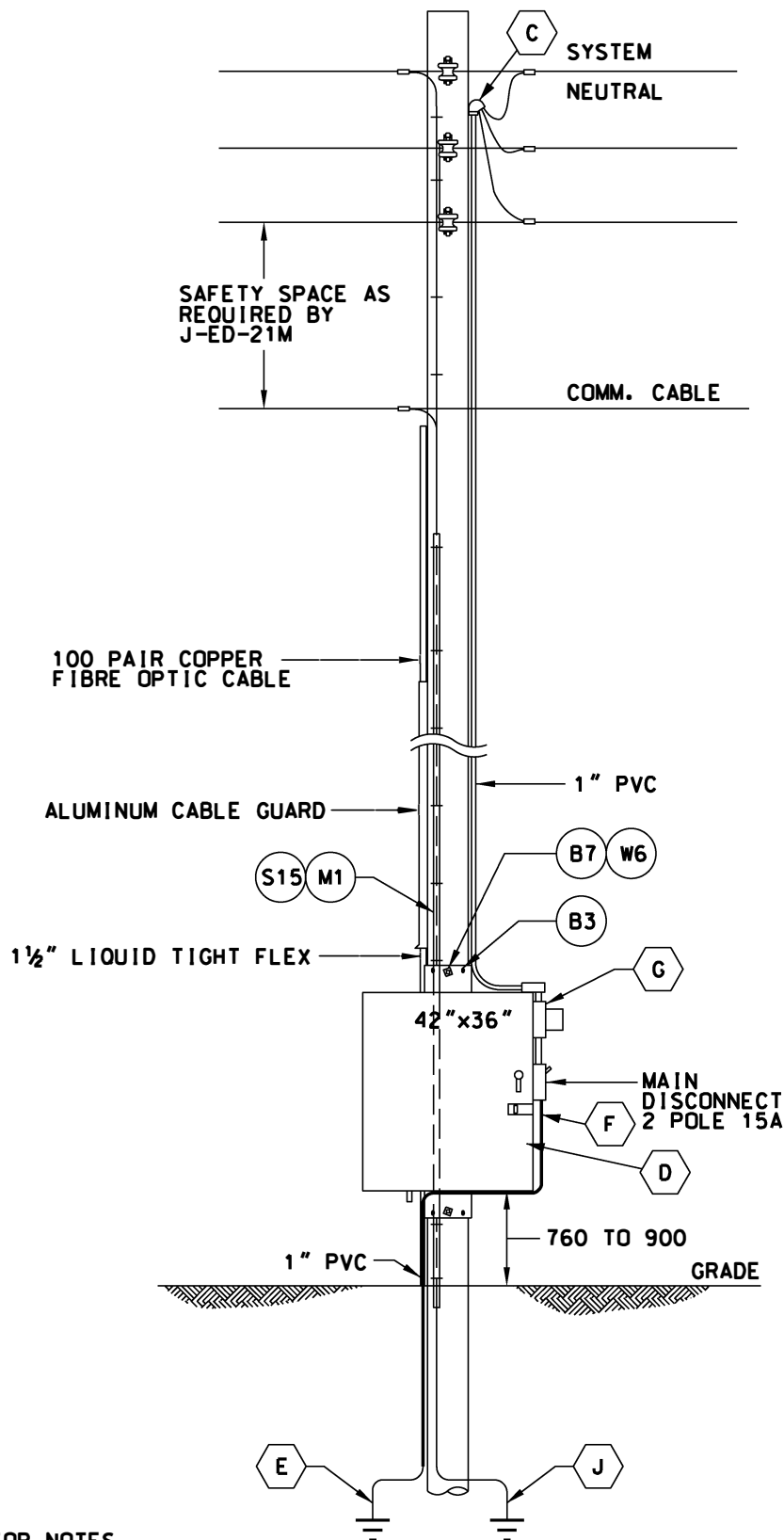

NOTES:
SEE SHEET 2 OF 2 FOR NOTES.

NSPI & BELL CANADA JOINT-USE DISTRIBUTION STANDARDS

JOINT-USE FRAMING POLE MOUNTED CABINET WITH POWER METER BASE

Jim McFadgen P. Eng.
FOR NSPI;
JIM MCFADGEN, P.ENG

Stephen Cumming
FOR BELL;
STEPHEN CUMMING, P.ENG

DRAWN:	M.HALASZ
REV DATE:	2022-05-20
STD NO:	J-ED-36M
SHT:	1 OF 2

NOTES:

- A. NSP SERVICES SAFE CLEARANCE REPORT SHALL BE ISSUED FOR ALL INSTALLATIONS.
- B. POLE MOUNT CABINET PLACEMENT GUIDELINES:
 - a) POLE SHOULD BE STRUCTURALLY SOUND. THE POLE SHOULD NOT HAVE MAJOR IMPAIRMENTS SUCH AS DEEP CRACKS, SPLITS, PHYSICAL DAMAGE FROM VEHICLES OR FIRE. POLE SHOULD HAVE ADEQUATE JOINT USE SEPARATION AND MINIMUM STANDARD GROUND CLEARANCES.
 - b) ENSURE GROUND AT BASE OF CABINET IS LEVEL AND UNOBSTRUCTED. MOUNTING HEIGHT IS 900mm TO BOTTOM OF CABINET. INSTALL CABINETS 700mm TO 900mm FROM GROUND LEVEL. THE HEIGHT OF THE METER INSTALLED ON CABINET IS REQUIRED TO BE BETWEEN 1400mm AND 1800mm.
 - c) NOT TO BE INSTALLED ON POLES WITH A 3-PHASE GANG-OPERATED SWITCH, UTILITY CONTROL CABINET, 3 PHASE TAKE-OFF POLE, OR ANY POLE IN WHICH POWER UTILITY WORK COULD BE IMPEDED.
 - d) MOUNTING BOLTS ARE TO BE CUT OFF WITH A MAXIMUM OF 12mm (0.5in) EXPOSED THREAD PAST THE NUT AND TREATED WITH COLD GALVANIZED PAINT TO PREVENT CORROSION.
 - e) SEAL LIQUID TIGHT CONDUITS USED TO CONVEY COMMUNICATION CABLES AND DRILL 1.6mm (0.063IN) DRAIN HOLE AT BOTTOM OF SWEEP BEND.
 - f) THERE MAY NOT BE MORE THAN ONE SERVICE ENTRANCE GROUND ELECTRODE AT THE BASE OF EACH POLE. THIS LIMITS THE NUMBER OF POWERED DEVICES OF ANY TYPE TO ONE PER POLE.
 - g) EXCEPTIONS TO THE ABOVE MUST BE APPROVED BY BOTH NSPI AND BELL ENGINEERING.
- C. WEATHERHEAD SHALL BE 400mm BELOW NEUTRAL LINE WHEN NO SECONDARY CONDUCTOR(S) ARE PRESENT.
- D. IF CABINET IS PLACED ON A POLE WITH AN EXISTING CABINET, ACCESS IS TO BE PROVIDED FOR A MAN-LIFT TRUCK TO ENABLE UTILITY WORKERS TO PERFORM WORK SAFELY.
- E. THE SERVICE GROUND IS REQUIRED SEPARATELY FROM THE NSPI SYSTEM GROUND ON ALL INSTALLATIONS AS PER CANADIAN ELECTRICAL CODE, PART 1.
- F. #6AWG INSULATED COPPER GROUND CONDUCTOR SHALL HAVE A CONTINUOUS RUN FROM MAIN DISCONNECT.
- G. 100AMP METER BASE, IF PRESENT, HEIGHT TO THE CENTER OF THE METER BASE TO BE BETWEEN 1400mm TO 1800mm. IF NO METER BASE IS PRESENT THE TOP OF THE CABINET SHALL BE BETWEEN 1400mm AND 1800mm.
- H. ALL LOCATIONS SHALL BE JOINTLY SCOPED BY NSPI AND THE COMMUNICATION COMPANY INVOLVED.
- I. ALL METALLIC ENCLOSURES SHALL BE BONDED TO GROUND. CASE GROUNDS FOR THE MICROCELL AND ALL EXISTING STRANDS ARE TO BE BONDED TO THE NSPI DOWN GROUND.
- J. IF THERE IS NO NSPI SYSTEM GROUND ON THE POLE, THEN ONE MUST BE INSTALLED AS REQUIRED BY NSPI STANDARD J-ED-13M.
- K. ALL DIMENSIONS ARE IN MILLIMETERS UNLESS OTHERWISE SHOWN.

NSPI & BELL CANADA JOINT-USE DISTRIBUTION STANDARDS

JOINT-USE FRAMING POLE MOUNTED CABINET WITH POWER METER BASE

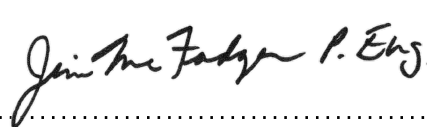
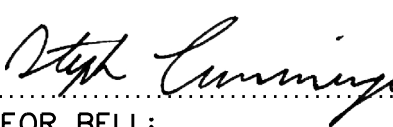
 FOR NSPI; JIM MCFADGEN, P.ENG	 FOR BELL; STEPHEN CUMMING, P.ENG	DRAWN: M.HALASZ	
		REV DATE: 2022-05-20	
		STD NO: J-ED-36M	
		SHT: 2 OF 2	

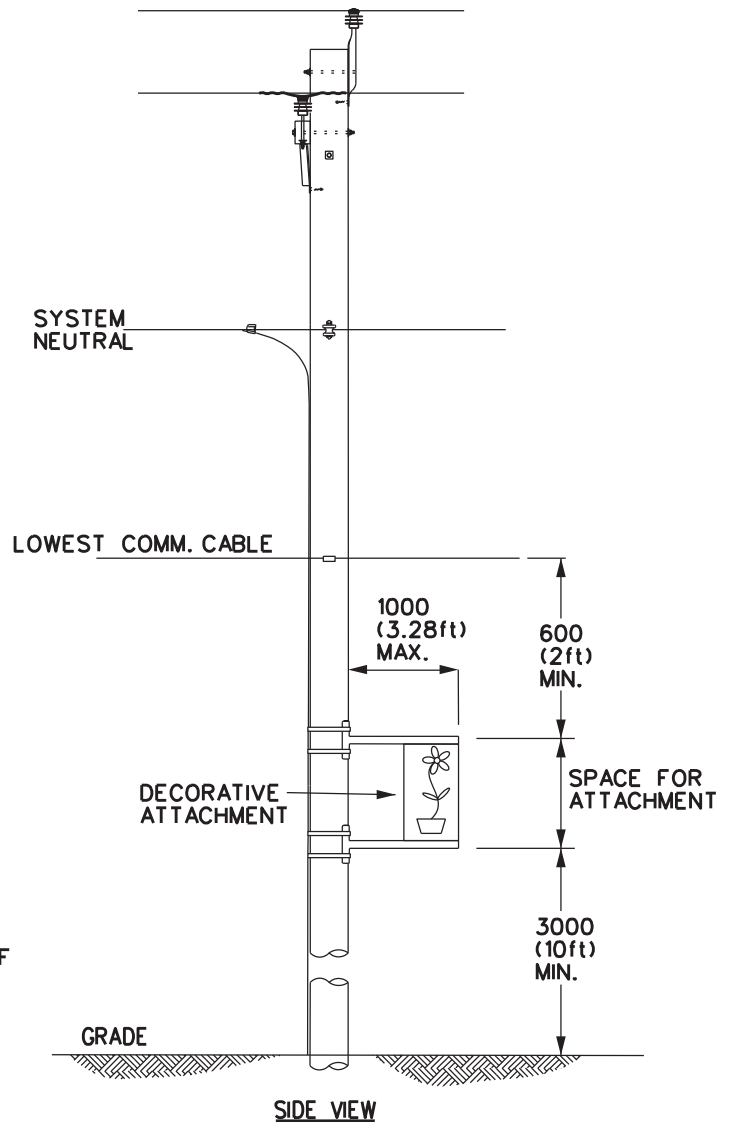
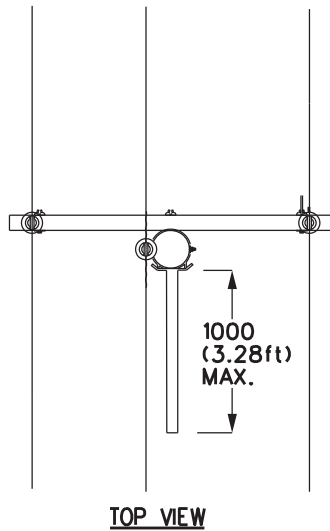



NOTES:

- A. ALL CLEARANCES SHOWN ARE MINIMUMS. DECORATIVE ATTACHMENTS MAY BE ANY SIZE THAT DOES NOT CAUSE A VIOLATION OF ONE OF THE MINIMUM CLEARANCES SHOWN OR QUOTED.
- B. THE PREFERRED ORIENTATION OF THE DECORATIVE ATTACHMENT IS PARALLEL TO THE CABLES AS SHOWN IN THE SKETCH
- C. IF THE DECORATIVE ATTACHMENT IS TO BE INSTALLED SUCH THAT THE BRACKET IS PERPENDICULAR TO THE CABLES, REFER TO SHEET 3 OF 3 FOR NOTES AND DETAILS.
- D. OWNER OF THE DECORATIVE ATTACHMENT IS RESPONSIBLE TO ENSURE THAT THE METHOD OF ATTACHMENT IS SUFFICIENT TO SUPPORT THE ATTACHMENT.
- E. BANDING OF THE ATTACHMENT TO POLES IS PREFERRED (STAINLESS STEEL BANDS). MINIMUM WIDTH OF THE BANDS IS TO BE 25mm (1INCH). BANDS MUST NOT BE APPLIED OVER CONDUITS, CABLES OR GROUND WIRES.
- F. ATTACHMENT WITH GALVANIZED LAG SCREWS NOT MORE THAN 75mm (3 INCHES) LONG IS ACCEPTABLE. ACCEPTANCE STANDARD FOR LAG SCREW IS HUBBEL POWER SYSTEMS PART NUMBER DFL250 OR UTILITY APPROVED EQUIVALENT (THIS IS 3/8 INCH BY 2 1/2 INCH LONG LAG SCREW).
- G. THE MAXIMUM WEIGHT OF ANY DECORATIVE ATTACHMENT SHALL BE 22.7 KG (50lbs).
- H. NO DECORATIVE ATTACHMENTS ARE PERMITTED THAT ARE CONNECTED TO TWO POLES AT ONCE. E.G. - NO BANNERS THAT SPAN A ROADWAY.
- I. THIS DRAWING APPLIES TO NON-POWERED DECORATIVE ATTACHMENTS ONLY.
- J. ALL DIMENSIONS ARE IN MILLIMETERS UNLESS OTHERWISE SHOWN.

NSPI & BELL CANADA JOINT-USE DISTRIBUTION STANDARDS

DECORATIVE ATTACHMENT POLE HANGING BANNER ON JOINT USE POLE

 FOR NSPI; JIM MCFADGEN, P.ENG	 FOR BELL; STEPHEN CUMMING, P.ENG	DRAWN: M.HALASZ REV DATE: 2021-12-13 STD NO: J-ED-37M SHT: 1 OF 3
---	---	---

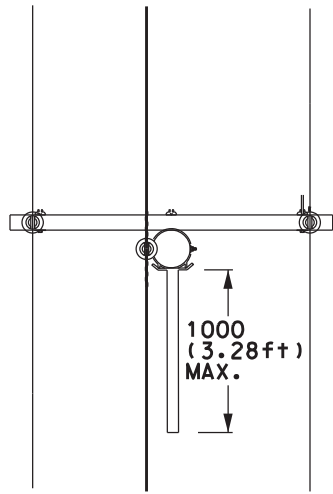

TOP VIEW

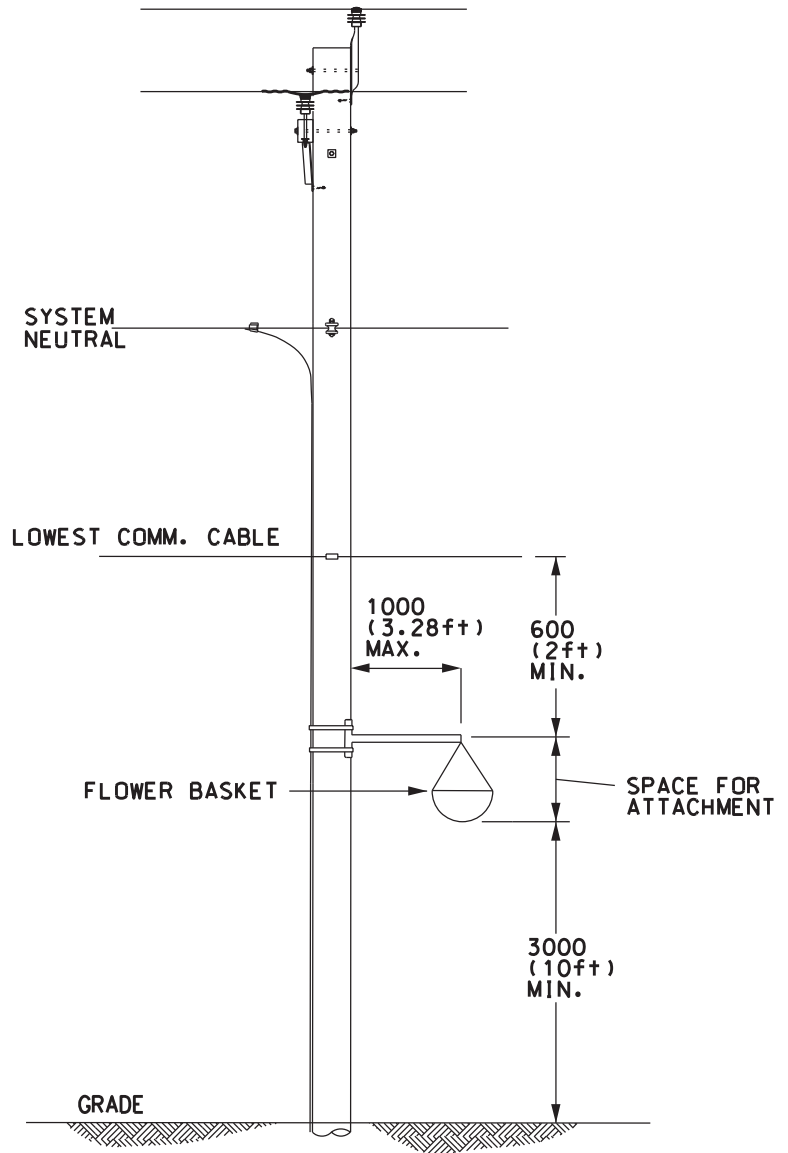

NOTES:

- A. ALL CLEARANCES SHOWN ARE MINIMUMS. DECORATIVE ATTACHMENTS MAY BE ANY SIZE THAT DOES NOT CAUSE A VIOLATION OF ONE OF THE MINIMUM CLEARANCES SHOWN OR QUOTED.
- B. THE PREFERRED ORIENTATION OF THE DECORATIVE ATTACHMENT IS PARALLEL TO THE CABLES AS SHOWN IN THE SKETCH
- C. IF THE DECORATIVE ATTACHMENT IS TO BE INSTALLED SUCH THAT THE BRACKET IS PERPENDICULAR TO THE CABLES, REFER TO SHEET 3 OF 3 FOR NOTES AND DETAILS.
- D. OWNER OF THE DECORATIVE ATTACHMENT IS RESPONSIBLE TO ENSURE THAT THE METHOD OF ATTACHMENT IS SUFFICIENT TO SUPPORT THE ATTACHMENT.
- E. BANDING OF THE ATTACHMENT TO POLES IS PREFERRED (STAINLESS STEEL BANDS). MINIMUM WIDTH OF THE BANDS IS TO BE 25mm (1 INCH). BANDS MUST NOT BE APPLIED OVER CONDUITS, CABLES OR GROUND WIRES.
- F. ATTACHMENT WITH GALVANIZED LAG SCREWS NOT MORE THAN 75mm (3 INCHES) LONG IS ACCEPTABLE. ACCEPTANCE STANDARD FOR LAG SCREW IS HUBBEL POWER SYSTEMS PART NUMBER DFL250 OR UTILITY APPROVED EQUIVALENT (THIS IS 3/8 INCH BY 2 1/2 INCH LONG LAG SCREW).
- G. THE MAXIMUM WEIGHT OF ANY DECORATIVE ATTACHMENT SHALL BE 22.7 KG (50lbs).
- H. NO DECORATIVE ATTACHMENTS ARE PERMITTED THAT ARE CONNECTED TO TWO POLES AT ONCE. E.G. - NO BANNERS THAT SPAN A ROADWAY.
- I. THIS DRAWING APPLIES TO NON-POWERED DECORATIVE ATTACHMENTS ONLY.
- J. ALL DIMENSIONS ARE IN MILLIMETERS UNLESS OTHERWISE SHOWN.

NSPI & BELL CANADA JOINT-USE DISTRIBUTION STANDARDS

DECORATIVE ATTACHMENT POLE HANGING FLOWER BASKET ON JOINT USE POLE

 FOR NSPI; JIM MCFADGEN, P.ENG	 FOR BELL; STEPHEN CUMMING, P.ENG	DRAWN: M.HALASZ
		REV DATE: 2021-12-13
		STD NO: J-ED-37M
		SHT: 2 OF 3

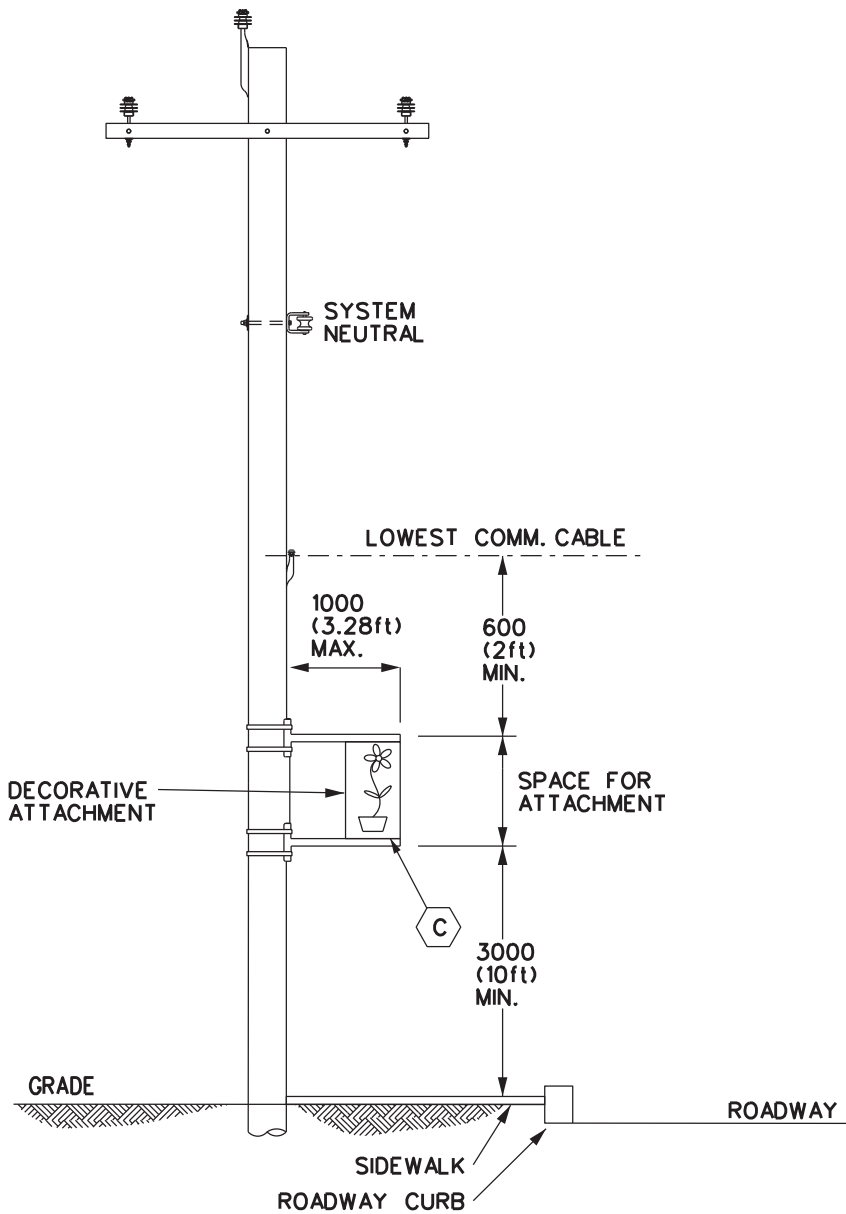



NOTES:

- A. IF THE DECORATIVE ATTACHMENT IS TO BE INSTALLED SUCH THAT THE BRACKET IS PERPENDICULAR TO THE CABLES, THEN THE FOLLOWING RESTRICTIONS APPLY:
- B. THE DECORATIVE ATTACHMENT MUST NOT PROTRUDE SUCH THAT THEY ARE LESS THAN 0.3m (1ft) AWAY FROM THE ROAD FACE OF A CURB (WHERE PRESENT).
- C. ATTACHMENT SHALL NOT TO EXTEND PAST THE ROADWAY FACE OF CURB OR SHOULDER OF THE ROAD. WHERE THERE IS NO CURB, THE ATTACHMENT MUST NOT PROTRUDE INTO THE TRAVELLED ROADWAY (INCLUDING THE SHOULDER).
- D. IF THE DECORATIVE ATTACHMENT PROJECTS OVER THE VEHICLE TRAVELLED SURFACE; THE MINIMUM HEIGHT FROM BOTTOM OF DECORATIVE ATTACHMENT TO THE GROUND MUST BE 4.57m (15ft).
- E. IF THE DECORATIVE ATTACHMENT IS ON THE SIDEWALK SIDE OF THE POLE, THE MINIMUM CLEARANCE OVER THE SIDEWALK MUST BE 3m (10ft) FOR THE LOWEST POINT ON THE ATTACHMENT.
- F. ALL DIMENSIONS ARE IN MILLIMETERS UNLESS OTHERWISE SHOWN.

NSPI & BELL CANADA JOINT-USE DISTRIBUTION STANDARDS

DECORATIVE ATTACHMENT POLE HANGING CLEARANCES ON JOINT USE POLE

 FOR NSPI; JIM MCFADGEN, P.ENG	 FOR BELL; STEPHEN CUMMING, P.ENG	DRAWN: M.HALASZ
		REV DATE: 2021-12-13
		STD NO: J-ED-37M
		SHT: 3 OF 3

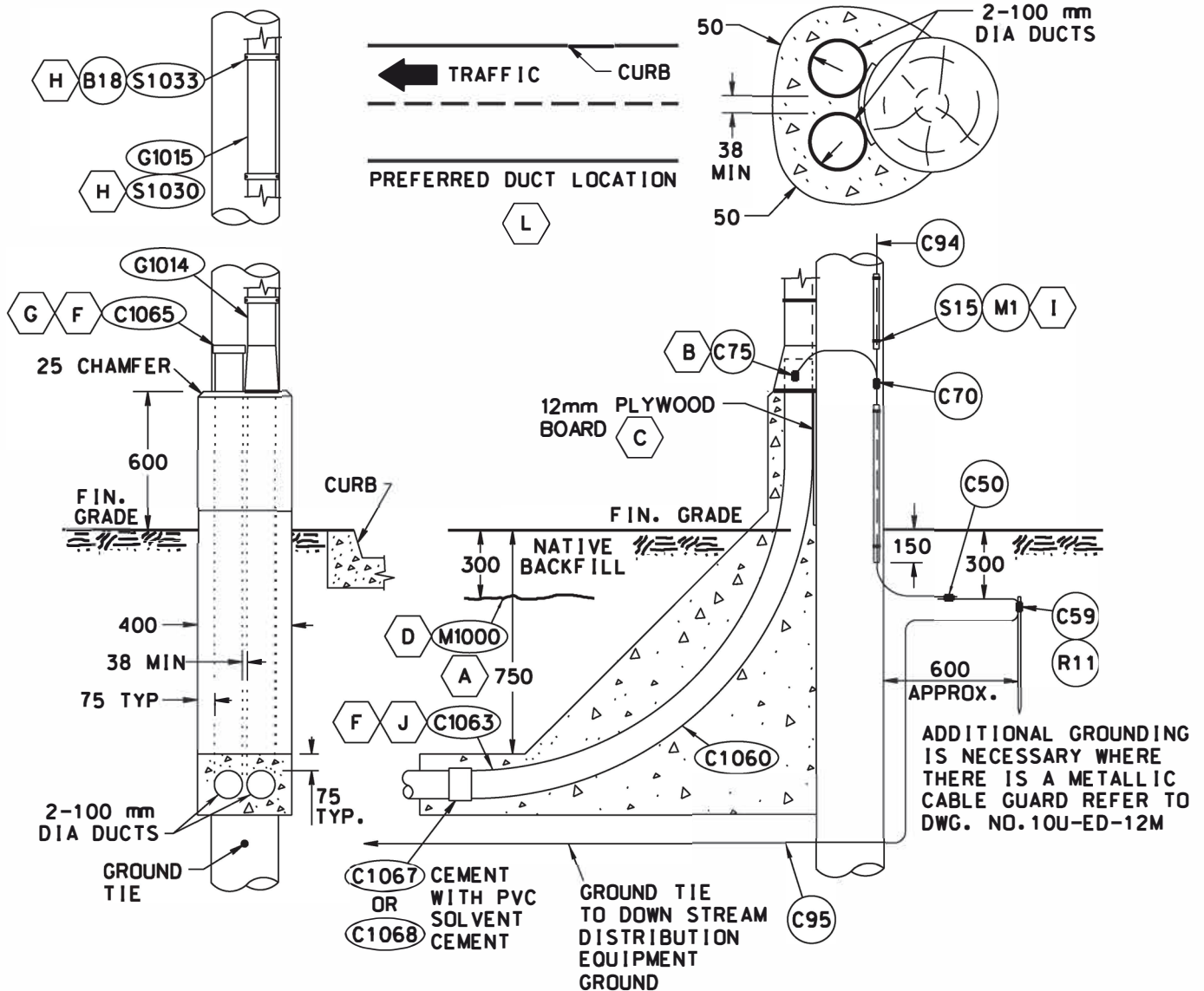

NOTES:

- A. REFER TO DWG. NO. 1U-ED-44M FOR ROADWAY/DRIVEWAY REQUIREMENTS.
- B. REFER TO DWG. NO. 10U-ED-12M FOR BONDING OF CABLE GUARDS.
- C. DUCTS SHALL BE SECURED TO THE POLE WITH CONDUIT STRAPS AND HAVE A 12 mm THICK PLYWOOD BOARD SPACER BEFORE CONCRETE IS POURED.
- D. DUCT RUNS SHALL BE FORMED BY THE CUSTOMER OR HIS AGENT AND INSPECTED BY NSPI REPRESENTATIVES PRIOR TO POURING OF THE CONCRETE. MARKER TAPE TO BE INSTALLED AS SHOWN.
- E. FOR JOINT USE DETAILS REFER TO DWG. NO. 1U-ED-14M.
- F. ALL DUCTS MUST BE SWABBED, THEN CAPPED FOR PROTECTION.
- G. ALL DUCTS SHALL HAVE A NYLON FISH LINE (ITEM N1000 INSTALLED PRIOR TO CAPPING.
- H. STRAP CABLES UNDER GUARD EVERY 3000 mm AND CABLE GUARD TO POLE EVERY 1200 mm.
- I. STAPLED GROUND WIRE MOULDINGS TO POLE EVERY 1200 mm.
- J. 100 mm DUCTS SHALL NORMALLY BE USED. IN SPECIAL CIRCUMSTANCES WHEN MORE THAN THREE 90 BENDS ARE NEEDED BETWEEN CABLE PULLING POINTS, OR DUCT RUN EXCEEDS 92 m. 125 mm DUCTS SHALL BE USED.
- K. FOR TERMINATION DETAILS REFER TO DWG. NO.'S 5U-ED 11M TO 5U-ED-13M.
- L. DUCTS SHALL NOT BE INSTALLED ON THE CURB OR TRAFFIC SIDES OF THE POLE.

(SAME AS 5U-ED-10M)



DISTRIBUTION STANDARDS



DUCT TERMINATION AT POLE FOR UNDERGROUND PRIMARY SERVICE

DATE:	2008-08-14	REV DATE:	2016-04-12
DRAWN:	M. HALASZ	STD NO:	OU-ED-10M
APPROVED:	J. A. MCFADGEN	SHT NO:	1 OF 1 (R2)

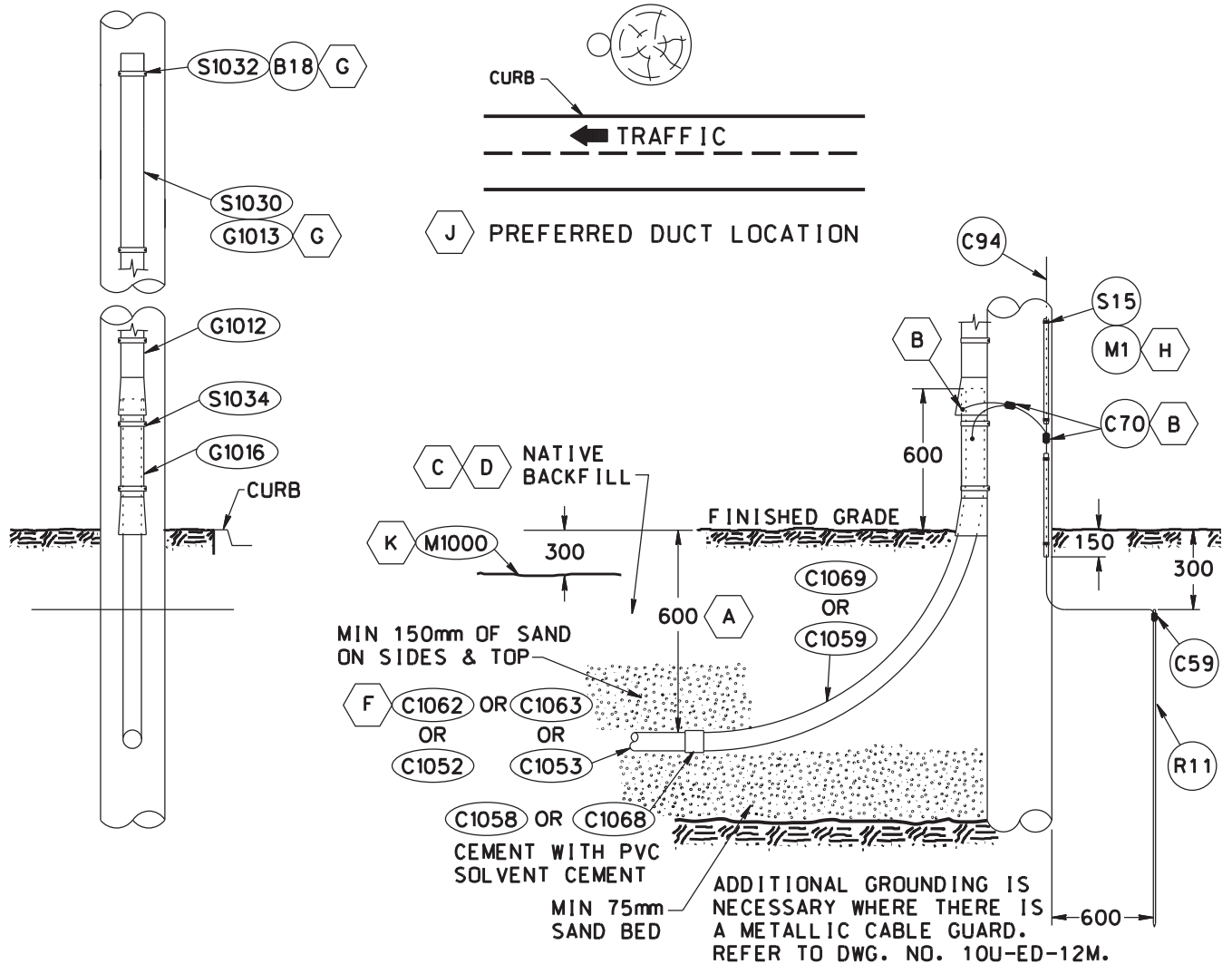

NOTES:

- A. MINIMUM COVER REQUIREMENTS FOR DIRECT BURIED CONDUIT IN VEHICULAR AREAS IS 1000mm.
- B. FOR BONDING OF CABLE GUARDS, REFER TO DWG. NO. 10U-ED-12M.
- C. NATIVE BACKFILL MATERIAL SHALL NOT CONTAIN ROCKS OVER 50mm IN DIAMETER FOR THE FIRST 300mm ABOVE CONDUIT.
- D. BACKFILL SHALL BE COMPACTED EVERY 300mm MINIMUM.
- E. FOR JOINT USE DETAILS, REFER TO DWG. NO. 1U-ED-25M.
- F. ALL CONDUIT MUST BE CLEANED, HAVE NYLON FISH LINE (ITEM N1000) INSTALLED, AND THEN CAPPED FOR PROTECTION.
- G. STRAP CABLE TO THE POLE EVERY 3000mm AND THE CABLE GUARD TO THE POLE EVERY 1200mm.
- H. STAPLE GROUND WIRE MOULDING TO THE POLE EVERY 600mm.
- I. CONDUIT RUNS SHALL BE CONSTRUCTED BY THE CUSTOMER OR HIS AGENT AND BE INSPECTED BY NSPI REPRESENTATIVES PRIOR TO BACKFILLING.
- J. THE CONDUIT SHALL NOT BE INSTALLED ON THE CURB OR TRAFFIC SIDE OF THE POLE.
- K. MARKER TAPE (ITEM M1000) SHALL BE INSTALLED ABOVE THE CONDUIT FOR ITS ENTIRE LENGTH, AS SHOWN.
- L. NOT APPLICABLE TO CUSTOMER OWNED SERVICE ENTRANCE.

(SAME AS 5U-ED-20M)



DISTRIBUTION STANDARDS



**CONDUIT TERMINATION AT POLE FOR UNDERGROUND SERVICES
(URD SUPPLY, 750 VOLTS AND LESS)**

DATE:	2008-08-14	REV DATE:	2018-05-29
DRAWN:	M. HALASZ	STD NO:	OU-ED-20M
APPROVED:	J. A. MCFADGEN	SHT NO:	1 OF 1 (R3)

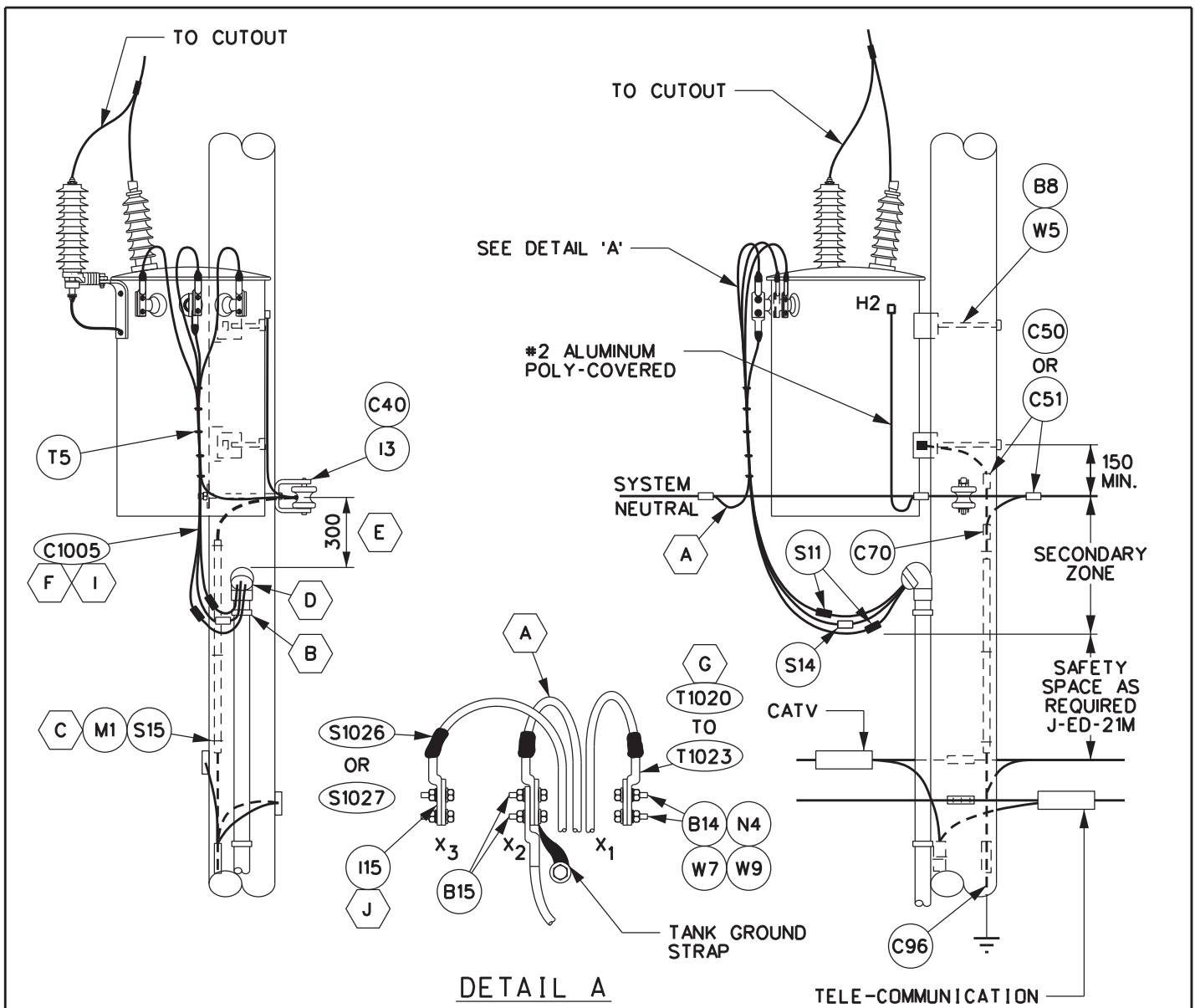

NOTES:

- A. MINIMUM #1/0 ALUMINUM POLY-COVERED CONDUCTOR SHALL BE USED FOR X2 BOND TO SYSTEM NEUTRAL.
- B. PVC CONDUIT TO BE STRAPPED TO POLE EVERY 1200 mm.
- C. GROUND WIRE MOULDING TO BE STAPLED TO POLE EVERY 600 mm.
- D. THE CUSTOMER IS RESPONSIBLE FOR SUPPLYING AND INSTALLING THE SERVICE HEAD, CABLE AND RIGID PVC CONDUIT.
- E. TOP SERVICE HEAD TO BE LOCATED 300 BELOW SYSTEM NEUTRAL.
- F. FOR CABLE DATA REFER TO SECTION "3U".
- G. FOR TERMINAL INSTALLATION DETAILS REFER TO SECTION '4U' OF THE U/G STANDARDS MANUAL.
- H. FOR CONDUIT TERMINATION DETAILS REFER TO DWG. OU-ED-20M.
- I. MINIMUM LENGTH OF SECONDARY CABLE AS MEASURED FROM WEATHERHEAD TO END OF CONDUCTOR FOR MAKING CONNECTIONS AND FORMING DRIP LOOP SHALL BE 1.5 m WHEN CONNECTING DIRECTLY TO THE TRANSFORMER TERMINALS AND 1.0 m WHEN CONNECTING DIRECTLY TO THE SECONDARY CONDUCTORS.
- J. USE AN APPROVED INHIBITOR WHEN THE TRANSFORMER TERMINAL IS OF DISIMILAR MATERIAL THAN THE CONDUCTOR TERMINAL.
- K. ALL DIMENSIONS ARE IN MILLIMETERS UNLESS OTHERWISE NOTED.

(SAME AS 5U-ED-22M)

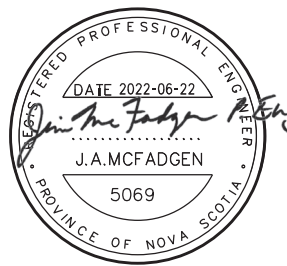

DISTRIBUTION STANDARDS



**OVERHEAD TRANSFORMER TERMINATION DETAILS
UNDERGROUND SERVICE DIRECTLY TO A CUSTOMER**

DATE:	2008-10-20	REV DATE:	2022-06-22
DRAWN:	M. HALASZ	STD NO:	OU-ED-22M
APPROVED:	J. A. MCFADGEN	SHT NO:	1 OF 1 (R3)

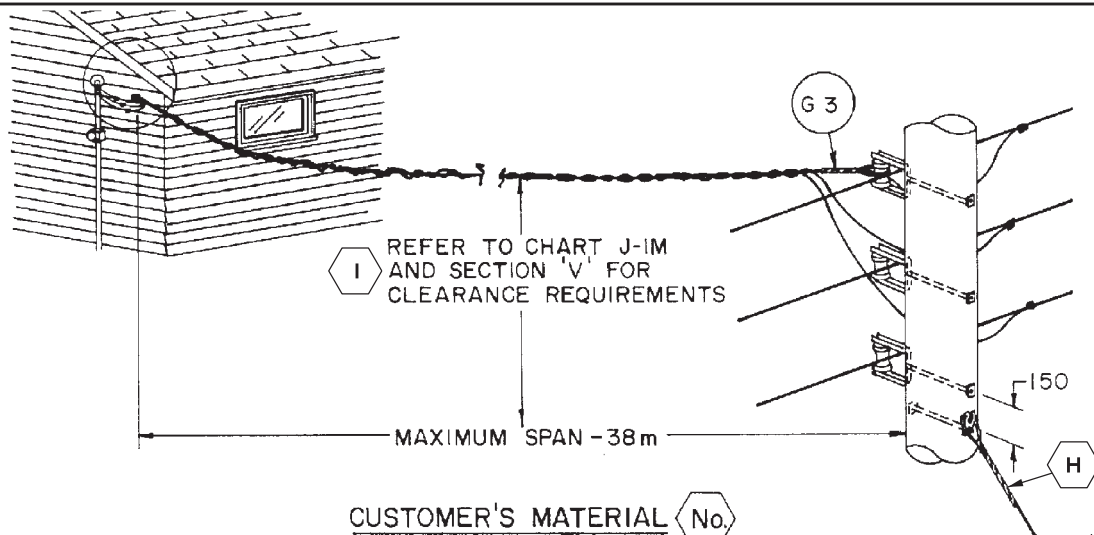

CUSTOMER'S MATERIAL No.

1. SERVICE HEAD
2. SERVICE ENTRANCE CONDUCTOR, INSULATED
3. RIGID CONDUIT
4. METER BASE

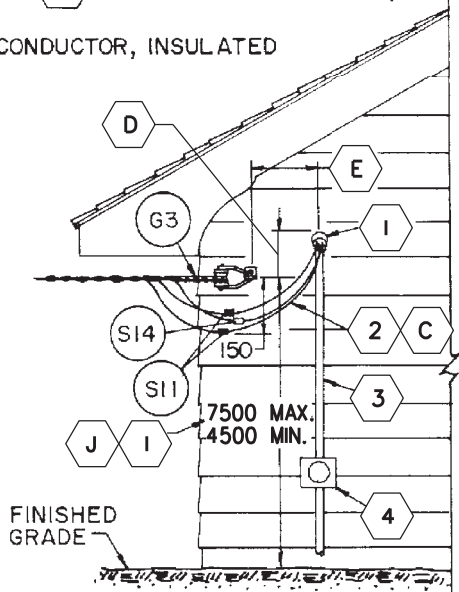
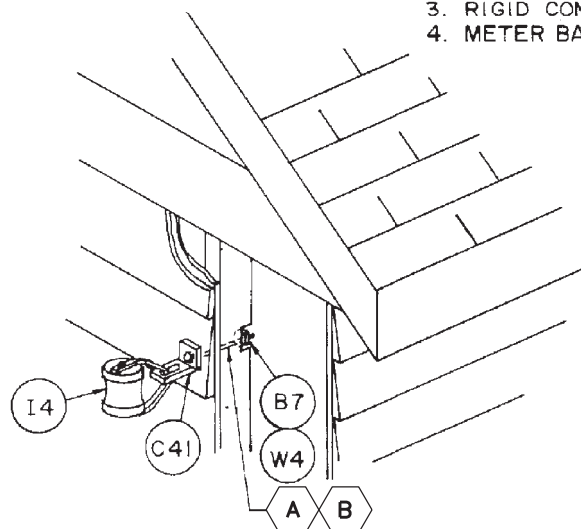

NOTES:

- A. THE CUSTOMER SHALL BE RESPONSIBLE FOR INSTALLING THE SERVICE ATTACHMENT DEVICE TO THE BUILDING AT THE TIME OF CONSTRUCTION AND ENSURING THE ATTACHMENT WILL SUPPORT A HORIZONTAL LOAD OF 3kN IN ANY DIRECTION.
- B. MATERIAL REQUIRED FOR SERVICE ATTACHMENT SHALL BE SUPPLIED BY NSPI.
- C. CUSTOMER'S SERVICE ENTRANCE CONDUCTORS SHALL EACH EXTEND NOT LESS THAN 1000 BEYOND THE SERVICE HEAD TO ALLOW FOR UTILITY CONNECTIONS.
- D. SERVICE ATTACHMENT SHALL BE INSTALLED A MINIMUM OF 150 MIN AND 300 MAX BELOW THE SERVICE HEAD.
- E. SERVICE ATTACHMENT SHALL BE INSTALLED A MINIMUM OF 150 MIN AND 300 MAX HORIZONTAL DISTANCE FROM THE SERVICE HEAD.
- F. 150 DRIP LOOP TO BE LEFT AT THE POLE AND HOUSE CONNECTION.
- G. REFER TO CHART SS-1M FOR RECOMMENDED SIZES OF TRIPLEX CABLE TO BE USED.
- H. ANCHORING AND GUYING TO BE IN ACCORDANCE WITH SECTION 'A'.
- I. AT THE DISCRETION OF FIELD ENGINEER, OR THEIR REPRESENTATIVE, MINIMUM SERVICE ATTACHMENT HEIGHT MAY BE INCREASED OR DECREASED TO MEET CLEARANCE REQUIREMENTS UNDER MAXIMUM SAG CONDITIONS AS SPECIFIED IN CHART J-1M AND SECTION "V".
- J. THE MAXIMUM SERVICE MAST HEIGHT IS MEASURED FROM LEVEL GROUND. THIS REQUIREMENT MAY BE WAIVED, WITH THE APPROVAL OF NSPI, IF THE SERVICE IS REACHABLE WITH A BOOM TRUCK FROM THE DRIVEWAY.
- K. ALL DIMENSIONS ARE IN MILLIMETERS UNLESS OTHERWISE SHOWN.



DISTRIBUTION STANDARDS



**TRIPLEX SERVICE CONNECTION FOR SINGLE DWELLING
(NEW CONSTRUCTION - WALL ATTACHMENT)
120/240V (400A OR LESS)**

DATE:	2007-05-07	REV DATE:	2022-02-16
DRAWN:	M. HALASZ	STD NO:	SS-ED-10M
APPROVED:	J. A. MCFADGEN	SHT NO:	1 OF 1 (R4)

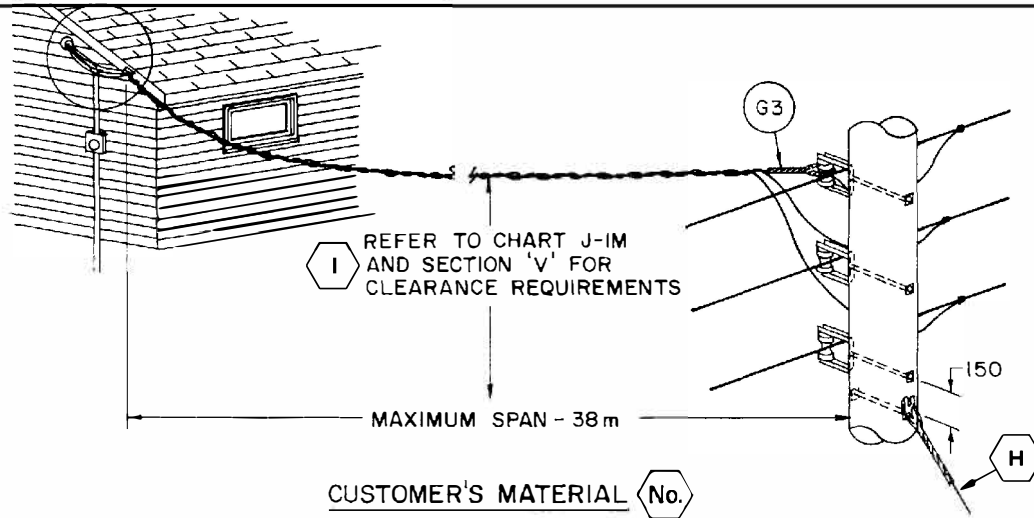

CUSTOMER'S MATERIAL (No.)

1. SERVICE HEAD
2. SERVICE ENTRANCE CONDUCTOR, INSULATED
3. RIGID CONDUIT
4. METER BASE

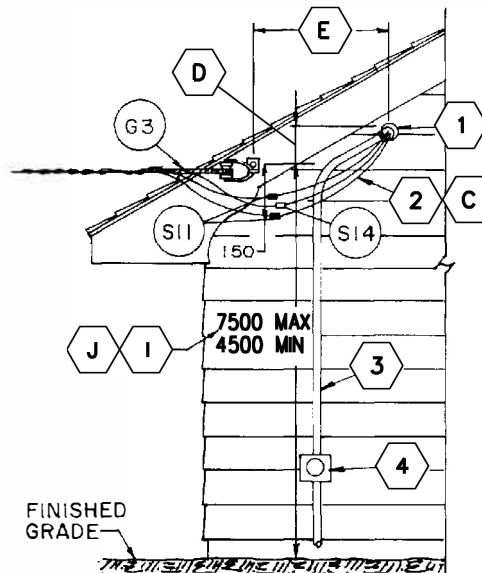
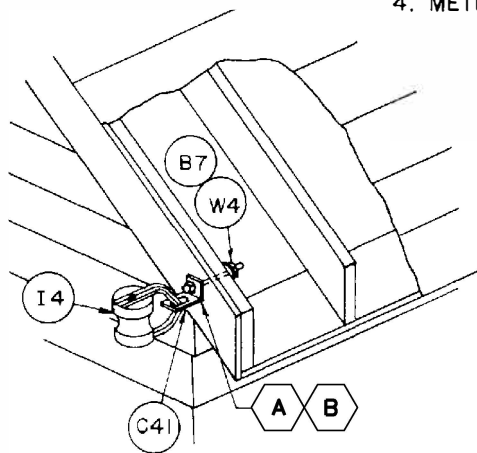

NOTES:

- A. THE CUSTOMER SHALL BE RESPONSIBLE FOR INSTALLING THE SERVICE ATTACHMENT DEVICE TO THE BUILDING AT THE TIME OF CONSTRUCTION AND ENSURING THE ATTACHMENT WILL SUPPORT A HORIZONTAL LOAD OF 3kN.
- B. MATERIAL REQUIRED FOR SERVICE ATTACHMENT SHALL BE SUPPLIED BY NSPI.
- C. CUSTOMER'S SERVICE ENTRANCE CONDUCTORS SHALL EACH EXTEND NOT LESS THAN 1000 BEYOND THE SERVICE HEAD TO ALLOW FOR UTILITY CONNECTIONS.
- D. SERVICE ATTACHMENT SHALL BE INSTALLED A 150 MIN AND 300 MAX BELOW THE SERVICE HEAD.
- E. SERVICE ATTACHMENT SHALL BE INSTALLED A 150 MIN AND 300 MAX HORIZONTAL DISTANCE FROM THE SERVICE HEAD. THE MAXIMUM MAY BE INCREASED TO 500MM FOR UNDER EAVE INSTALLATIONS.
- F. 150 DRIP LOOP TO BE LEFT AT THE POLE AND HOUSE CONNECTION.
- G. REFER TO CHART SS-1M FOR RECOMMENDED SIZES OF TRIPLE CABLE TO BE USED.
- H. ANCHORING AND GUYING TO BE IN ACCORDANCE WITH SECTION 'A'.
- I. AT THE DISCRETION OF THE FIELD ENGINEER, OR THEIR REPRESENTATIVE, MINIMUM SERVICE ATTACHMENT HEIGHT MAY BE INCREASED OR DECREASED TO MEET CLEARANCE REQUIREMENTS UNDER MAXIMUM SAG CONDITIONS AS SPECIFIED IN CHART J-1M AND SECTION 'V'.
- J. THE MAXIMUM SERVICE MAST HEIGHT IS MEASURED FROM LEVEL GROUND THIS REQUIREMENT MAY BE WAIVED, WITH THE APPROVAL OF NSPI, IF THE SERVICE IS REACHABLE WITH BOOM TRUCK FROM THE DRIVEWAY.
- K. ALL DIMENSIONS ARE IN MILLIMETERS UNLESS OTHERWISE SHOWN.

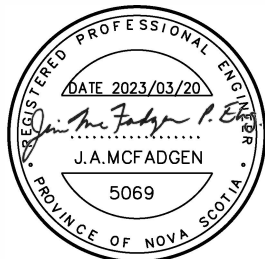

DISTRIBUTION STANDARDS



**TRIPLEX SERVICE CONNECTION
FOR SINGLE DWELLING (NEW CONSTRUCTION - EAVE ATTACHMENT)
120/240V (400A OR LESS)**

DATE:	2008-08-14	REV DATE:	2023-03-20
DRAWN:	M. HALASZ	STD NO:	SS-ED-11M
APPROVED:	J. A. MCFADGEN	SHT NO:	1 OF 1

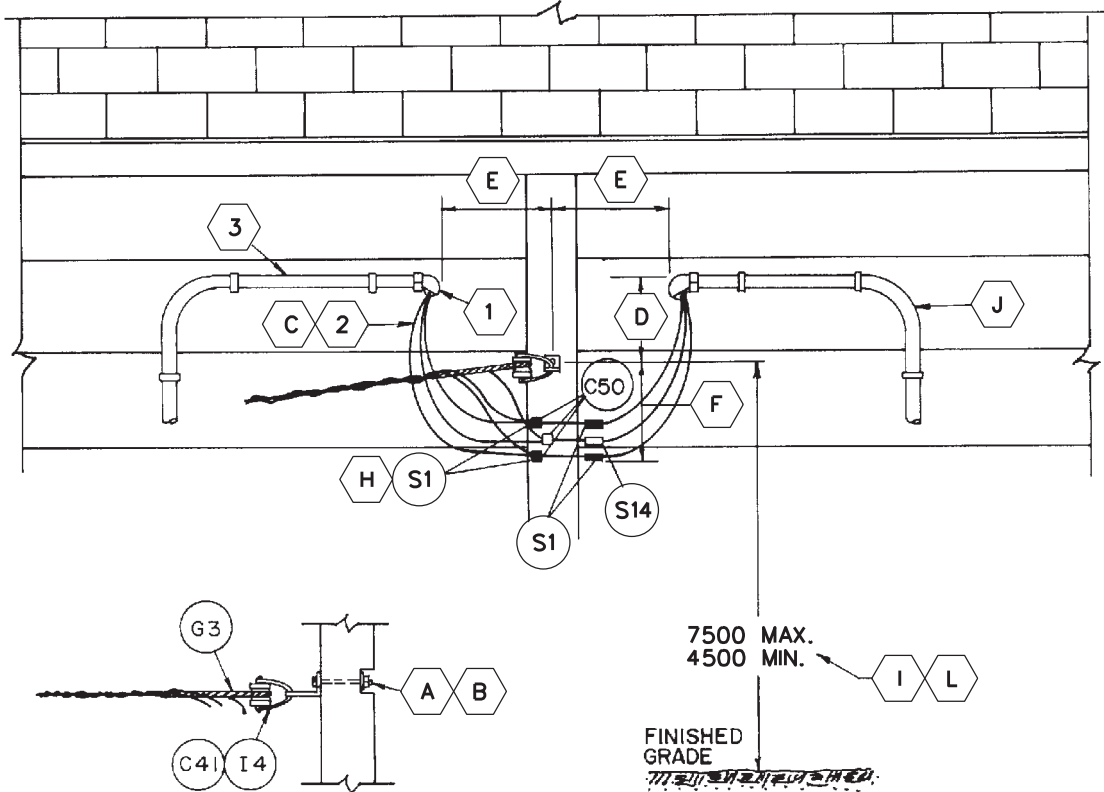

CUSTOMER'S MATERIAL (No.)

1. SERVICE HEAD
2. SERVICE ENTRANCE CONDUCTOR, INSULATED
3. RIGID CONDUIT
4. METER BASE

NOTES:

- A. THE CUSTOMER SHALL BE RESPONSIBLE INSTALLING THE SERVICE ATTACHMENT DEVICE TO THE BUILDING AT THE TIME OF CONSTRUCTION AND ENSURING THE ATTACHMENT WILL SUPPORT A HORIZONTAL LOAD OF 3kN.
- B. MATERIAL REQUIRED FOR SERVICE ATTACHMENT SHALL BE SUPPLIED BY NSPI.
- C. CUSTOMER'S SERVICE ENTRANCE CONDUCTORS SHALL EACH EXTEND NOT LESS THAN 1000 BEYOND THE SERVICE HEAD TO ALLOW FOR UTILITY CONNECTIONS.
- D. SERVICE ATTACHMENT SHALL BE INSTALLED 150 MIN AND 300 MAX BELOW THE SERVICE HEAD.
- E. SERVICE ATTACHMENT SHALL BE INSTALLED 150 MIN AND 300 MAX HORIZONTAL DISTANCE FROM THE SERVICE HEAD.
- F. 150 DRIP LOOP TO BE LEFT AT THE POLE AND HOUSE CONNECTION.
- G. REFER TO CHART SS-1M FOR RECOMMENDED SIZES OF TRIPLEX CABLE TO BE USED.
- H. SEALING COMPOUND SHALL BE APPLIED TO PHASE CONNECTIONS. NEUTRAL CONNECTIONS SHALL BE BARE.
- I. AT THE DISCRETION OF FIELD ENGINEERING, OR THEIR REPRESENTATIVE, MINIMUM SERVICE ATTACHMENT HEIGHT MAY BE INCREASED OR DECREASED TO MEET CLEARANCE REQUIREMENTS UNDER MAXIMUM SAG CONDITIONS AS SPECIFIED IN CHART J-1M AND SECTION 'V'.
- J. THE RIGID CONDUIT MAY BE INSTALLED IN SUCH A MANNER AS TO LOCATE A METER AT EACH END OF THE STRUCTURE.
- K. A DUPLEX HOUSE MAY HAVE SEPARATE CUSTOMER SERVICE WEATHERHEADS AT EITHER END OF THE STRUCTURE. THIS WOULD REQUIRE SEPARATE UTILITY SERVICE CONDUCTOR INSTALLATIONS BUILT AS PER SS-ED-10M AND SS-ED-11M. AN ADDITIONAL CHARGE IS TO BE APPLIED IN THIS CONFIGURATION (THE COST OF THE SECOND SERVICE CABLE INSTALLATION).
- L. THE MAXIMUM SERVICE MAST HEIGHT IS MEASURED FROM LEVEL GROUND. THIS REQUIREMENT MAY BE WAIVED, WITH APPROVAL OF NSPI, IF THE SERVICE IS REACHABLE WITH A BOOM TRUCK FROM THE DRIVEWAY.
- M. ALL DIMENSIONS ARE IN MILLIMETERS UNLESS OTHERWISE SHOWN.

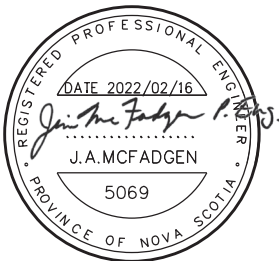

DISTRIBUTION STANDARDS



TRIPLEX SERVICE CONNECTION FOR DUPLEX HOUSE (NEW CONSTRUCTION) 120/240V

DATE:	2008-08-14	REV DATE:	2022-02-16
DRAWN:	M. HALASZ	STD NO:	SS-ED-12M
APPROVED:	J. A. MCFADGEN	SHT NO:	1 OF 1 (R4)

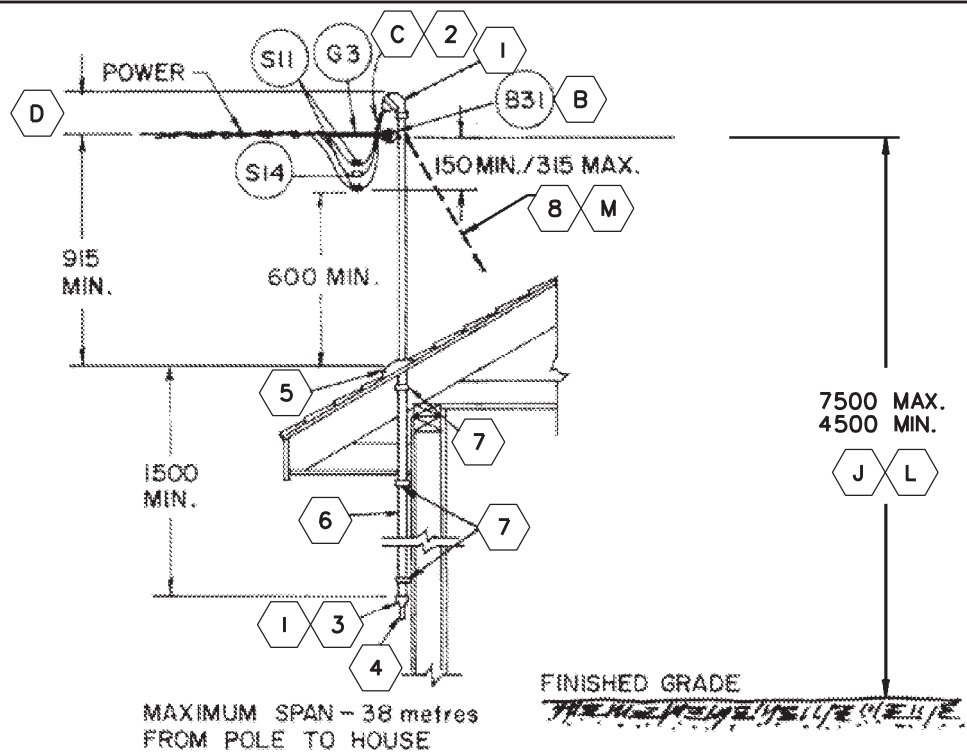

MAXIMUM SPAN - 38 metres
FROM POLE TO HOUSE

CUSTOMER'S MATERIAL (No.)

- | | |
|--|-------------------------------|
| 1. SERVICE HEAD | 6. MAST SUPPORT MEMBER |
| 2. SERVICE ENTRANCE CONDUCTOR, INSULATED | 7. SERVICE MAST CLAMP, GALV.. |
| 3. OFFSET CONDUIT REDUCER | 8. 6mm GALVANIZED STEEL WIRE |
| 4. RIGID CONDUIT | 9. METER BASE |
| 5. ROOF FLASHING | |

NOTES:

- A. THE CUSTOMER SHALL BE RESPONSIBLE FOR INSTALLING THE SERVICE BRACKET AND MAST IN A LOCATION SATISFACTORY TO BOTH THE INSPECTION DEPT. AND THE SUPPLY AUTHORITY, AND ENSURING THE ATTACHMENT SHALL BE SUPPLIED BY NSPI.
- B. MATERIAL REQUIRED FOR SERVICE ATTACHMENT SHALL BE SUPPLIED BY NSPI.
- C. CUSTOMER'S SERVICE ENTRANCE CONDUCTORS SHALL EACH EXTEND NOT LESS THAN 1000 BEYOND THE SERVICE HEAD TO ALLOW FOR UTILTIY CONNECTIONS.
- D. SERVICE ATTACHMENT SHALL BE INSTALLED 150 MIN AND 300 MAX BELOW THE SERVICE HEAD.
- E. 150 DRIP LOOP TO BE LEFT AT THE POLE AND HOUSE CONNECTION.
- F. REFER TO CHART SS-1M FOR RECOMMENDED SIZES OF TRIPLEX CABLE TO BE USED.
- G. ANCHORING AND GUYING TO BE IN ACCORDANCE WITH SECTION 'A'.
- H. 2 1/2" GALVANIZED STEEL MASTS. RIGID ALUMINUM CONDUIT IS NOT ACCEPTABLE.
- I. ITEM No.3 IS NOT REQUIRED WHEN THE MAST IS CONNECTED DIRECTLY TO A 2 1/2" HUB ON THE METER CONNECTION BOX.
- J. AT THE DISCRETION OF FIELD ENGINEERING, OR THEIR REPRESENTATIVE, MINIMUM SERVICE ATTACHMENT HEIGHT MAY BE INCREASED OR DECREASED TO MEET CLEARANCE REQUIREMENTS UNDER MAXIMUM SAG CONDITIONS AS SPECIFIED IN CHART J-1M AND SECTION "V".
- K. REFER TO SWM 4.02 FOR CONNECTOR INSTALLATIONS.
- L. THE MAXIMUM SERVICE MAST HEIGHT IS MEASURED FROM LEVEL GROUND. THIS REQUIREMENT MAY BE WAIVED, WITH THE APPROVAL OF NSPI, IF THE SERVICE IS REACHABLE WITH A BOOM TRUCK FROM THE DRIVEWAY.
- M. GUY OR BRACE WHEN ATTACHMENT POINT EXCEEDS 1100 ABOVE THE ROOFLINE.
- N. ALL DIMENSIONS ARE IN MILLIMETERS UNLESS OTHERWISE SHOWN.

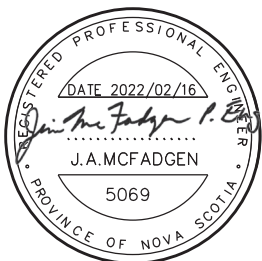

DISTRIBUTION STANDARDS



**TRIPLEX SERVICE CONNECTION
ON SERVICE MAST
120/240V (400A OR LESS)**

DATE:	2008-08-14	REV DATE:	2022-02-16
DRAWN:	M. HALASZ	STD NO:	SS-ED-13M
APPROVED:	J. A. MCFADGEN	SHT NO:	1 OF 1 (R4)

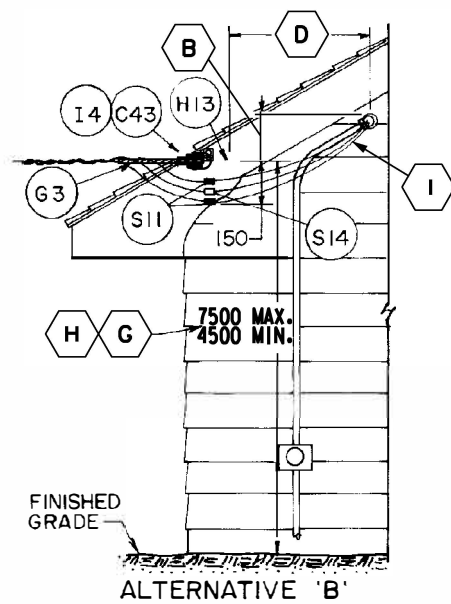
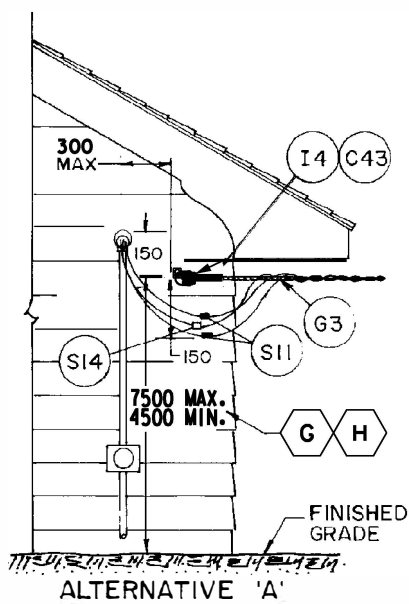
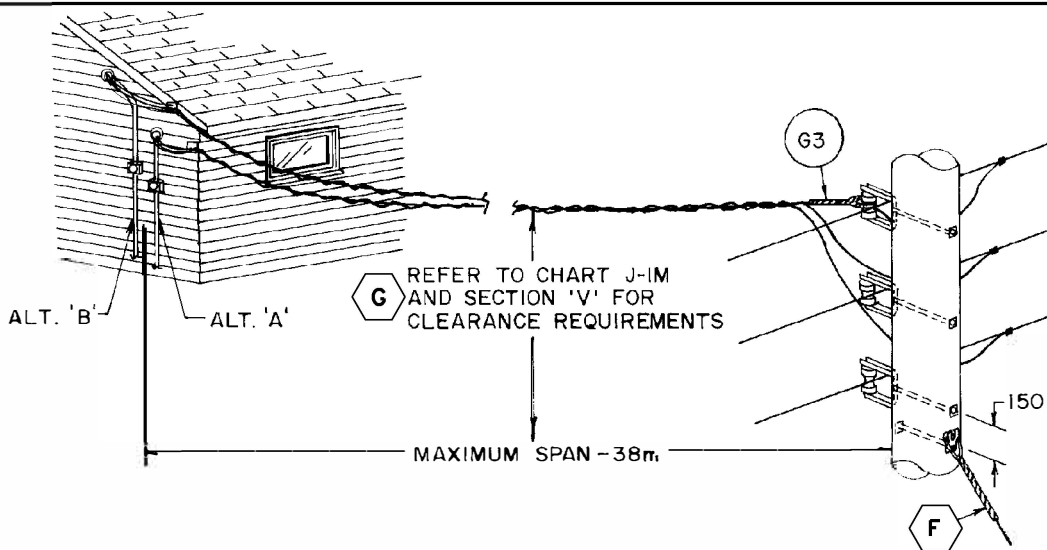

NOTES:

- A. FOR RE-CONNECTION OF AN EXISTING SERVICE NSPI SHALL SUPPLY AND INSTALL THE SERVICE ATTACHMENT DEVICE.
- B. SERVICE ATTACHMENT SHALL BE INSTALLED 150MM MIN AND 300MM MAX BELOW THE SERVICE HEAD.
- C. 150MM DRIP LOOP TO BE LEFT AT THE POLE AND HOUSE CONNECTION.
- D. SERVICE ATTACHMENT SHALL BE INSTALLED 150MM MIN AND 300MM MAX HORIZONTAL DISTANCE FROM THE SERVICE HEAD. THE MAX MAY BE INCREASED TO 500MM FOR UNDER EAVE INSTALLATIONS.
- E. REFER TO CHART SS-1M FOR RECOMMENDED SIZES OF TRIPLEX CABLE TO BE USED.
- F. ANCHORING AND GUYING TO BE IN ACCORDANCE WITH SECTION 'A'.
- G. AT THE DISCRETION OF FIELD ENGINEERING, OR THEIR REPRESENTATIVE, MINIMUM SERVICE ATTACHMENT HEIGHT MAY BE INCREASED OR DECREASED TO MEET CLEARANCE REQUIREMENTS UNDER MAXIMUM SAG CONDITIONS AS SPECIFIED IN CHART J-1M AND SECTION "V".
- H. THE MAXIMUM SERVICE MAST HEIGHT IS MEASURED FROM LEVEL GROUND. THIS REQUIREMENT MAY BE WAIVED, WITH THE APPROVAL OF NSPI, IF THE SERVICE IS REACHABLE WITH A BOOM TRUCK FROM THE DRIVEWAY.
- I. CUSTOMER'S SERVICE ENTRANCE CONDUCTORS SHALL EACH EXTEND NOT LESS THAN 1000MM BEYOND THE SERVICE HEAD TO ALLOW FOR UTILTY CONNECTIONS.
- J. ALL DIMENSIONS ARE IN MILLIMETERS UNLESS OTHERWISE SHOWN.

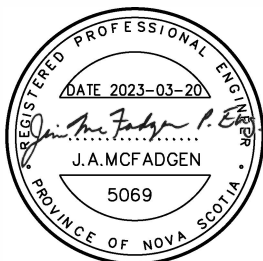

DISTRIBUTION STANDARDS



**TRIPLEX SERVICE CONNECTIONS
FOR EXISTING SINGLE DWELLINGS
120/240V (400A OR LESS)**

DATE:	2008-08-14	REV DATE:	2023-03-20
DRAWN:	M. HALASZ	STD NO:	SS-ED-14M
APPROVED:	J. A. MCFADGEN	SHT NO:	1 OF 1

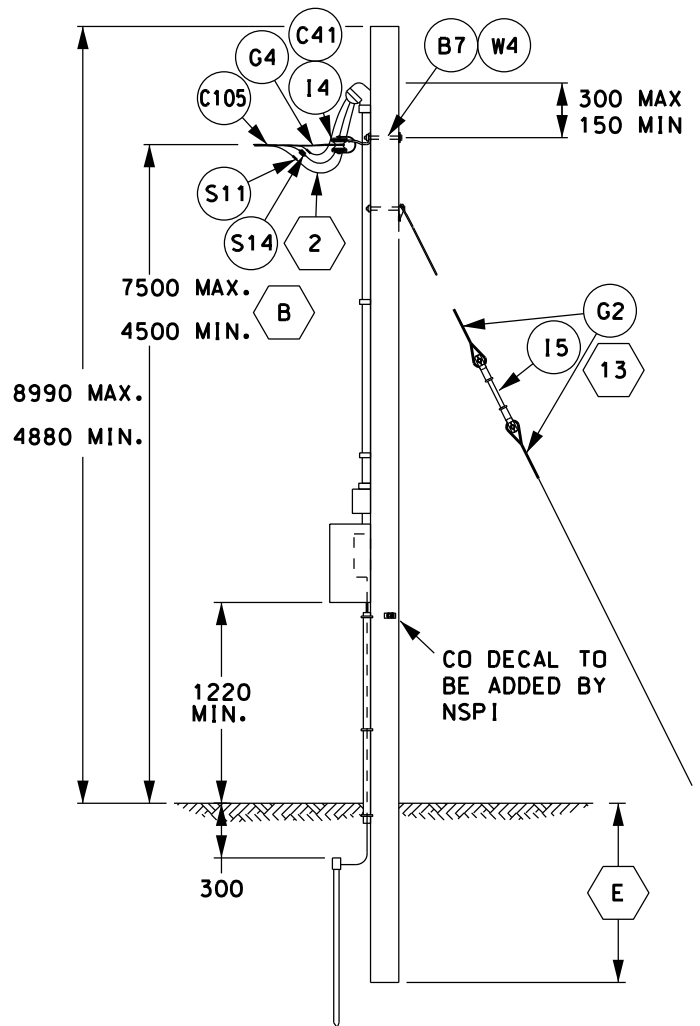
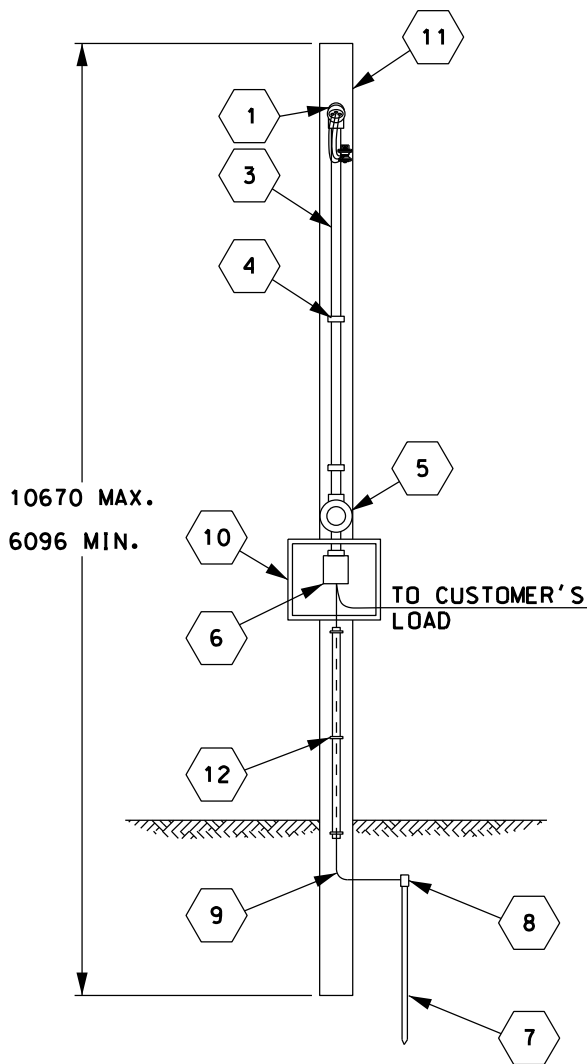

CUSTOMER'S MATERIAL

1. SERVICE HEAD
2. SERVICE ENTRANCE CONDUCTOR, INSULATED
3. CONDUIT
4. SERVICE MAST CLAMPS, GALVANIZED
5. SOCKET METER BASE
6. SERVICE ENTRANCE SWITCH RATED NEMA3
7. GROUND ROD IN ACCORDANCE WITH C.E. CODE PART I

8. GROUND ROD CLAMP
9. GROUND WIRE IN ACCORDANCE WITH C.E. CODE PART I
10. 20mm WOOD MOUNTING BOARD OR WEATHERPROOF BOX
11. SUPPORTING STRUCTURE TO BE SUPPLIED BY CONTRACTOR - WOOD POLE MINIMUM CLASS 7 (25FT AND UNDER) AND CLASS 5 (UP TO 35FT)
12. COVERING, GROUND WIRE MOLDING PER C.E. CODE PART 1.
13. GUYING ASSEMBLY

NOTES:

- A. FASTEN MOUNTING BOARD/BOX SECURELY TO POLE.
- B. SERVICE ATTACHMENT HEIGHT SHALL BE INCREASED, TO A MAXIMUM OF 7.5M, WHERE ADDITIONAL GROUND CLEARANCE IS REQUIRED. FOR TEMPORARY POLES 25FT AND UNDER, A MINIMUM CLASS 7 POLE IS REQUIRED. FOR ALL OTHER POLES UP TO 35FT, POLE SHALL BE MINIMUM CLASS 5. A MANUFACTURERS STAMP IS REQUIRED TO INDICATE POLE CLASS.
- C. CUSTOMER SET POLES TALLER THAN 25FT MUST BE BUCKET TRUCK ACCESSIBLE.
- D. POLES SHALL BE TREATED WOOD, UNLESS OTHERWISE APPROVED BY SUPPLY AUTHORITY. POLES SHALL BE IN GOOD CONDITION, FREE OF CRACKS, CHECKS AND ROT.
- E. SETTING DEPTH IS TO BE 10% OF THE POLE LENGTH PLUS 2 FEET.
- F. ALL DIMENSIONS ARE IN MILLIMETERS UNLESS OTHERWISE SHOWN.

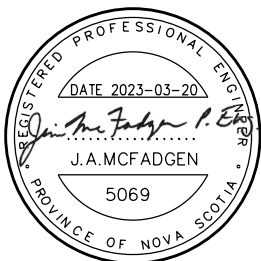

DISTRIBUTION STANDARDS



**TEMPORARY SERVICE STRUCTURE WITH WOOD POLE
120/240 VOLTS (200 AMP OR LESS)**

DATE:	2008-08-14	REV DATE:	2023-03-20
DRAWN:	M. HALASZ	STD NO:	SS-ED-22M
APPROVED:	J. A. MCFADGEN	SHT NO:	1 OF 1 (R2)

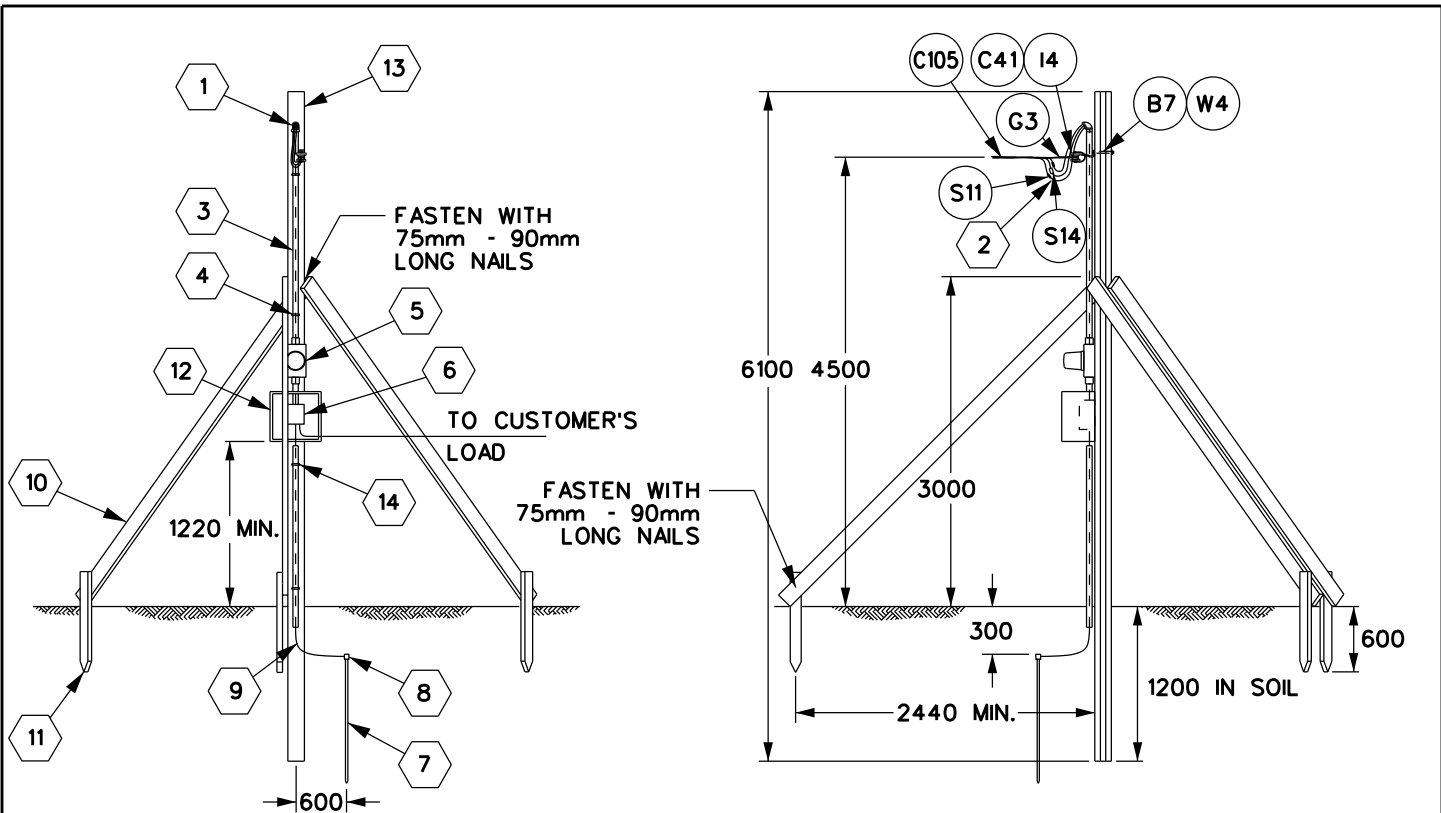

No. CUSTOMER'S MATERIAL

1. SERVICE HEAD
2. SERVICE ENTRANCE CONDUCTOR, INSULATED
3. CONDUIT
4. SERVICE MAST CLAMPS, GALVANIZED
5. SOCKET METER BASE
6. SERVICE ENTRANCE SWITCH RATED NEMA3
7. GROUND ROD IN ACCORDANCE WITH C.E. CODE PART 1
8. GROUND ROD CLAMP
9. GROUND WIRE IN ACCORDANCE WITH C.E. CODE PART 1
10. MINIMUM 50mm X 150mm WOOD PLANKS
11. MINIMUM 50mm X 100mm WOOD STAKES
12. 20mm WOOD MOUNTING BOARD OR WEATHERPROOF BOX
13. SUPPORTING STRUCTURE TO BE SUPPLIED BY CONTRACTOR - THREE 50mm X 150mm SPRUCE PLANKS OR SOLID 150mm X 150mm WOOD TIMBER.
14. COVERING, GROUND WIRE MOLDING PER C.E. CODE PART 1.

NOTES:

- A. FASTEN MOUNTING BOARD/BOX SECURELY TO POLE.
- B. THE ELECTRICAL INSPECTOR OR FIELD ENGINEER, OR THEIR REPRESENTATIVES MUST ENSURE THE TEMPORARY SUPPORT IS SAFE FOR SERVICE ATTACHMENT AND REJECT ALL THOSE CONSIDERED TO BE INADEQUATE.
- C. ALL DIMENSIONS ARE IN MILLIMETERS UNLESS OTHERWISE SHOWN.

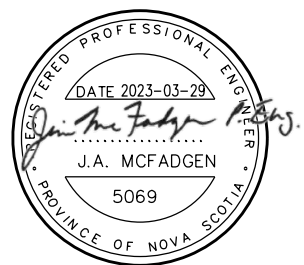

DISTRIBUTION STANDARDS

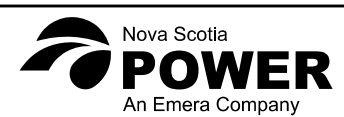

**TEMPORARY SERVICE STRUCTURE WITH PLANKS
120/240 VOLTS (200 AMPS OR LESS)**

DATE:	2008-08-14	REV DATE:	2023-03-29
DRAWN:	M. HALASZ	STD NO:	SS-ED-23M
APPROVED:	J. A. MCFADGEN	SHT NO:	1 OF 1 (R2)

No. CUSTOMER'S MATERIAL

1. SERVICE HEAD.
2. SERVICE ENTRANCE CONDUCTOR, INSULATED.
3. CONDUIT.
4. SERVICE MAST CLAMPS.
5. SOCKET METER BASE.
6. SERVICE ENTRANCE SWITCH RATED NEMA3
7. GROUND ROD IN ACCORDANCE WITH CANADIAN ELECTRICAL CODE, PART 1.
8. GROUND ROD CLAMP.
9. GROUND WIRE AND COVERING, PER C.E. CODE PART 1.
10. MINIMUM 50mm X 150mm X 4880mm WOOD PLANKS.
11. MINIMUM 50mm X 100mm WOOD STAKES.
12. 20mm WOOD MOUNTING BOARD OR WEATHERPROOF BOX. METER TO BE LOCATED OUTSIDE OF BOX.
13. SUPPORTING STRUCTURE TO BE SUPPLIED BY CONTRACTOR THREE 50mm X 150mm SPRUCE PLANKS OR SOLID 150mm X 150mm WOOD PLANK.
14. 16 mm GALVANIZED MACHINE BOLTS THROUGH PLANKS.
15. MINIMUM 50mm X 100mm CROSS BRACES.

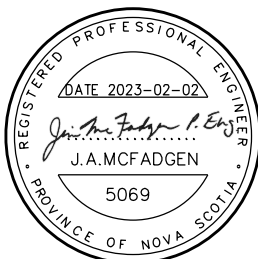
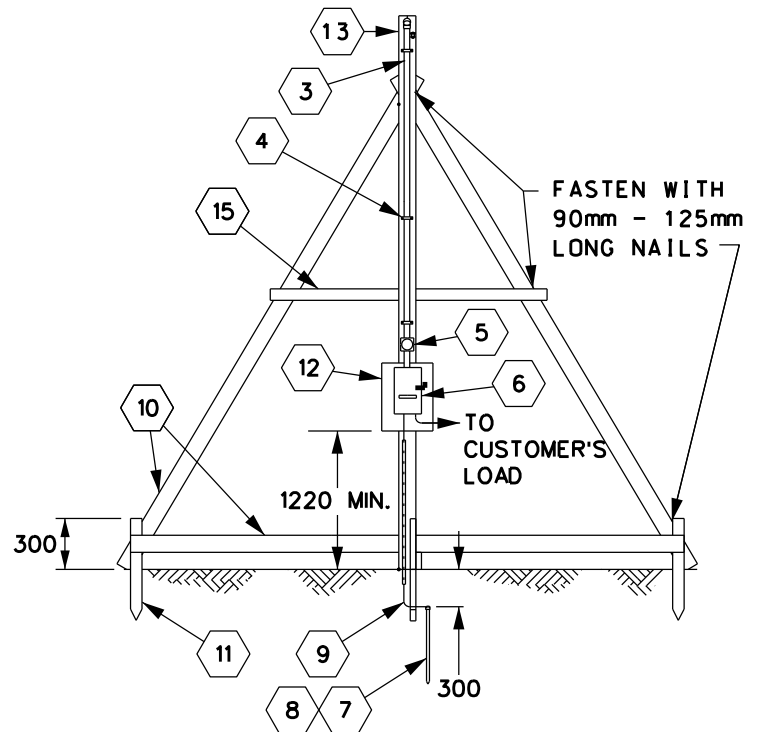
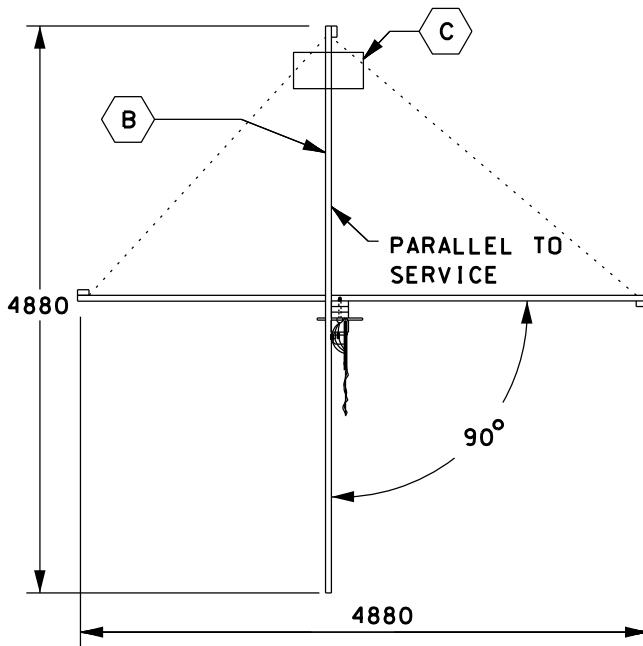
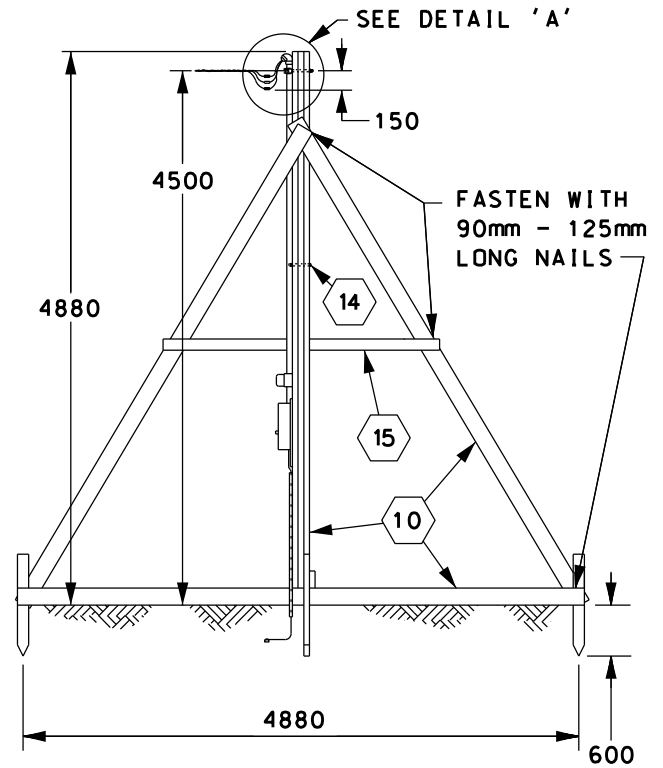

DISTRIBUTION STANDARDS



**TEMPORARY SERVICE STRUCTURE WITH PLANKS SURFACE MOUNT
120/240 VOLTS (200 AMPS OR LESS)
PLAN, ELEVATIONS, MATERIAL LIST**

DATE:	2008-08-14	REV DATE:	2023-02-02
DRAWN:	M. HALASZ	STD NO:	SS-ED-23MA
APPROVED:	J. A. MCFADGEN	SHT NO:	1 OF 2 (R2)

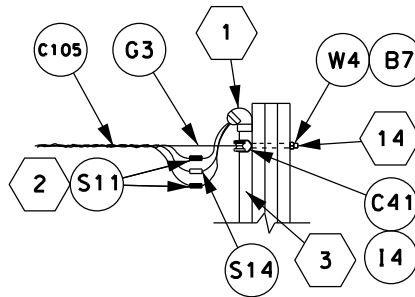

DETAIL 'A'

NOTES:

- A. THE ELECTRICAL INSPECTOR, FIELD ENGINEER OR THEIR REPRESENTATIVE MUST ENSURE THE TEMPORARY SUPPORT IS SAFE FOR SERVICE ATTACHMENT AND REJECT ALL THOSE CONSIDERED TO BE INADEQUATE.
- B. STRUCTURE SHOULD BE INSTALLED ON AS LEVEL GROUND AS POSSIBLE WITH FOUR 50 mm X 150 mm WOOD PLANKS FOR BRACING DOWN TO THE 50 mm X 150 mm CROSS MEMBERS ON THE GROUND.
- C. IF PROPER STAKING CANNOT BE OBTAINED THEN MINIMUM 50 kg WEIGHTS PLACED ON 20 mm PLYWOOD NAILED TO CROSS BRACES SHALL BE USED.
- D. ALL DIMENSIONS ARE IN MILLIMETERS UNLESS OTHERWISE SHOWN.



DISTRIBUTION STANDARDS



**TEMPORARY SERVICE STRUCTURE WITH PLANKS SURFACE MOUNT
120/240 VOLTS (200 AMPS OR LESS)
DETAIL 'A' AND NOTES**

DATE:	2008-08-14	REV DATE:	2023-02-02
DRAWN:	M. HALASZ	STD NO:	SS-ED-23MA
APPROVED:	J. A. MCFADGEN	SHT NO:	2 OF 2 (R1)

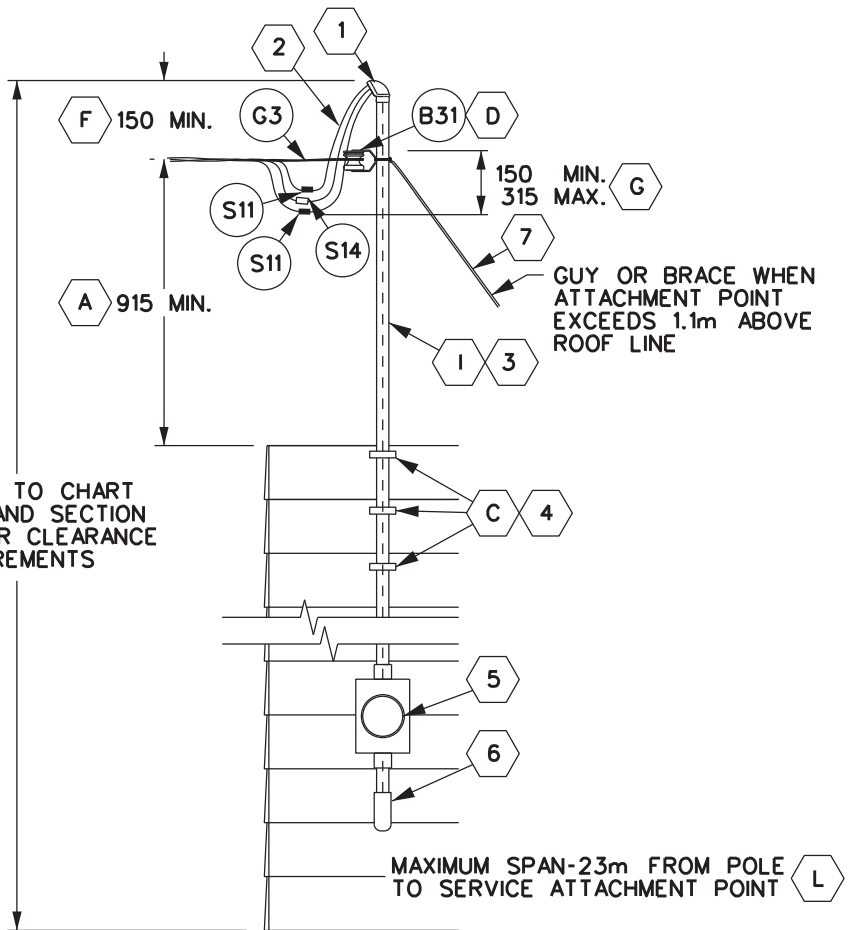

REFER TO CHART J-1M AND SECTION 'V' FOR CLEARANCE REQUIREMENTS

CUSTOMER'S MATERIAL (No.)

- 1. SERVICE HEAD
- 2. SERVICE ENTRANCE CONDUCTORS, INSULATED
- 3. MAST SUPPORT MEMBER
- 4. SERVICE MAST CLAMPS, 2 1/2" GALV., BOLTED TYPE (FOR WALL SUPPORT DETAILS SEE DWG. No. SS-ED-25M)
- 5. METER BASE
- 6. RIGID CONDUIT AND FITTINGS 6mm GALVANIZED STEEL WIRE

NOTES:

- A. WHERE THE SERVICE CROSSES OVER, OR RUNS PARALLEL TO, THE MOBILE HOME ROOF TO ATTACH TO THE SERVICE BRACKET, MINIMUM CLEARANCES TO THE ROOF LINE SHALL BE 1.0m.
- B. THE CUSTOMER SHALL BE RESPONSIBLE FOR INSTALLING THE SERVICE BRACKET AND MAST IN A LOCATION SATISFACTORY TO BOTH THE INSPECTION DEPT. AND THE SUPPLY AUTHORITY AND ENSURING THE ATTACHMENT WILL SUPPORT A HORIZONTAL LOAD OF 3 kN.
- C. THE CUSTOMER SHALL BE RESPONSIBLE FOR PROVIDING WALL SUPPORT FOR THE MAST IN ACCORDANCE WITH DISTRIBUTION STANDARD DWG. No. SS-ED-25.
- D. MATERIAL REQUIRED FOR SERVICE ATTACHMENT SHALL BE SUPPLIED BY NSP.
- E. CUSTOMER'S SERVICE ENTRANCE CONDUCTORS SHALL EACH EXTEND NOT LESS THAN 1000mm BEYOND THE SERVICE HEAD TO ALLOW FOR UTILITY CONNECTIONS.
- F. SERVICE ATTACHMENT SHALL BE INSTALLED A MINIMUM OF 150mm AND MAXIMUM OF 300mm BELOW THE SERVICE HEAD.
- G. DRIP LOOP TO BE LEFT AT POLE AND HOUSE CONNECTION.
- H. REFER TO CHART SS-1M FOR RECOMMENDED SIZES OF TRIPLEX CABLE TO BE USED.
- I. 2 1/2" GALVANIZED STEEL MAST TUBING OR 2 1/2" MINIMUM RIGID STEEL CONDUIT ARE ACCEPTABLE AS SERVICE MASTS. RIGID ALUMINUM CONDUIT IS NOT ACCEPTABLE.
- J. AT THE DISCRETION OF THE FIELD ENGINEER OR THEIR REPRESENTATIVE, MINIMUM SERVICE ATTACHMENT HEIGHT MAY BE INCREASED OR DECREASED TO MEET CLEARANCE REQUIREMENTS UNDER MAXIMUM SAG CONDITIONS AS SPECIFIED IN CHART J-1M AND SECTION 'V'
- K. REFER TO SWM 4.02 FOR CONNECTOR INSTALLATIONS.
- L. REFER TO ELECTRICAL INSPECTION BULLETIN B-06-112 FOR MAX. SPAN MAY BE INCREASED TO 38m PROVIDED AN APPROVED MAST SUPPORT SYSTEM IS USED.
- M. THE MAXIMUM SERVICE MAST HEIGHT IS MEASURED FROM LEVEL GROUND. THIS REQUIREMENT MAY BE WAIVED, WITH THE APPROVAL OF NSPI IF THE SERVICE IS REACHABLE WITH A BOOM TRUCK FROM THE DRIVEWAY.
- N. ALL DIMENSIONS ARE IN MILLIMETERS UNLESS OTHERWISE SHOWN.

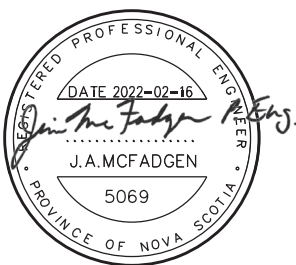

DISTRIBUTION STANDARDS



**TRIPLEX SERVICE CONNECTION FOR MOBILE HOME
120/240V (200A OR LESS)
EXTERIOR DETAILS OF CUSOMER'S SERVICE
MAST INSTALLATION**

DATE:	2008-08-14	REV DATE:	2022-02-16
DRAWN:	M. HALASZ	STD NO:	SS-ED-24M
APPROVED:	J. A. MCFADGEN	SHT NO:	1 OF 1 (R2)

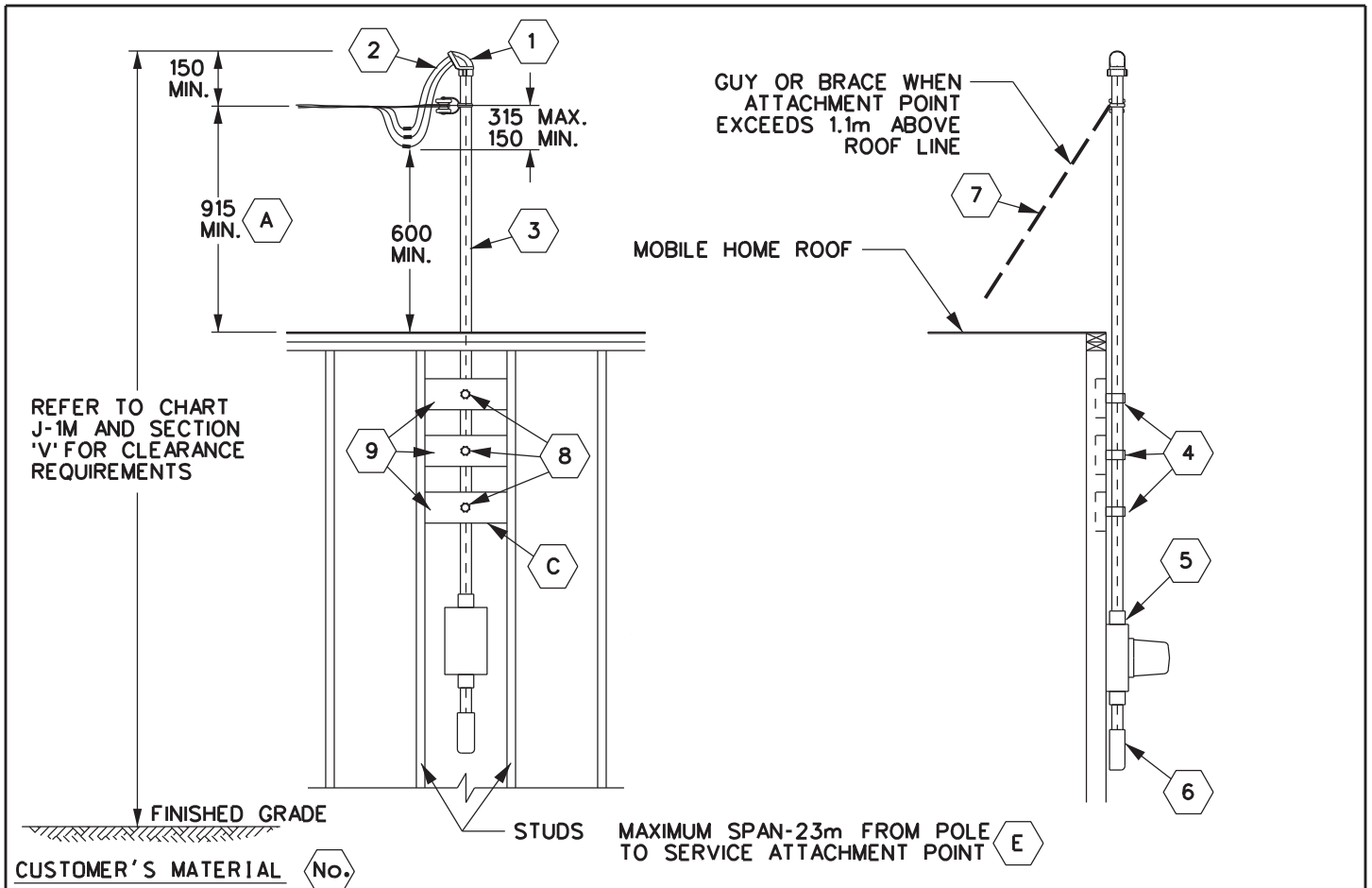

1. SERVICE HEAD
2. SERVICE CONDUCTORS, INSULATED.
3. MAST SUPPORT MEMBER
4. SERVICE MAST CLAMP, 2 1/2" GALV., BOLTED-TYPE
5. METER BASE
6. RIGID CONDUIT AND FITTINGS
7. 6mm GALVANIZED STEEL WIRE
8. 1/2" GALVANIZED BOLT AND SQUARE WASHER
9. 50mm X 150mm WOODEN MEMBERS SECURED BETWEEN STUDS OR ON INTERIOR WALL SURFACE.

NOTES:

- A. WHERE THE SERVICE CROSSES OVER, OR RUNS PARALLEL TO, THE MOBILE HOME ROOF TO ATTACH TO THE SERVICE BRACKET, THE MINIMUM CLEARANCE TO THE ROOF LINE SHALL BE 1.0m.
- B. THE CUSTOMER SHALL BE RESPONSIBLE FOR INSTALLING THE SERVICE BRACKET AND MAST IN A LOCATION SATISFACTORY TO BOTH THE INSPECTION DEPARTMENT AND THE SUPPLY AUTHORITY, AND ENSURING THE ATTACHMENT WILL SUPPORT A HORIZONTAL LOAD OF 3 kN.
- C. THE CUSTOMER SHALL BE RESPONSIBLE FOR PROVIDING WALL SUPPORT FOR THE SERVICE MAST BY MEANS OF CLAMPS BOLTED THROUGH THE EXTERIOR WALL AND 50mm X 150mm WOODEN MEMBERS SECURED BETWEEN STUDS OR ON AN INTERIOR WALL SURFACE.
- D. REFER TO SWM 4.02 FOR CONNECTOR INSTALLATIONS.
- E. REFER TO ELECTRICAL INSPECTION BULLETIN B-06-112 FOR MAX. SPAN MAY BE INCREASED TO 38m PROVIDED AN APPROVED MAST SUPPORT SYSTEM IS USED.
- F. THE MAXIMUM SERVICE MAST HEIGHT IS MEASURED FROM LEVEL GROUND. THIS REQUIREMENT MAY BE WAIVED, WITH THE APPROVAL OF NSPI, IF THE SERVICE IS REACHABLE WITH A BOOM TRUCK FROM DRIVEWAY.
- G. ALL DIMENSIONS ARE IN MILLIMETERS UNLESS OTHERWISE SHOWN.

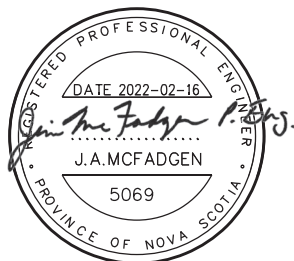

DISTRIBUTION STANDARDS



**TRIPLEX SERVICE CONNECTION FOR MOBILE HOME
120/240V (200A OR LESS)
CUSTOMER'S INSTALLATION AND
WALL SUPPORT OF SERVICE MAST**

DATE:	2008-08-14	REV DATE:	2022-02-16
DRAWN:	M. HALASZ	STD NO:	SS-ED-25M
APPROVED:	J. A. MCFADGEN	SHT NO:	1 OF 1 (R2)

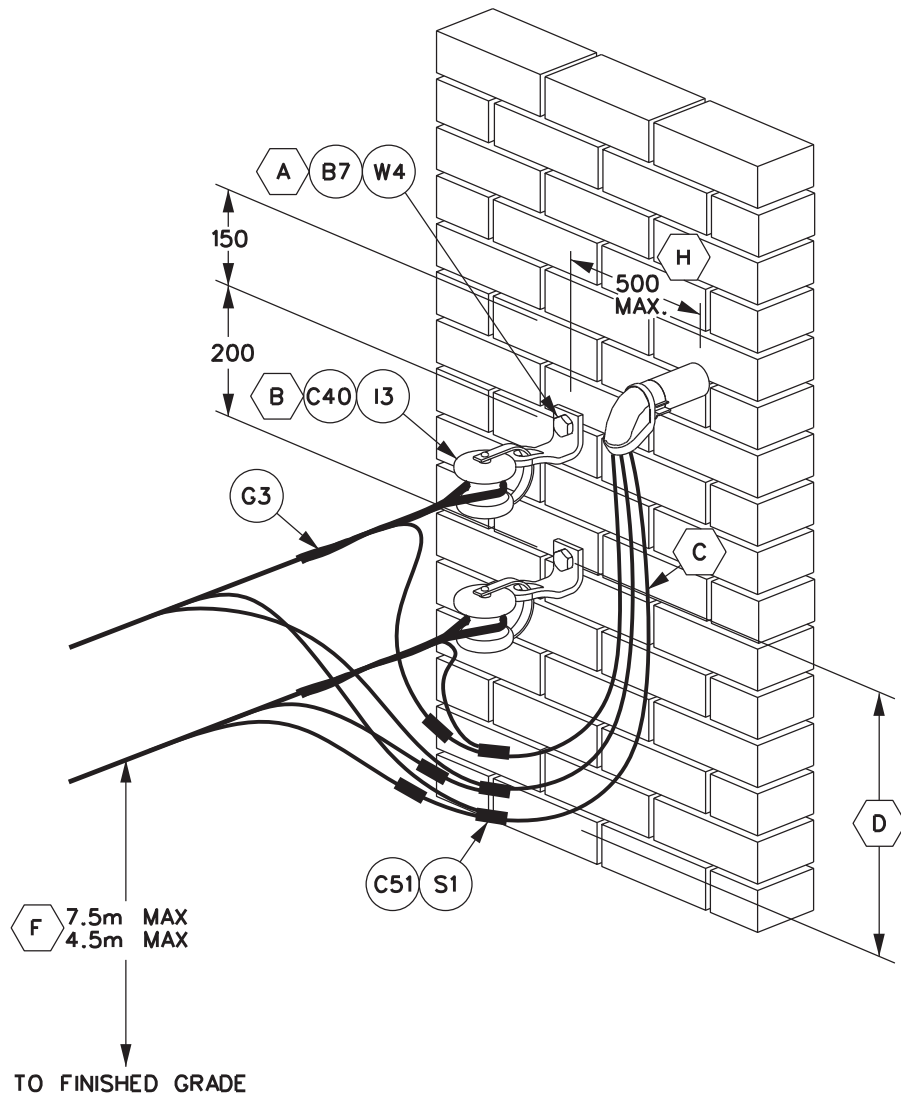

NOTES:

- A. THE CUSTOMER SHALL BE RESPONSIBLE FOR INSTALLING THE SERVICE ATTACHEMENT DEVICE IN A LOCATION SATISFACTORY TO BOTH THE INSEPCION DEPT. AND THE SUPPLY AUTHORITY, AND ENSURING THE ATTACHMENT WILL SUPPORT A HORIZONTAL LOAD OF 3KN.
- B. MATERIAL REQUIRED FOR SERVICE ATTACHEMENT TO THE BUILDING SHALL BE SUPPLIED BY NSPI.
- C. CUSTOMER'S SERVICE ENTRANCE CONDUCTORS SHALL EXTEND NOT LESS THAN 1000mm BEYOND THE SERVICE HEAD TO ALLOW FOR UTILITY CONNECTIONS.
- D. 150mm DRIP LOOP TO BE LEFT AT POLE AND HOUSE CONNECTION.
- E. REFER TO CHARTS SS-1M - SS-4M FOR RECOMMENDED SERVICE CONDUCTOR SIZES TO BE USED. FOR SINGLE CABLE INSTALLATION OMIT THE BOTTOM CIRCUIT.
- F. AT THE DISCRETION OF THE FIELD ENGINEER OR THEIR REPRESENTATIVE. MINIMUM SERVICE ATTACHEMENT HEIGHT MAY BE INCREASED OR DECREASED TO MEET CLEARANCE REQUIREMENTS UNDER MAXIMUM SAG CONDITIONS AS SPECIFIED IN CHART J-1, AND SECTION 'V'.
- G. THE MAXIMUM SERVICE MAST HEIGHT IS MEASURED FROM LEVEL GROUND. THIS REQUIREMENT MAY BE WAIVED, WITH THE APPROVAL OF NSPI, IF THE SERVICE IS REACHABLE WITH A BOOM TRUCK FROM THE DRIVEWAY.
- H. FOR NEW CONSTRUCTION MAXIMUM OF 300mm FOR EXISTING CONSTRUCTION THIS MAY BE UP TO 500mm.
- I. ALL DIMENSIONS IN MILLIMETERS UNLESS OTHERWISE SHOWN.

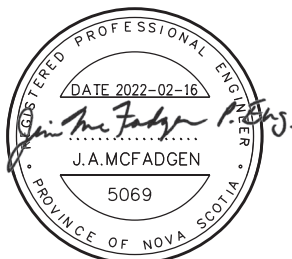

DISTRIBUTION STANDARDS



**PARALLEL SERVICE CONNECTION
AT THE SERVICE ENTRANCE
TRIPLEX OR QUADRUPLIX**

DATE:	2008-08-14	REV DATE:	2022-02-16
DRAWN:	M. HALASZ	STD NO:	SS-ED-26M
APPROVED:	J. A. MCFADGEN	SHT NO:	1 OF 1 (R2)

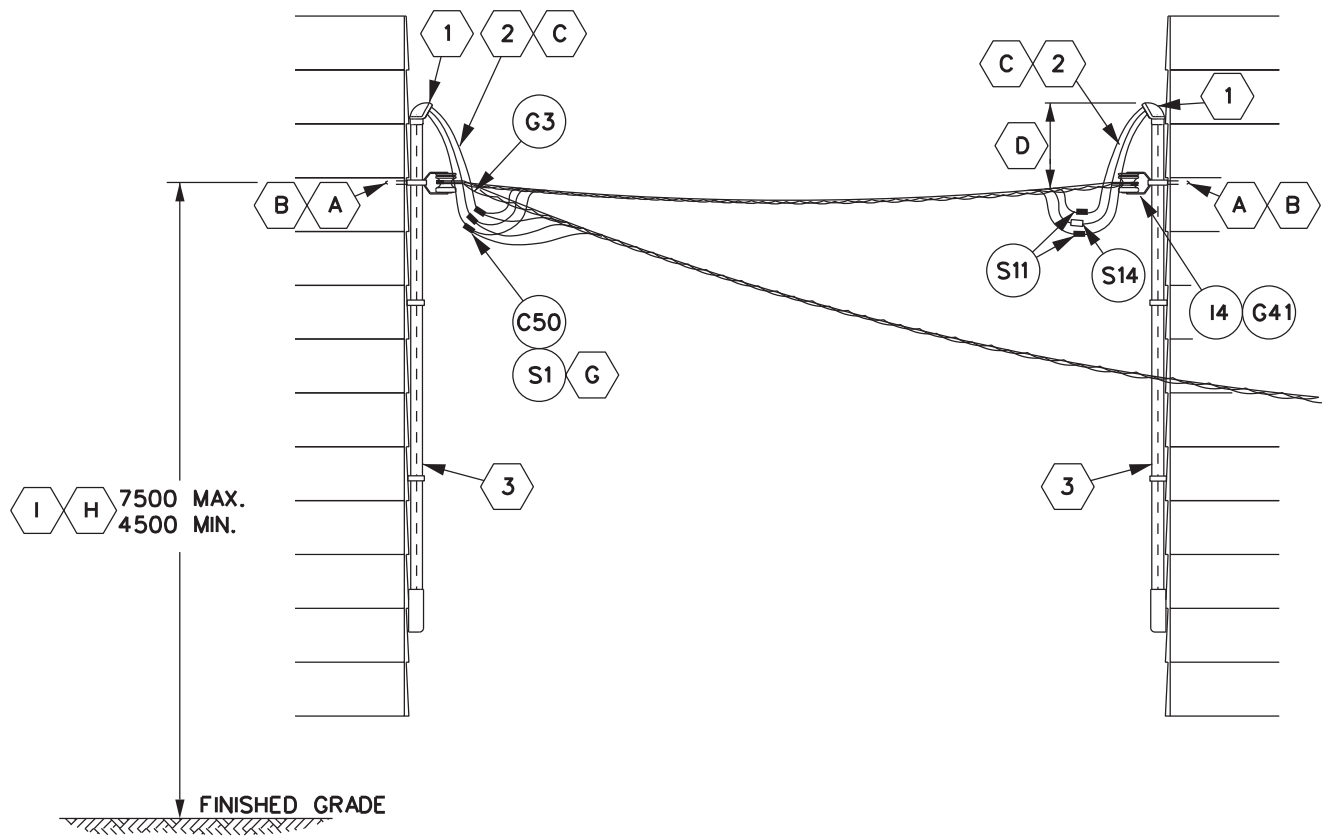

CUSTOMER'S MATERIAL (No.)

1. SERVICE HEAD
2. SERVICE ENTRANCE CONDUCTOR, INSULATED
3. RIGID CONDUIT

NOTES:

- A. THE CUSTOMER SHALL BE RESPONSIBLE FOR INSTALLING THE SERVICE ATTACHMENT DEVICE TO THE BUILDING AT THE TIME OF CONSTRUCTION AND ENSURING THE ATTACHMENT WILL SUPPORT A HORIZONTAL LOAD OF 3kN.
- B. MATERIAL REQUIRED FOR SERVICE ATTACHMENT SHALL BE SUPPLIED BY NSPI.
- C. CUSTOMER'S SERVICE ENTRANCE CONDUCTORS SHALL EACH EXTEND NOT LESS THAN 1000mm BEYOND THE SERVICE HEAD TO ALLOW FOR UTILITY CONNECTIONS.
- D. SERVICE ATTACHMENT SHALL BE INSTALLED A MINIMUM OF 150mm AND MAXIMUM OF 300mm BELOW THE SERVICE HEAD.
- E. 150mm DRIP LOOP TO BE LEFT AT THE POLE AND HOUSE CONNECTION.
- F. REFER TO CHART SS-1M FOR RECOMMENDED SIZES OF TRIPLEX CABLE TO BE USED.
- G. PHASE COMPRESSION CONNECTIONS SHALL HAVE SEALING PAD COVERS OR EQUIVALENT AND ALL NEUTRAL CONNECTIONS SHALL BE BARE.
- H. AT THE DISCRETION OF FIELD ENGINEERING, OR THEIR REPRESENTATIVE, MINIMUM SERVICE ATTACHMENT HEIGHT MAY BE INCREASED OR DECREASED TO MEET CLEARANCE REQUIREMENTS UNDER MAXIMUM SAG CONDITIONS AS SPECIFIED IN CHART J-1M AND SECTION 'V'.
- I. THE MAXIMUM SERVICE MAST HEIGHT IS MEASURED FROM LEVEL GROUND. THIS REQUIREMENT MAY BE WAIVED, WITH THE APPROVAL OF NSPI, IF THE SERVICE IS REACHABLE WITH A BOOM TRUCK FROM THE DRIVEWAY.
- J. ALL DIMENSIONS ARE IN MILLIMETERS UNLESS OTHERWISE SHOWN.

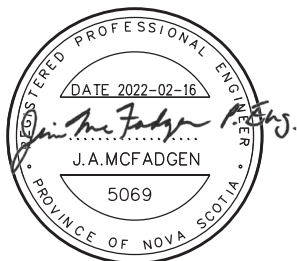

DISTRIBUTION STANDARDS



TRIPLEX SERVICE CONNECTION DETAILS FOR LINKED HOMES

DATE:	1997-11-01	REV DATE:	2022-02-16
DRAWN:	M. HALASZ	STD NO:	SS-ED-30M
APPROVED:	J. A. MCFADGEN	SHT NO:	1 OF 1 (R2)

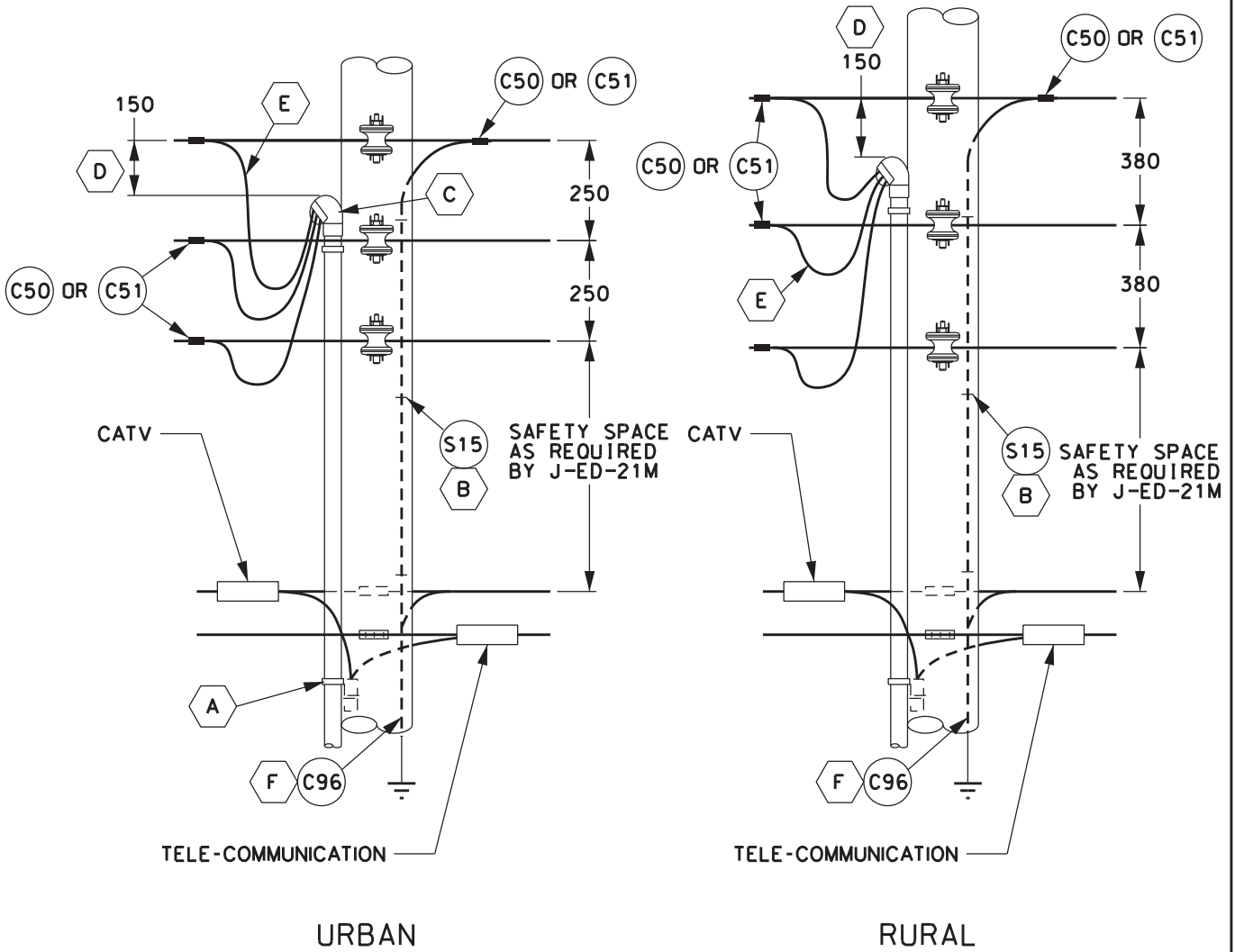

NOTES:

- A. PVC CONDUIT TO BE STRAPPED TO POLE EVERY 1200mm.
- B. GROUND WIRE TO BE STAPLED TO POLE EVERY 600mm.
- C. THE CUSTOMER IS RESPONSIBLE FOR SUPPLYING AND INSTALLED THE SERVICE HEAD, CABLE AND RIGID PVC CONDUIT.
- D. TOP OF THE SERVICE HEAD TO BE LOCATED BETWEEN THE SYSTEM NEUTRAL AND HOTLEG.
- E. MINIMUM LENGTH OF SECONDARY CABLE FROM WEATHERHEAD SHALL BE 1000mm FOR MAKING CONNECTIONS AND DRIP LOOP.
- F. GROUNDING TO BE IN ACCORDANCE WITH G-ED-10M.
- G. ALL DIMENSIONS ARE IN MILLIMETERS UNLESS OTHERWISE SHOWN.

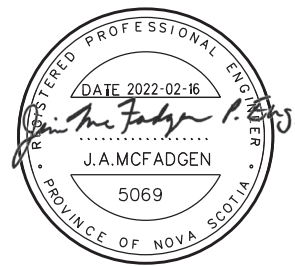

DISTRIBUTION STANDARDS



UNDERGROUND SERVICE FROM SECONDARY DIRECTLY TO A CUSTOMER

DATE:	2022-02-16	REV DATE:	
DRAWN:	M. HALASZ	STD NO:	SS-ED-31M
APPROVED:	J. A. MCFADGEN	SHT NO:	1 OF 1

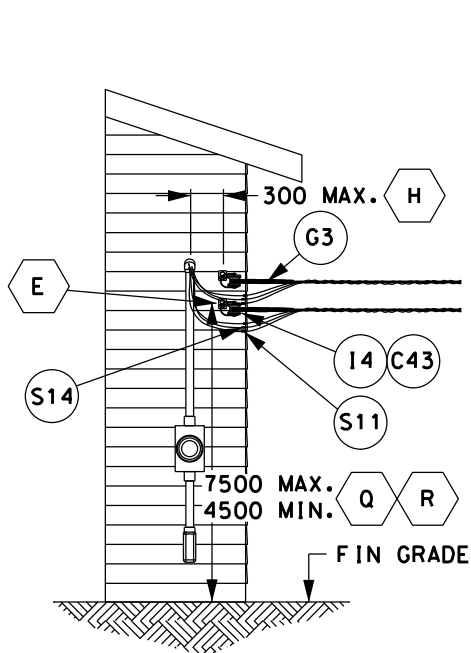
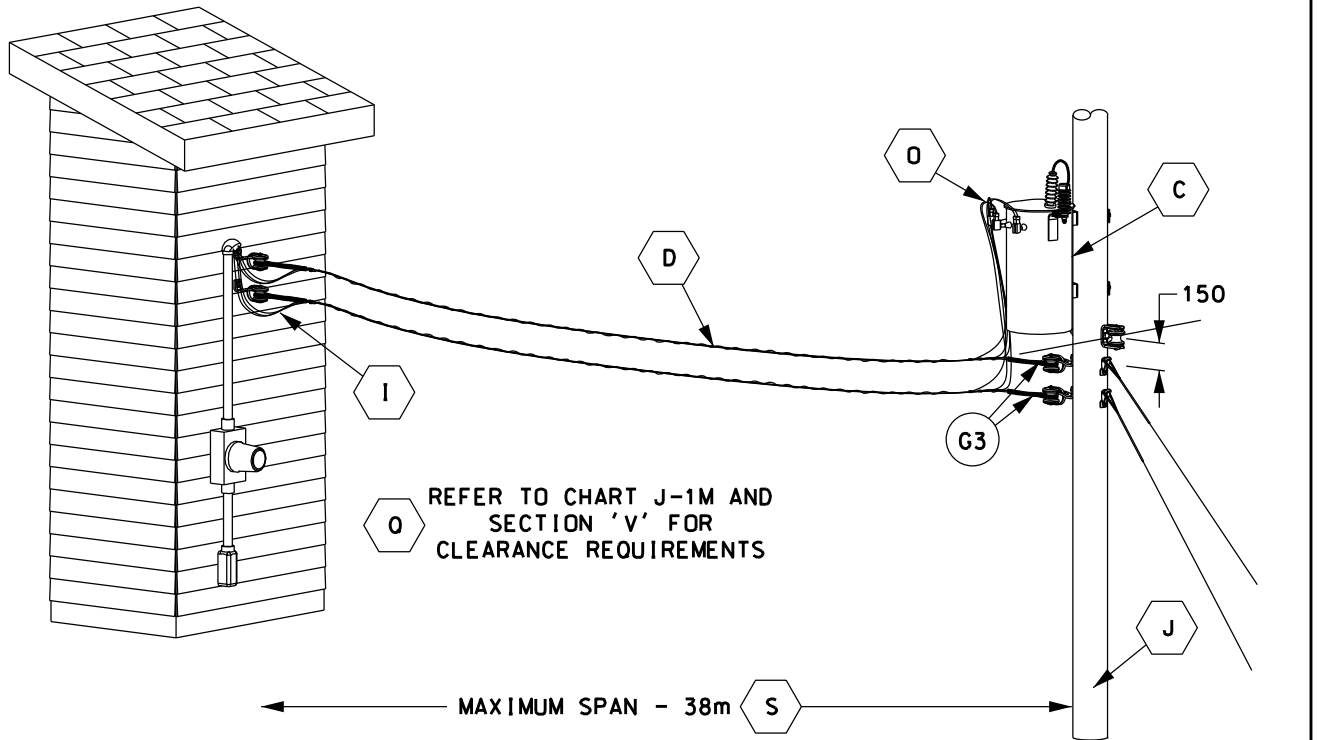

ALTERNATIVE A

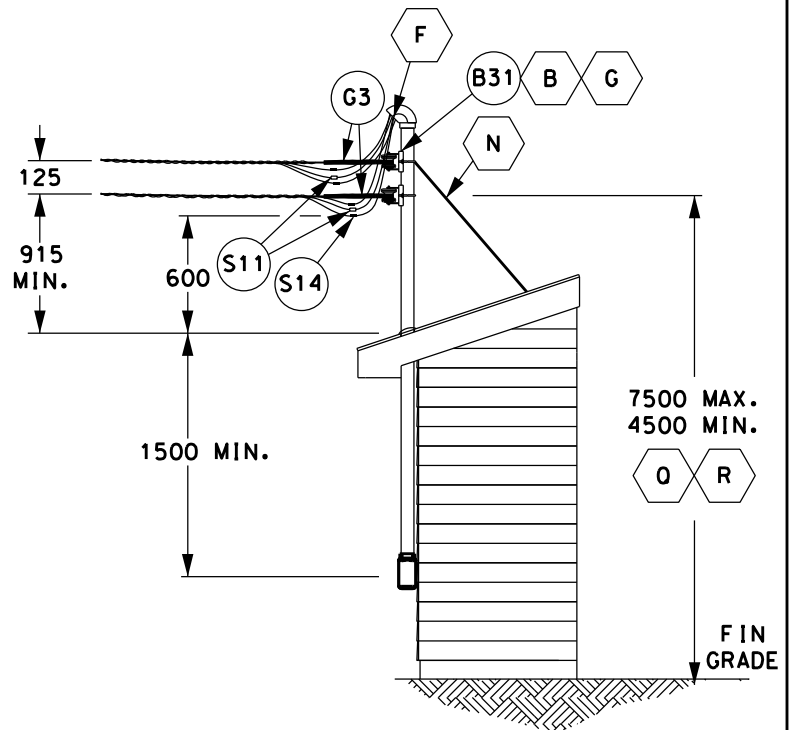

ALTERNATIVE B



DISTRIBUTION STANDARDS



**TRIPLEX SERVICE CONNECTIONS
FOR SINGLE DWELLINGS
600A**

DATE:	2023-04-17	REV DATE:	
DRAWN:	M. HALASZ	STD NO:	SS-ED-32M
APPROVED:		SHT NO:	1 OF 2

NOTES:

- A. THE CUSTOMER SHALL BE RESPONSIBLE FOR INSTALLING THE SERVICE BRACKETS AND MAST IN A LOCATION SATISFACTORY TO BOTH THE INSPECTION DEPT. AND THE SUPPLY AUTHORITY.
- B. MATERIAL REQUIRED FOR SERVICE ATTACHMENT SHALL BE SUPPLIED BY NSPI.
- C. 600A SERVICES ARE NOT PERMITTED TO BE SUPPLIED FROM A SECONDARY BUS.
- D. DUAL RUNS OF TRIPLEX SHALL BE USED UNLESS OTHERWISE PERMITTED IN ACCORDANCE WITH CHART SS-1M.
- E. REFER TO SS-ED-26M FOR PARALLEL SERVICE CONNECTIONS.
- F. CUSTOMER'S SERVICE ENTRANCE CONDUCTORS SHALL EACH EXTEND NOT LESS THAN 1000MM BEYOND THE SERVICE HEAD TO ALLOW FOR UTILITY CONNECTIONS.
- G. SERVICE ATTACHMENT SHALL BE INSTALLED 150MM MIN AND 315MM MAX BELOW THE SERVICE HEAD.
- H. SERVICE ATTACHMENT SHALL BE INSTALLED 150MM AND 300MM MAX HORIZONTAL DISTANCE FROM THE SERVICE HEAD.
- I. 150MM DRIP LOOP TO BE LEFT AT HOUSE CONNECTION.
- J. ANCHORING AND GUYING TO BE IN ACCORDANCE WITH SECTION A.
- K. 2 1/2" GALVANIZED STEEL MASTS. RIGID ALUMINUM CONDUIT IS NOT ACCEPTABLE.
- L. REFER TO SS-ED-13M FOR ADDITIONAL DETAILS ON CUSTOMER MATERIALS (ALTERNATIVE B).
- M. REFER TO SWM 4.02 FOR CONNECTOR INSTALLATIONS.
- N. GUY OR BRACE REQUIRED FOR ALL DUAL RUN SERVICES.
- O. REFER TO SS-ED-21M FOR TRANSFORMER CONNECTION.
- P. UNDER EAVE INSTALLATIONS ARE NOT PERMITTED FOR 600A SERVICES.
- Q. AT THE DISCRETION OF FIELD ENGINEERING, OR THEIR REPRESENTATIVE, MINIMUM SERVICE ATTACHMENT HEIGHT MAY BE INCREASED OR DECREASED TO MEET CLEARANCE.
- R. THE MAXIMUM SERVICE MAST HEIGHT IS MEASURED FROM LEVEL GROUND. THIS REQUIREMENT MAY BE WAIVED, WITH THE APPROVAL OF NSPI. IF THE SERVICE IS REACHABLE WITH A BOOM TRUCK FROM THE DRIVEWAY.
- S. REFER TO V-ED-15M FOR INSTRUCTION ON DETERMINING SERVICE SPAN LENGTH.
- T. ALL DIMENSIONS ARE IN MILLIMETERS UNLESS OTHERWISE SHOWN.



DISTRIBUTION STANDARDS



**TRIPLEX SERVICE CONNECTIONS
FOR SINGLE DWELLINGS
600A - NOTES**

DATE:	2023-04-17	REV DATE:	
DRAWN:	M. HALASZ	STD NO:	SS-ED-32M
APPROVED:		SHT NO:	2 OF 2

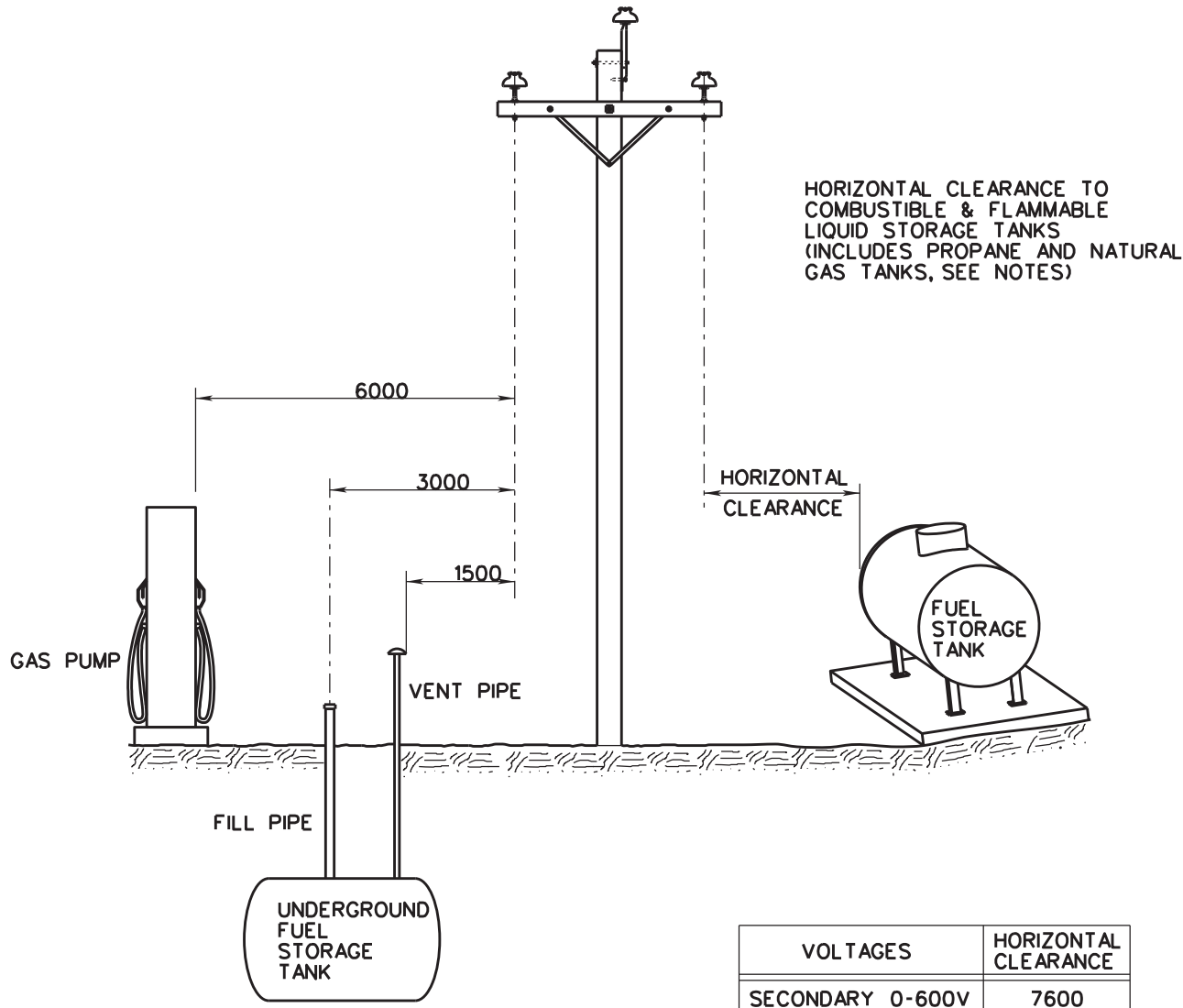

NOTES:

- A. HORIZONTAL CLEARANCES APPLY TO ALL GAS TANKS OF AGGREGATE CAPACITY \geq 7600 LITRES
- B. OVERHEAD LINES, REGARDLESS OF VOLTAGE OR CONSTRUCTION TYPE, MAY NOT PASS OVER ANY FUEL INSTALLATION AS SHOWN.

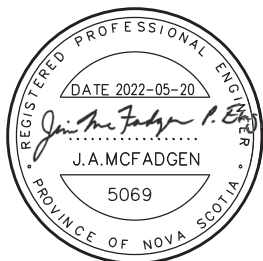

DISTRIBUTION STANDARDS



MINIMUM CLEARANCES FROM CONDUCTOR TO ABOVE GROUND & UNDERGROUND FUEL STORAGE TANKS

DATE:	2008-09-15	REV DATE:	2022-05-20
DRAWN:	M. HALASZ	STD NO:	V-ED-12M
APPROVED:		SHT NO:	1 OF 1

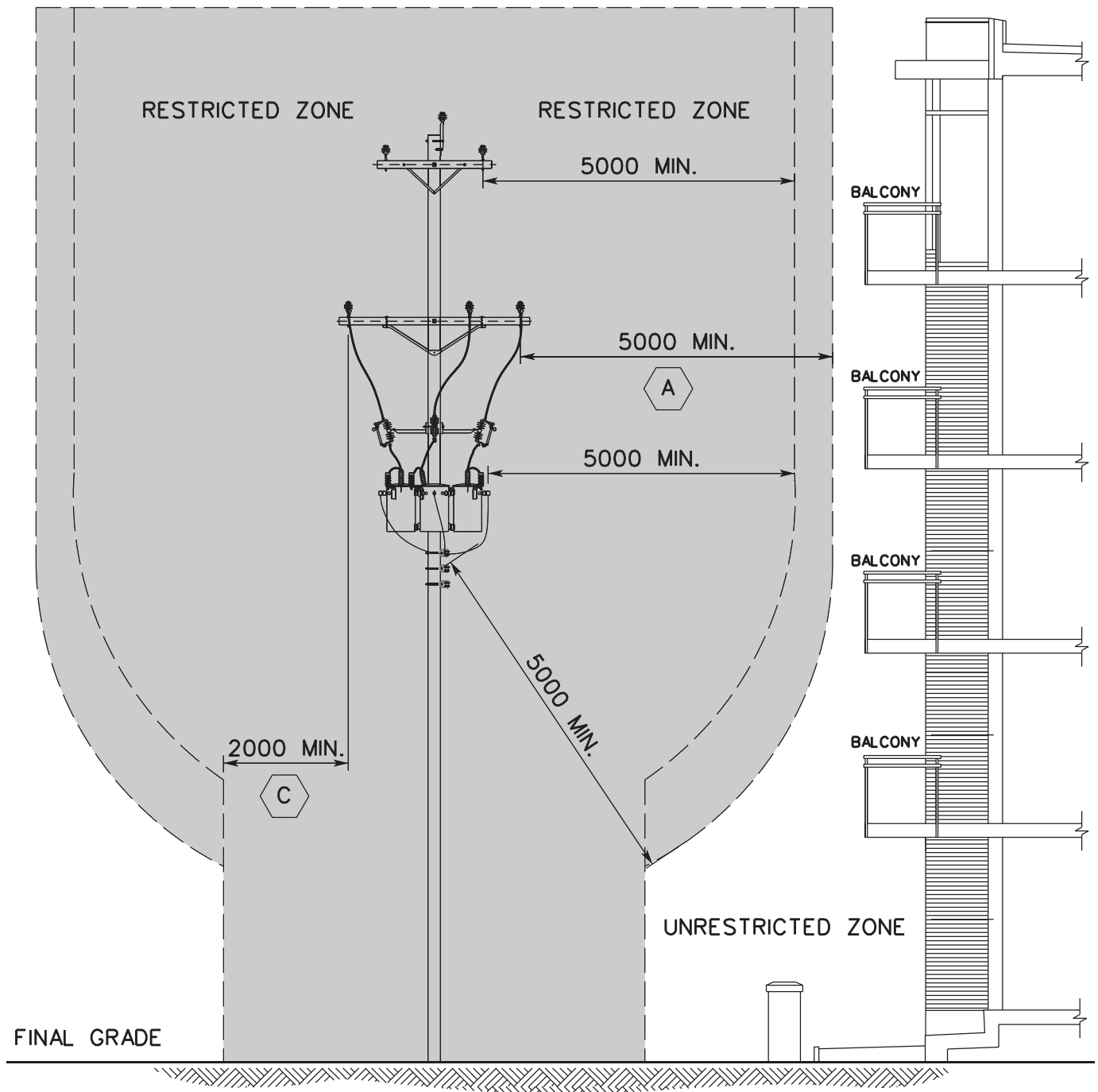

NOTES:

1. SEE SHT. 2 OF 2 FOR GENERAL NOTES.

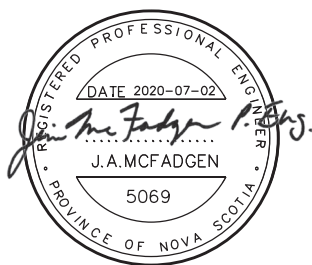

DISTRIBUTION STANDARDS



RECOMMENDED CLEARANCES TO ADJACENT STRUCTURES

DATE:	2020-07-02	REV DATE:	
DRAWN:	M. HALASZ	STD NO:	V-ED-13M
APPROVED:	<i>J.A. MCFADGEN P. Eng.</i>	SHT NO:	1 OF 2

NOTES:

- A. NO PERMANENT BUILDING OR STRUCTURE SHALL BE PLACED WITHIN 5000mm MEASURED RADIALLY FROM ANY PRIMARY VOLTAGE CONDUCTOR OR EQUIPMENT. MEASURED FROM THE CLOSEST PRIMARY CONDUCTOR (AT REST) TO THE CLOSEST POINT OF THE BUILDING OR STRUCTURE.
- B. A MINIMUM HORIZONTAL SEPARATION OF 1500mm FROM THE BUILDING OR STRUCTURE TO SECONDARY CONDUCTOR (<750V) SHALL BE MAINTAINED, UNLESS SECONDARY CONDUCTORS CONNECT SUPPLY TO THE BUILDING'S ELECTRICAL SYSTEM.
- C. NO PERMANENT BUILDING OR STRUCTURE SHALL BE PLACED UNDER A POWER LINE. THE AREA WITHIN 2000mm HORIZONTALLY FROM THE OUTERMOST CONDUCTORS (IN A RESTING POSITION) ON ANY LINE IS CONSIDERED TO BE 'UNDER THE LINE'.
- D. ZERO VOLTAGE SUPPORT WIRES (IE. SPAN GUYS) MAY CROSS OVER THE CUSTOMER'S STRUCTURE AND SHALL MAINTAIN AT LEAST 200mm VERTICAL CLEARANCE TO THE CLOSEST PART OVER THE BUILDING OR STRUCTURE.
- E. CONTACT NSPIDISTRIBUTION STANDARDS ENGINEER TO DETERMINE SPECIFIC CLEARANCES APPLICABLE TO YOUR PROJECT.
- F. SCALE: 1/8" = 1'-0"
- G. ALL DIMENSIONS ARE IN MILLIMETERS UNLESS OTHERWISE SHOWN.

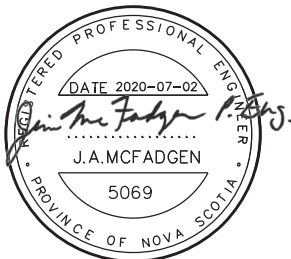

DISTRIBUTION STANDARDS



RECOMMENDED CLEARANCES TO ADJACENT STRUCTURES

DATE:	2020-07-02	REV DATE:	
DRAWN:	M. HALASZ	STD NO:	V-ED-13M
APPROVED:	<i>J. McFadgen P. Eng.</i>	SHT NO:	2 OF 2

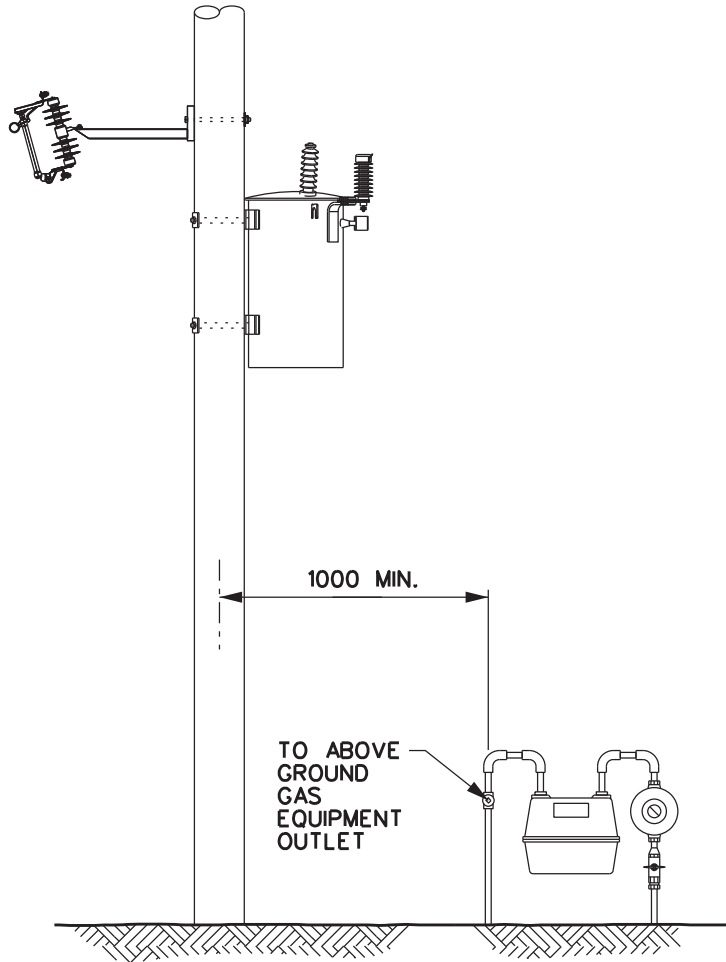

NOTES:

A. THESE CLEARANCES APPLY FROM ANY ELECTRICAL METERING EQUIPMENT, TRANSFORMERS (POLE TOP OR PADMOUNT), OR OVERHEAD SWITCHING EQUIPMENT TO ANY ABOVE GROUND NATURAL GAS EQUIPMENT.

B. ALL DIMENSIONS ARE IN MILLIMETERS UNLESS OTHERWISE SHOWN.

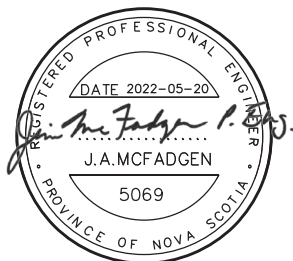

DISTRIBUTION STANDARDS



CLEARANCES TO ABOVE GROUND PROPANE AND NATURAL GAS EQUIPMENT

DATE:	2022-05-20	REV DATE:	
DRAWN:	M. HALASZ	STD NO:	V-ED-14M
APPROVED:		SHT NO:	1 OF 2

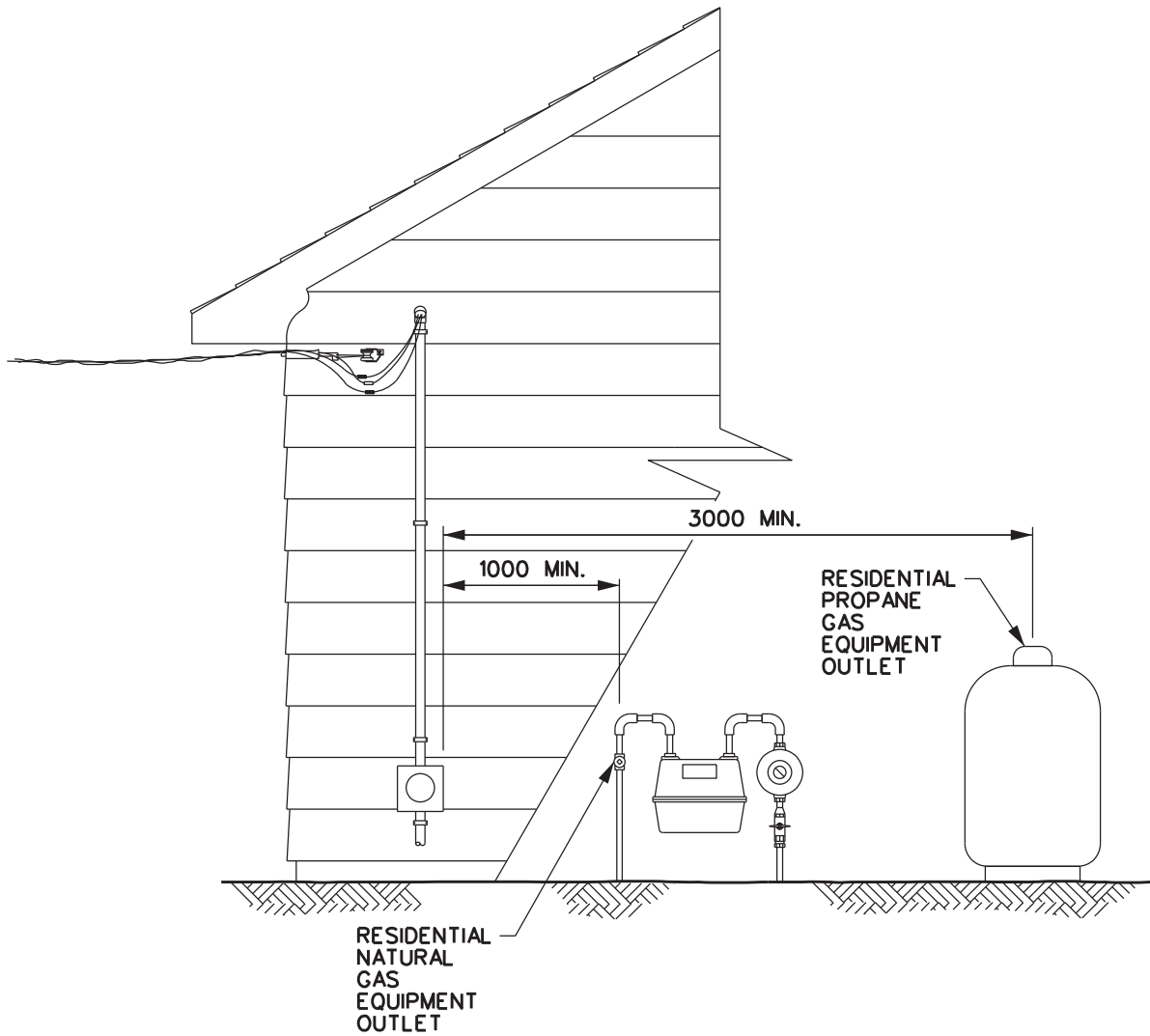

NOTES:

A. THESE CLEARANCES APPLY FROM ANY ELECTRICAL METERING EQUIPMENT TO ANY ABOVE GROUND NATURAL GAS EQUIPMENT OR RESIDENTIAL PROPANE EQUIPMENT.

B. ALL DIMENSIONS ARE IN MILLIMETERS UNLESS OTHERWISE SHOWN.

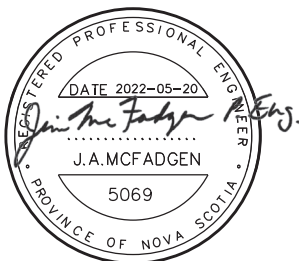

DISTRIBUTION STANDARDS



CLEARANCE TO ABOVE GROUND PROPANE OR NATURAL GAS EQUIPMENT

DATE:	2022-05-20	REV DATE:	
DRAWN:	M. HALASZ	STD NO:	V-ED-14M
APPROVED:		SHT NO:	2 OF 2

**NOVA SCOTIA POWER INC.
UTILITY SERVICE REQUIREMENTS**

**APPENDIX C
NPSI APPROVED CONNECTORS LISTING**

**NOVA SCOTIA POWER INC.
UTILITY SERVICE REQUIREMENTS**

Compression Terminals for Aluminum Cables

CABLE SIZE AWG/kcmil	Holes	3M	Blackburn	Burndy	Homac	Panduit	IlSCO	Penn-Union	Anderson	Stores Code
#4 Compact	1	-	ALS1	-	SA6-48	-	IACL-4	FKLA-W4-S	-	
#4 Compact	2	-	ALS2	YA4CA8DT	SA6-N	-	-	FKLA-W4-D	-	
#4 Compressed	1	-	ALS1	-	SA4-48	-	IACL-4	FKLA-W2-S	VAUL-4-12	
#4 Compressed	2	-	ALS2	YA4CA8DT	SA4-N	-	-	FKLA-W2-D	VAUL-4-12BN	
#3 Compact	1	-	-	-	-	-	-	-	-	
#3 Compact	2	-	-	YA4CA8DT	-	-	-	-	-	
#3 Compressed	1	-	-	-	-	-	-	FKLA-W2-S	-	
#3 Compressed	2	-	-	YA4CA8DT	-	-	-	FSLA-W2-D	-	
#2 Compact	1	40025	ALS3	-	SA3-48	-	IACL-2	FKLA-W2-S	VAUL-4-12	
#2 Compact	2	-	ALS4	YA2CA9	SA3-N	-	-	FSLA-W2-D	VAUL-4-12BN	
#2 Compressed	1	40025	ALS3	-	SA3-48	-	IACL-2	FKLA-C2-S	VAUL-1-12	
#2 Compressed	2	-	ALS4	YA2CA9	SA3-N	-	-	FSLA-C2-D	VAUL-1-12BN	
#1 Compact	1	40029	ALS3	-	SA3-48	-	-	FKLA-C2-S	VAUL-1-12	132890
#1 Compact	2	-	ALS4	YA2CA9	SA3-N	-	-	FSLA-C2-D	VAUL-1-12BN	
#1 Compressed	1	40029	ALS3	-	SA2-48	-	-	FSLA-R2-S	VAUL-1-12	
#1 Compressed	2	-	ALS4	YA2CA9	SA2-N	-	-	FSLA-R2-D	VAUL-1-12BN	144376
1/0 Compact	1	40033	-	YA25A9	SA386-48	LAA1/0-12-X	IACL-1/0	FSLA-R2-S	VAUL-1/0-12	
1/0 Compact	2	-	-	YA25A7	SA386-N	-	2IACL-1/0	FSLA-R2-D	VAUL-1/0-12BN	
1/0 Compressed	1	40033	ALS5	YA25A9	SA1/0-48	LAA1/0-12-X	IACL-1/0	FSLA-010-S	VAUL-1/0-12	120410
1/0 Compressed	2	-	ALS6	YA25A7	SA1/0-N	-	2IACL-1/0	FSLA-010-D	VAUL-1/0-12BN	151265
2/0 Compact	1	40037	ALS5	YA26A1	SA1/0-48	LAA2/0-12-5	IACL-2/0	FSLA-010-S	VAUL-1/0-12	
2/0 Compact	2	40137	ALS6	YA26A3	SA1/0-N	LAB2/0-12-5	2IACL-2/0	FSLA-010-D	VAUL-1/0-12BN	
2/0 Compressed	1	40037	ALS7	YA26A1	SA2/0-48	LAA2/0-12-5	IACL-2/0	FSLA-013-S	VAUL-2/0-12	
2/0 Compressed	2	40137	ALS8	YA26A3	SA2/0-N	LAB2/0-12-5	2IACL-2/0	FSLA-013-D	VAUL-2/0-12BN	
3/0 Compact	1	40041	ALS7	YA27A3	SA2/0-48	LAA3/0-12-5	IACL-3/0	FSLA-013-S	VAUL-2/0-12	
3/0 Compact	2	40141	ALS8	YA27A5	SA2/0-N	LAB3/0-12-5	2IACL-3/0	FSLA-013-D	VAUL-2/0-12BN	
3/0 Compressed	1	40041	ALS9	YA27A3	SA3/0-48	LAA3/0-12-5	IACL-3/0	FSLA-017-S	VAUL-3/0-12	155770
3/0 Compressed	2	40141	ALS10	YA27A5	SA3/0-N	LAB3/0-12-5	2IACL-3/0	FSLA-017-D	VAUL-3/0-12BN	140613
4/0 Compact	1	40045	ALS9	YA28A3	SA3/0-48	LAA4/0-12-5	IACL-4/0	FSLA-017-S	VAUL-3/0-12	
4/0 Compact	2	40145	ALS10	YA28A5	SA3/0-N	LAB4/0-12-5	2IACL-4/0	FSLA-017-D	VAUL-3/0-12BN	
4/0 Compressed	1	40045	ALS11	YA28A3	SA4/0-48	LAA4/0-12-5	IACL-4/0	FSLA-025-S	VAUL-4/0-12	120416
4/0 Compressed	2	40145	ALS12	YA28A5	SA4/0-N	LAB4/0-12-5	2IACL-4/0	FSLA-025-D	VAUL-4/0-12BN	146151
250 Compact	1	40049	ALS13	YA29A1	SA4/0-48	LAA250-12-5	IACL-250	FSLA-025-S	VAUL-4/0-12	
250 Compact	2	40149	ALS14	YA29A3	SA4/0-N	LAB250-12-5	2IACL-250	FSLA-025-D	VAUL-4/0-12BN	106629
250 Compressed	1	40049	ALS13	YA29A1	SA4/0-48	LAA250-12-5	IACL-250	-	VAUL-4/0-12	
250 Compressed	2	40149	ALS14	YA29A3	SA4/0-N	LAB250-12-5	2IACL-250	-	VAUL-4/0-12BN	
300 Compact	1	40053	ALS13	YA30A1	SA300-48	LAA300-12-2	IACL-300	FSLA-025-S	VAUL-4/0-12	
300 Compact	2	40153	ALS14	YA30A3	SA4/0-N	LAB300-12-2	2IACL-300	FSLA-025-D	VAUL-4/0-12BN	
300 Compressed	1	40053	ALS15	YA30A1	SA300-48	LAA300-12-2	IACL-300	FSLA-030-S	VAUL-300-12	
300 Compressed	2	40153	ALS16	YA30A3	SA300-N	LAB300-12-2	2IACL-300	FSLA-030-D	VAUL-300-12BN	
350 Compact	1	40056	ALS15	YA31A1	-	LAA350-12-2	IACL-350	FULA-030-S	VAUL-300-12	
350 Compact	2	40156	ALS16	YA31A3	SA300-N	LAB350-12-2	2IACL-350	FSLA-030-D	VAUL-300-12BN	
350 Compressed	1	40056	ALS17	YA31A1	SA350-48	LAA350-12-2	IACL-350	FULA-035-S	VAUL-350-12	132898
350 Compressed	2	40156	ALS18	YA31A3	SA350-N	LAB350-12-2	2IACL-350	FSLA-035-D	VAUL-350-12BN	-
400 Compact	1	-	ALS17	YA31A1	SA350-48	-	-	FULA-035-S	VAUL-350-12	
400 Compact	2	40160	ALS18	YA31A3	SA350-N	LAB400-12-2	-	FULA-035-D	VAUL-350-12BN	
400 Compressed	1	-	ALS19	YA31A1	SA400-48	-	-	FULA-R033-S	VAUL-400-12	
400 Compressed	2	40160	ALS20	YA31A3	SA400-N	LAB400-12-2	-	FULA-R033-D	VAUL-400-12BN	
500 Compact	1	-	ALS19	YA34A7	SA400-48	LAA500-12-2	IACL-500	FULA-R033-S	VAUL-400-12	140612
500 Compact	2	40166	ALS20	YA34A3	SA400-N	LAB500-12-2	2IACL-500	FULA-R033-D	VAUL-400-12BN	101127
500 Compressed	1	-	ALS23	YA34A7	CFA500-48	LAA500-12-2	IACL-500	FULA-050-S	VAUL-500-12	112030
500 Compressed	2	40166	ALS24	YA34A3	SAB500-N	LAB500-12-2	2IACL-500	FULA-050-D	VAUL-500-12BN	101127
600 Compact	1	-	ALS23	-	CFA500-48	-	IACL-600	-	VAUL-500-12	
600 Compact	2	40170	ALS24	YA36A3	SAB500-N	LAB600-12-2	2IACL-600	-	VAUL-500-12BN	
600 Compressed	1	-	-	-	-	-	IACL-600	-	-	
600 Compressed	2	40170	ALS32	YA36A3	-	LAB600-12-2	2IACL-600	-	VAUL-600-12BN	
750 Compact	1	-	-	40073	-	-	-	-	-	189253
750 Compact	2	40172	ALS32	YA39A5	-	LAB750-12-1	2IACL-750	-	VAUL-750-12BN	120418
750 Compressed	1	-	-	YA39A1	-	-	-	-	-	
750 Compressed	2	40172	ALS44	YA39A5	-	LAB750-12-1	2IACL-750	-	VAUL-750-12BN	120418
1000 Compact	1	-	-	-	-	-	-	-	-	
1000 Compact	2	-	-	YA44A3	-	-	2IACL-1000	-	-	
1000 Compressed	1	-	-	-	-	-	-	-	-	
1000 Compressed	2	-	ALS60	YA44A3	-	-	2IACL-1000	-	VAUL-1000-12BN	

DISTRIBUTION STANDARDS



Paul Hubley
NSP APPROVAL:

**APPROVED COMPRESSION TERMINALS
FOR ALUMINUM CABLES**

DATE:	2016-01-14	REV DATE:	2018-02-28
DRAWN:	PAUL HUBLEY	STD NO:	4U-11M
DESIGNED:	A. KOVALKO	SHT NO:	1 OF 1 (R1)

Compression Terminals for Copper Cables

CABLE SIZE AWG/kc	Holes	3M	Blackburn	Burndy	Homac	Panduit	IlSCO	Penn-Union	Anderson	Stores Code
#6	1	-	-	-	-	-	CLNS-6-12	-	-	-
#4	1	-	-	-	-	-	CLNS-4-12	-	-	-
#3	1	-	-	-	-	-	CLNS-3-12	-	-	-
#2	1	-	-	-	L2-48	-	CLNS-2-12	-	-	100397
#1	1	-	-	-	L1-48	LCC2-12-Q	CLNS-1-12	-	-	-
1/0	1	-	-	-	L1/0-48	-	CLNS-1/0-12	-	VHCL-1/0-12	-
1/0	2	31130	LCN10	YA252N	L1/0-N	LCC1/0-12-X	CLND-1/0-12-134	BBLU-1/0D3	VHCL-1/0-12BN	119250
2/0	1	-	-	YA26N	L2/0-48	LCB2/0-12-X	CLNS-2/0-12	BBLU-2/0S1	VHCL-2/0-12	119259
2/0	2	31137	LCN20	YA262N	L2/0-N	LCC2/0-12-X	CLND-2/0-12-134	BBLU-2/0D	VHCL-2/0-12BN	105331
3/0	1	31041	CTL30L-12	YA27	L3/0-48	LCB3/0-12-X	CLNS-3/0-12	BBLU-3/0S	VHCL-3/0-12	116422
3/0	2	31141	LCN30	YA272N	L3/0-N	LCC3/0-12-X	CLND-3/0-12-134	BBLU-3/0D	VHCL-3/0-12BN	156576
4/0	1	31045	CTL40L-12	YA28	L4/0-48	LCB4/0-12-X	CLNS-4/0-12	BBLU-4/0S	VHCL-4/0-12	116432
4/0	2	31145	LCN40	YA282N	L4/0-N	LCC4/0-12-X	CLND-4/0-12-134	BBLU-4/0D	VHCL-4/0-12BN	114931
250	1	31049	CTL250L-12	YA29	L250-48	LCB250-12-X	CLNS-250-12	BBLU-025S	VHCL-250-12	101126
250	2	31149	LCN250	YA292N	L250-N	LCC250-12-X	CLND-250-12-134	BBLU-025D	VHCL-250-12BN	116424
300	1	31053	CTL300L-12	YA30	L300-48	LCB300-12-X	CLNS-300-12	BBLU-030S	VHCL-300-12	-
300	2	31153	LCN300	YA302N	L300-N	LCC300-12-X	CLND-300-12-134	BBLU-030D	VHCL-300-12BN	155592
350	1	31056	CTL350L-12	YA31	L350-48	LCB350-12-X	CLNS-350-12	BBLU-035S	VHCL-350-12	105340
350	2	31156	LCN350	YA312N	L350-N	LCC350-12-X	CLND-350-12-134	BBLU-035D	VHCL-350-12BN	138892
400	1	31060	-	YA32N	L400-48	LCB400-12-6	CLNS-400-12	BBLU-040S1	VHCL-400-12	-
400	2	31160	LCN400	YA322N	L400-N	LCC400-12-6	CLND-400-12-134	BBLU-040D	VHCL-400-12BN	-
500	1	31066	-	YA34N	L500-48	LCB500-12-6	CLNS-500-12	BBLU-050S2	VHCL-500-12	155046
500	2	31166	LCN500	YA342N	L500-N	LCC500-12-6	CLND-500-12-134	BBLU-050D	VHCL-500-12BN	150907
600	1	31068	-	YA36N	L600-48	LCB600-12-6	CLNS-600-12	-	VHCL-600-12	114932
600	2	31168	LCN600	YA362N	L600-N	LCC600-12-6	CLND-600-12-134	BBLU-060D	VHCL-600-12BN	137438
750	1	-	-	-	-	-	-	-	-	-
750	2	31172	-	YAZ392NNT	L750-N	-	-	-	-	116425
1000	1	-	-	-	-	-	-	-	-	115593
1000	2	31178	-	YAZ442NNT	L1000-NT	-	-	-	-	-

DISTRIBUTION STANDARDS



Paul Hubley
NSD APPROVAL:

**APPROVED COMPRESSION TERMINALS
FOR COPPER CABLES**

DATE:	2016-01-14	REV DATE:	2018-02-28
DRAWN:	PAUL HUBLEY	STD NO:	4U-12M
DESIGNED:	A. KOVALKO	SHT NO:	1 OF 1 (R1)

**NOVA SCOTIA POWER INC.
UTILITY SERVICE REQUIREMENTS**

**APPENDIX D
NPSI APPROVED UNDERGROUND MATERIALS**

**NOVA SCOTIA POWER INC.
UTILITY SERVICE REQUIREMENTS**

**NOVA SCOTIA POWER INC.
UTILITY SERVICE REQUIREMENTS**

Approved Material and Hardware List

General Notes:

1. Only the specified manufacturers' material or hardware as listed will be accepted by NSPI.
2. The item numbers refer to the number shown inside a circle (or ellipse) on the drawings.

ITEM NO.	DESCRIPTION	MFG.CAT.NO.
C 1050	CONDUIT, RIGID PVC, 90° UTILITY BEND, 36" RADIUS, 3" DIAMETER, AS PER CSA C22.2 NO. 211.2 OR NO. 211.3	FRE 40-3039 SCEPTER NSL3-36
C 1051	CONDUIT, DB TYPE II, 90° LONG SWEEP BEND, 36" RADIUS, 3" DIAMETER, AS PER CSA C22.2 NO. 211.1 OR NO. 211.3	FRE 40-3030R36 SCEPTER 83-0405-0030
C 1052	CONDUIT, DB TYPE II, 45° LONG SWEEP BEND, 36" RADIUS, 3" DIAMETER, AS PER CSA C22.2 NO. 211.1 OR NO. 211.3	FRE 40-3032R36 SCEPTER 83-0401-0030
C 1053	CONDUIT, DB TYPE II, 10 FT. LENGTH, STRAIGHT, 3" DIAMETER, AS PER CSA C22.2 NO. 211.1 OR NO. 211.3	FER 40-3000 SCEPTER 34-030-21-100
C 1054	END BELL, FOR USE ON 3" DIAMETER CONDUIT	FRE 40-3018 SCEPTER EB-45
C 1058	COUPLING, PVC ADAPTER, FOR USE ON 3" DIAMETER UTILITY BENDS	SCEPTER 83-0357-0030
C 1059	CONDUIT, RIGID PVC, 90° BEND, 13" RADIUS, 3" DIA., AS PER CSA C22.2 NO. 211.2 OR NO. 211.3	SCEPTER EE4590
C 1060	CONDUIT, REIGID PVC, 90° UTILITY BEND, 36" RADIUS, 4" DIAMETER, AS PER CSA C22.2 NO. 211.2 OR NO. 211.3	FRE 40-4039 SCEPTER NSL4-36
C 1061	CONDUIT, DB TYPE II, 90° LONG SWEEP BEND, 36" RADIUS, 4" DIAMETER, AS PER CSA C22.2 NO. 211.1 OR NO. 211.3	FRE 40-4030R36 SCEPTER 83-0405-0040
C 1062	CONDUIT, DB TYPE II, 45° LONG SWEEP BEND, 36" RADIUS, 4" DIAMETER, AS PER CSA C22.2 NO. 211.1 OR NO. 211.3	FRE 40-4032R36 SCEPTER 83-0401-0040
C 1063	Conduit 4" (100 mm) – PVC DB Type II or FRE	FRE 40-4000 SCEPTER 83-040-21-100
C 1064	END BELL, FOR USE ON 4" DIAMETER CONDUIT	FRE 40-4018 SCEPTER EB-55
C 1065	CONDUIT – END CAP FOR USE ON 4" (100 MM) DIAMETER CONDUIT	SCEPTER CAP55
C 1066	CONDUIT – COUPLING PVC TO PVC, FOR USE ON 4" (100 MM) DB TYPE II CONDUIT	SCEPTER EC55
C 1067	CONDUIT – COUPLING FRE TO FRE, FOR USE ON 4" (100 MM) FRE CONDUIT	FRE 40-4010

**NOVA SCOTIA POWER INC.
UTILITY SERVICE REQUIREMENTS**

C 1068	CONDUIT - ADAPTOR COUPLING, RIGID PVC TO DB TYPE II, FOR USE ON 4" (100 MM) CONDUIT	SCEPTER 83-0357-0040
C 1072	CONDUIT, DB TYPE II, 10 FOOT LENGTH, STRAIGHT, 5" DIAMETER, AS PER CSA C22.2 NO. 211.1 OR NO. 211.3	FRE 40-5032R48 SCEPTER 83-0402-0050
C 1073	CONDUIT, DB TYPE II, 10 FOOT LENGTH, STRAIGHT, 5" DIAMETER, AS PER CSA C22.2 NO. 211.1 OR NO. 211.3	FRE 40-5000 SCEPTER 34-050-21-100
C 1075	END CAP, FOR USE ON 5" DIAMETER CONDUIT	SCEPTER CAP60
C 1077	COUPLING, FRE TO FRE, FOR USE ON 5" DIAMETER CONDUIT	FRE40-5010
C 59	GROUND ROD CONNECTOR – BRONZE, FOR NO. 20 (3/4) ROD AND #2/0 COPPER CONDUCTOR	ERICO/CPH34S BURNDY GRC3426 T&B JAB 34C
C 68	CONNECTOR – OKLIP, FOR COPPER TO COPPER CONNECTIONS (#1/0 STRD. TO #4/0 STRD.)	PENN UNION VT-2 BURNDY KVS-28 BLACKBURN 2B40 HUBBELL K3
C 94	COPPER WIRE - #2 AWG, BARE, 7 STRAND	Nexans 244160
C 95	COPPER WIRE - #2/0 AWG, BARE, 7 STRAND	Nexans 677294
E 1040	ENCLOSURE, ABOVE GRADE SERVICE, COMPLETE WITH HEX BOLTED TOP	PENCEL AG-20HD NORDIC PSP-151530-MG
E 1041	ENCLOSURE, ABOVE GRADE SERVICE, COMPLETE WITH HEX BOLTED TOP (SMALLER SIZE UNIT)	PENCEL AG-14HD NORDIC PSP-91330-MG
M 1000	MARKER TAPE – CAUTION, BURED ELECTRIC LINE – POLYETHYLENE, BLACK LETTERING ON RED BACKGROUND, 150 MM (6") WIDTH	ALLEN SYSTEMS #0761315 PANDUIT HTU-6Y-E T & B NA-0708
N 1000	NYLON FISH LINE – POLYETHYLENE BRAIDED TWINE, 4 MM DIAMETER	IMP GROUP LTD. COMPUTER #07-0044
R 12	GROUND ROD – STEEL, 20 X 3000 (3/4" X 10'), WITH TOP 250 MM (10") GALVANIZED	SLACAN 9340 HUBBELL 8620
R 11	ROD, GROUND, STEEL, WITH TOP 250mm GALVANIZED, AS PER CSA STD. C83.41M, ROD NO. 20 X 1800	HYDEL 3410G SLACAN 9340