

Vehicle Practice

Reference:	Revision:
VP 04 12	2.1
Page:	1 of 2
Date:	1986 12 22
Revised:	2000 12 14

BONDING LUGS FOR AERIAL DEVICES AND BUCKET EQUIPPED DERRICKS

Practice:

INTRODUCTION

Standard Work Methods “Temporary Grounding of Overhead Distribution Lines” (SWM 3:01) and “Temporary Grounding of Overhead Transmission Lines” (SWM 3:02) require the installation of a bonding lug or stirrup in the vicinity of the upper work station on all aerial device (Class 4) and derrick equipped trucks or off-road vehicles.

INSTRUCTIONS FOR BONDING LUG OR STIRRUP INSTALLATIONS

1. A ½” x 3” long cadmium or galvanized plated capscrew is to be located on the aerial device models as shown in the sketches. Tack weld the hexagon nut to the bolt head (Fig. 1) or alternate location shown (Fig. 2). Screw the capscrew into the nut until it bottoms out.
2. Derrick trucks with slide-out glass booms were originally equipped with a steel handle (ref. Fig. 4). This handle can serve as a grounding stirrup. If handle is missing or damaged, it is to be repaired or replaced.
3. Older model King derricks equipped with a pin-on type jib boom will be fitted with a cap screw and nut as shown in Figure 3.
4. Models not identified in the figures are to have lugs or stirrups located in an accessible location similar to the given examples.
5. All installations are to be checked to ensure hooking of hoses or interference does not occur.

Note: DO NOT WELD TO LANYARD CONNECTION ASSEMBLY

Reference:	Revision:
VP 04 12	2.1
Page:	2 of 2
Date:	1986 12 22
Revised:	2000 12 14

BONDING LUGS FOR AERIAL DEVICES AND BUCKET EQUIPPED DERRICKS

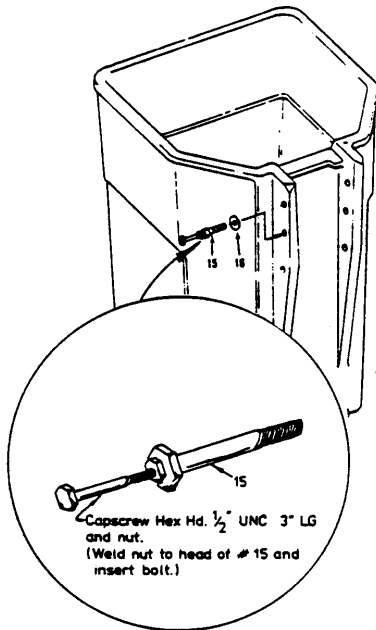

Figure 1 Pitman type buckets

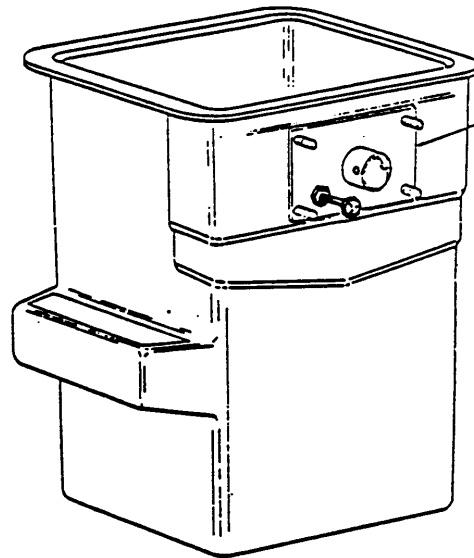

Figure 2
Holan type buckets

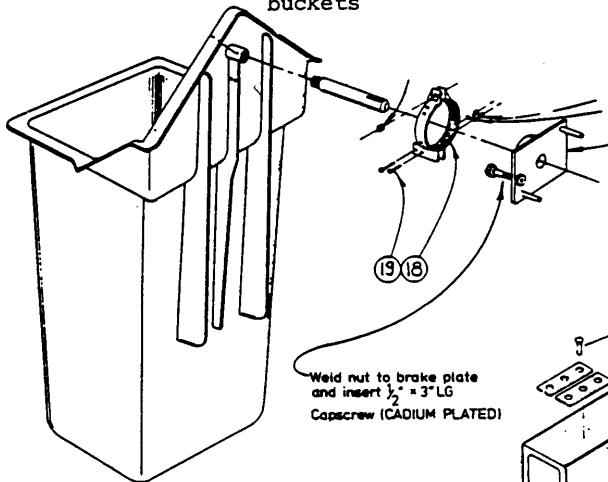

Figure 3
King jib boom type buckets

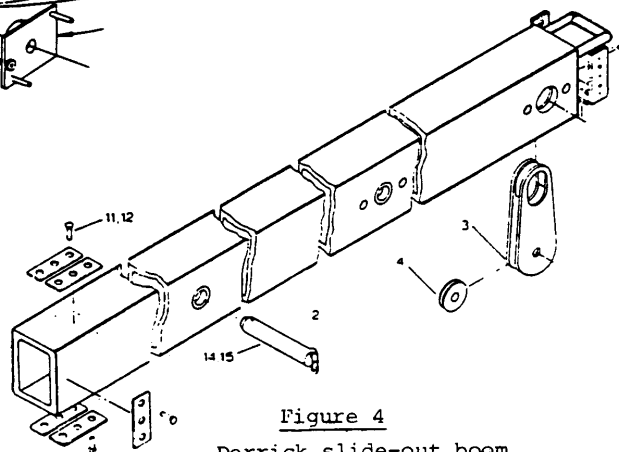

Figure 4
Derrick slide-out boom with handle