

# Vehicle Practice

Reference:	Revision:
VP 07 04	0
Page:	1 of 3
Date:	1986 12 22
Revised:	

## EQUIPMENT LOADING PRACTICES

Practice:

### 1.0 INTRODUCTION

When employees load or unload wheeled or crawler equipment to or from trailers or floats the following practices shall be followed.

### 2.0 PERSONNEL

- 2.1 It is the responsibility of management to assign employees to loading operations and to ensure that assigned employees are competent and that they understand and follow these practices.
- 2.2 The assigned employee or contractor shall remain in visual and voice communication with the equipment operator at all times during loading and unloading operations.
- 2.3 The Supervisor is to provide the driver of the truck, trailer or float with the weights, dimensions of the equipment being loaded, and advise or arrange for special permits when required.
- 2.4 The location of and the securing of the load and the overall dimensions and weight of the loaded truck, trailer or float shall be the responsibility of the driver of the truck.
- 2.5 An employee shall not work alone while loading or unloading crawler or wheel type equipment from a truck, trailer or float unless accompanied by a contractor or second individual.

### 3.0 EQUIPMENT

- 3.1 The assigned employee shall ensure that the truck, trailer or float is adequately secured against movement from the loading or unloading forces. This will require applying the vehicle service brakes and chocks and the use of blocking if necessary.

Prepared by: D. West

Approved by: J.F. Baird

*Fleet Services*



Reference: VP 07 04	Revision: 0	<b>EQUIPMENT LOADING PRACTICES</b>
Page: 2 of 3		
Date: 1986 12 22		
Revised:		

- 3.2 When floats equipped with removable goose-necks are loaded or unloaded, the goose-neck shall be removed and the equipment loaded or unloaded from the front of the float. Figure 2.
- 3.3 If a tilt and load type trailer is to be loaded or unloaded with crawler or wheel type equipment, the load deck shall be positioned on the ground.
- 3.4 When loading digger derrick equipped muskeg tractors on platform trailers blocking, shown in Figure 1, shall be used to decrease the loading angle.
- 3.5 Where the float is not equipped with a removable goose-neck, it is mandatory that a suitable loading ramp or blocking be used.
- 3.6 All planks, timbers and blocking used to construct temporary loading ramps shall be in good condition.
- 3.7 Loading over the side is not permitted under any circumstance.
- 3.8 The load deck of the trailer or float shall be level when equipment is being loaded or unloaded.
- 3.9 The load deck shall be clean and provide adequate traction for the equipment being loaded or unloaded.
- 3.10 When a trailer or float is equipped with self-storing loading ramps and ramp support jacks, the support jacks and loading ramps shall be in place when loading or unloading.
- 3.11 When loading or unloading trailers of the tagalong type, they shall be connected to their towing vehicle.

Reference: VP 07 04	Revision: 0
Page: 3 of 3	
Date: 1986 12 22	
Revised:	

## EQUIPMENT LOADING PRACTICES

### TRAILER SET UP TO LOAD A MUSKEG DIGGER

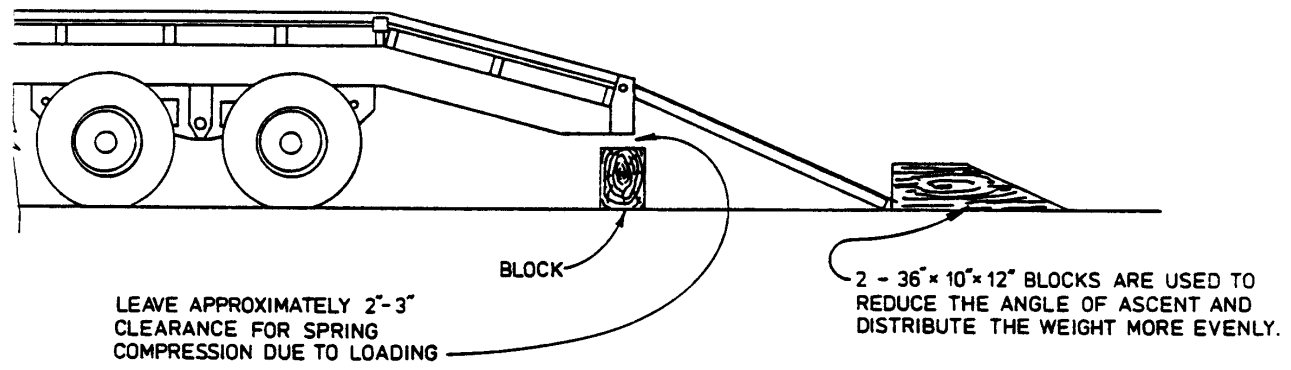

FIGURE 1

### HYDRAULIC DETACHABLE GOOSENECK

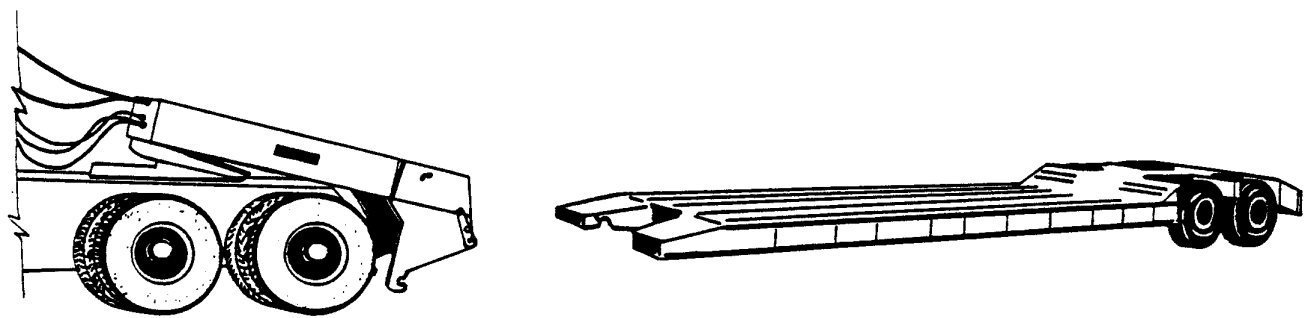

FIGURE 2