

Vehicle Practice

Reference:	Revision:
VP 09 24	2.1
Page: 1 of 6	
Date:	
Revised: 1995 06 14	

AIR SPRING BRAKE RETAINING CAGE AND BRAKE CHAMBER DISPOSER

Practice:

INTRODUCTION

This practice outlines safe working procedures for removal and disposal of damaged spring brake assemblies.

GENERAL

We have been advised by the Nova Scotia Registry of Motor Vehicles "Inspection Division" of the potential failure of the Aluminum End-Cup on Air Spring Brake Assemblies.

A person close to one of these units could receive injuries in time of failure.

The failure of units occur due to corrosion on the inside of the End-Cap Figure 1, item (3) causing the cap to weaken, resulting in an outward explosion of the coiled spring Figure 1, item (2).

This spring provides 3000 lbs. of thrust to the brake unit to which it is connected. This is to stop the vehicle in a situation when there is a loss of air, or to act upon the rear wheels as a parking brake.

The use of a Spring Chamber Retaining Cage (Safety Cage), Figure 2, will be mandatory when repairing or replacing damaged or defective Spring Brake Assemblies.

The use of a Spring Chamber Disposer, Figure 3, will also be mandatory. This device must be used to disarm damaged spring brake assemblies prior to disposal.

SERVICE PROCEDURES

Visually Check: End Cap, Clamp Assemblies and the Chamber Housing for damages/or corrosion.

- Check ventholes for signs of corrosion or dirt build up (indicating potential problem).
- Check End Cap for missing or damaged plastic Plug Item 8 – Replace damaged Plug and secure with a tie-strap to one of the Clamp Bolts Item 9.

Prepared by: D. West

Approved by: J. Abraham

Fleet Services



Reference: VP 09 24	Revision: 2.1
Page: 2 of 6	
Date:	
Revised: 1995 06 14	

AIR SPRING BRAKE RETAINING CAGE AND BRAKE CHAMBER DISPOSER

- If, after the visual inspection, there is any question on the integrity of the End Cap, Clamp Assembly or the Chamber Housing, DO NOT Service before first installing the Safety Cage over the Brake Assembly.

OLD STYLE

Spring and Service Brake Champer Assembly Figure 1

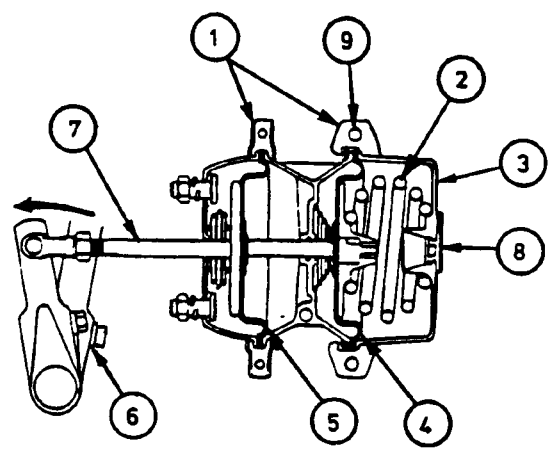

Items

1. Clamp Assembly
2. Coiler Spring
3. End Cap
4. Spring Chamber Diaphragm
5. Service Brake Diaphragm
6. Slack Adjusted
7. Push Rod
8. Plastic Plug
9. Clamp Bolt

NEW STYLE

Sealed, Double Diaphragm Spring Brake

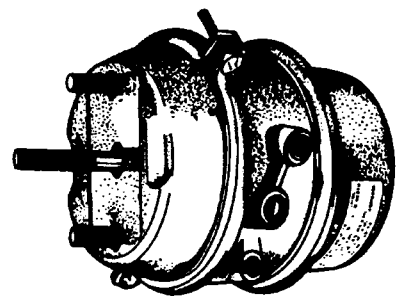

Reference: VP 09 24	Revision: 2.1	AIR SPRING BRAKE RETAINING CAGE AND BRAKE CHAMBER DISPOSER
Page: 3 of 6		
Date: Revised: 1995 06 14		

PRACTICE

- Block wheels (front and back).
- Using caging bolt, unload coil spring.
- Deplete the air from the Brake System.
- Carefully slip the Safety Cage Figure 2 over the defective Spring Chamber. Secure Cage to the Chamber with Cage Retaining Pin.
- Disconnect air lines (and tag lines).
- Loosen and remove Brake Chamber Retaining Nuts and Lock Washers.
- **Carefully** remove the Brake Assembly from the Axle for either repair or disposal.
- **CAUTION:** HANDLE WITH CARE – DO NOT DROP OR HAMMER.

Safety Cage - Figure 2

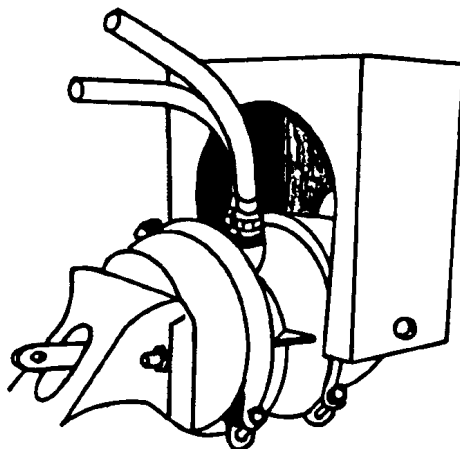

Reference: VP 09 24	Revision: 2.1	AIR SPRING BRAKE RETAINING CAGE AND BRAKE CHAMBER DISPOSER
Page: 4 of 6		
Date: Revised: 1995 06 14		

Disposal of Spring Chamber

- **Carefully** remove Safety Cage and place Brake Assembly through the open hatch into the Disposer Cage, Figure 3.
- Position the two bolts of the spring Brake Clamp Assembly so that they are visible through the slots on either side of the Disposer.
- Close the hatch and lock with Dead Bolt.
- Torch off the bolts and Clamp Assembly through the slot opening on old style chamber. The new style with no Clamps - cut holes in the side and torch the spring.
- **Be Aware:** The Spring will expand suddenly and with great force inside the Disposer.

Spring Chamber Disposer: Fabrication Specifications

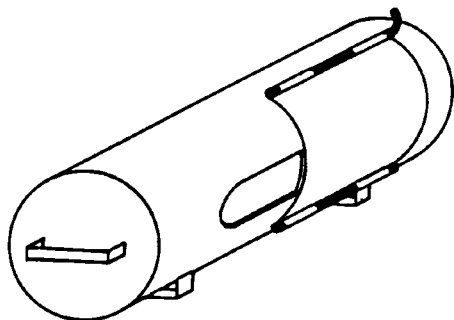

Disposer - Figure 3

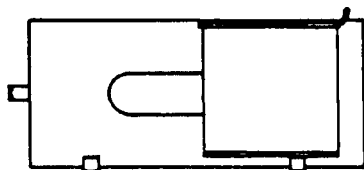

Figure 4

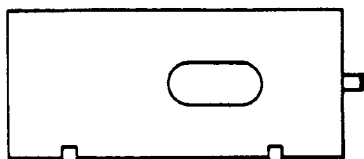

Figure 5

Materials

1. One 10" x 1/2" wall pipe 24" long. Two end caps 10" diameter cut from 1/2" steel plate hatch and dead-lock bolt hinges are cut from 1/2" thick wall tubing, bolt - 1/2" steel rod.
2. Cut 10" x 10" opening and weld end caps. Use the cut-out piece to fabricate hatch door, Figure 4.
3. Cut two 3" x 7" slots in the front and the back side of disposer to allow torching of the brake-chamber clamp assemblies, Figure 5. Weld one handle to one end and leg brackets to the bottom the disposer.
4. Door in closed position and dead lock bolt in place and secured.

cap
hatch
slot

Reference: VP 09 24	Revision: 2.1
Page: 5 of 6	
Date:	
Revised: 1995 06 14	

AIR SPRING BRAKE RETAINING CAGE AND BRAKE CHAMBER DISPOSER

SAFETY CAGE

Materials

- Two 8" x 9" x 1/4" Steel Plates
- Two 9" x 9" x 1/4" Steel Plates
- One 7 3/4" x 3 3/4" x 1/4" Plate
- One 5/8" x 9" Long Pin
- One 1/16" Hitch Pin

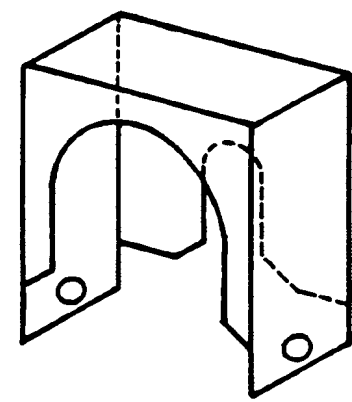

Fabrication Specification: 7" Cage

Fabrication Tolerance = 1/32 Inch

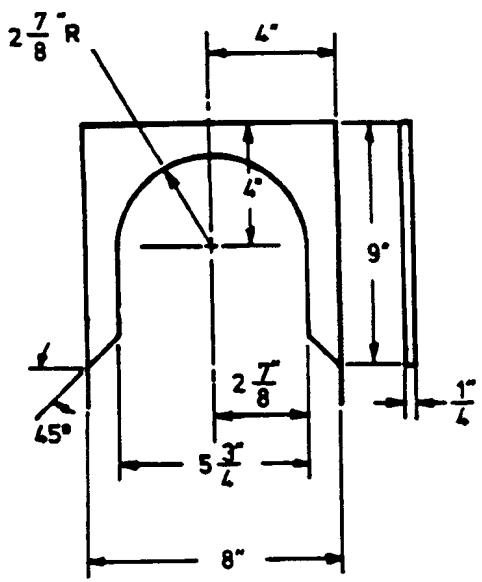

Rear Plate

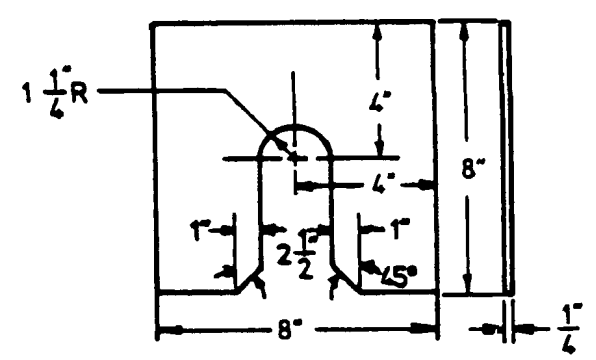

**Front Plate
1/4" Steel**

Reference: VP 09 24	Revision: 2.1
Page: 6 of 6	
Date:	
Revised: 1995 06 14	

AIR SPRING BRAKE RETAINING CAGE AND BRAKE CHAMBER DISPOSER

SAFETY CAGE

Materials

- Two 9" x 3 3/4" x 1/4" Steel Plate
- Two 10 1/2" x 4 3/4" x 1/4" Steel
- One 8 3/4" x 4 3/4" x 1/4" Steel
- One 5/8" x 10" Long Pin
- One 1/16" Hitch Pin

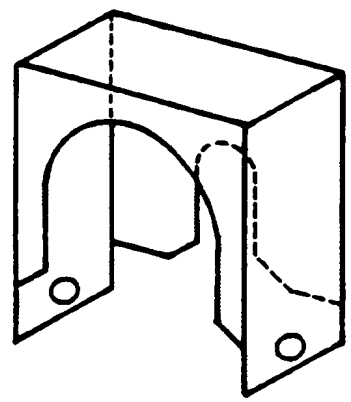

Fabrication Specification: 8" Cage

Fabrication Tolerance = 1/32 Inch

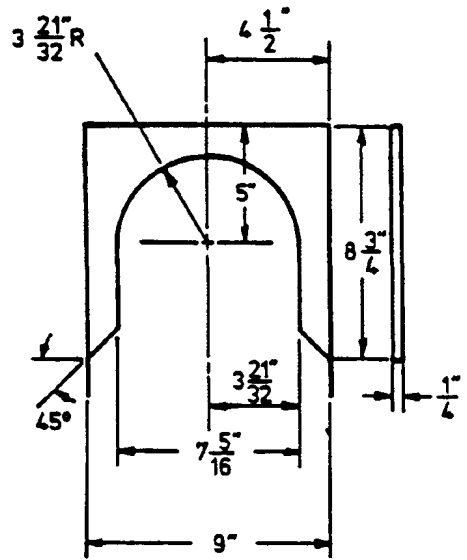
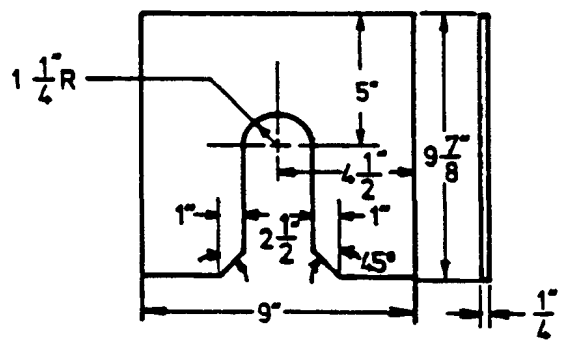

Rear Plate